

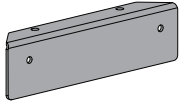

OMIX-ADA, Inc.

Part #11615.20
11615.21

XHD Corner Guards, 07-17 JK



Licence Plate Bracket (1)

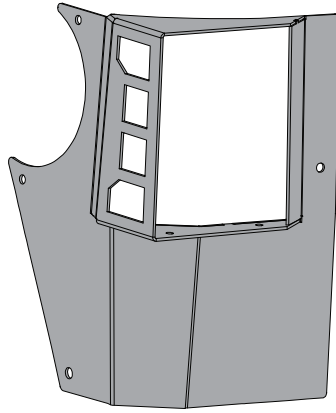

Left Corner Guard (1)

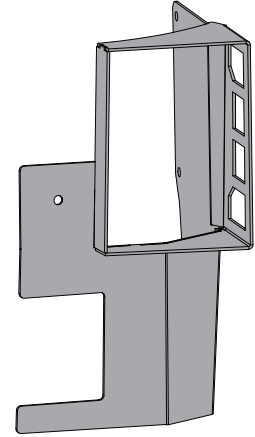

Right Corner Guard (1)

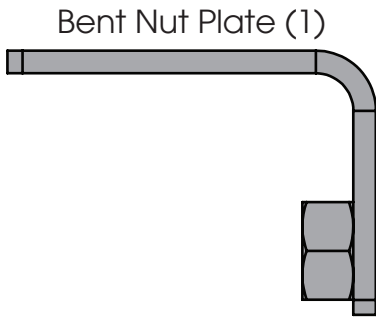

Bent Nut Plate (1)

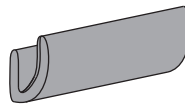

C-Style Trim (1)



M6 Washer (4)

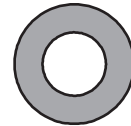

M8 Washer (8)



Long Nut Plate (3)

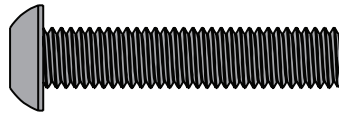

Long M8 Bolt (1)

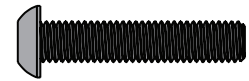

M6 Bolt (2)

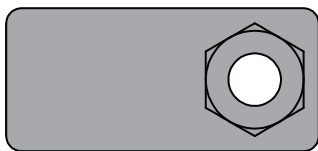

Nut Plate (3)

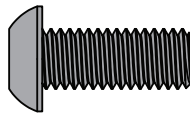

M8 Bolt (7)



M8 Hex Nut (1)



M6 Hex Nut (2)



XHD Corner Guards, 07-17 JK

1. Remove taillights and license plate housing from vehicle.

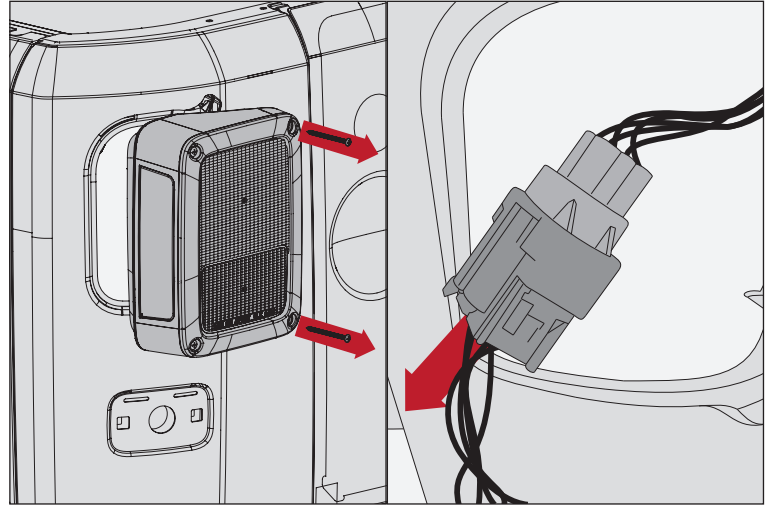

2. With a second person, align Left Corner Guard using fuel filler neck and body lines as a guide.

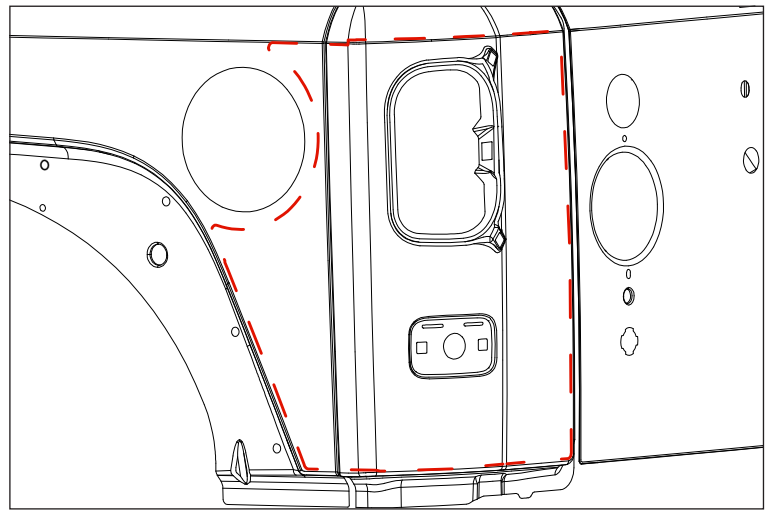

3. Mark four holes. Set Left Corner Guard aside.

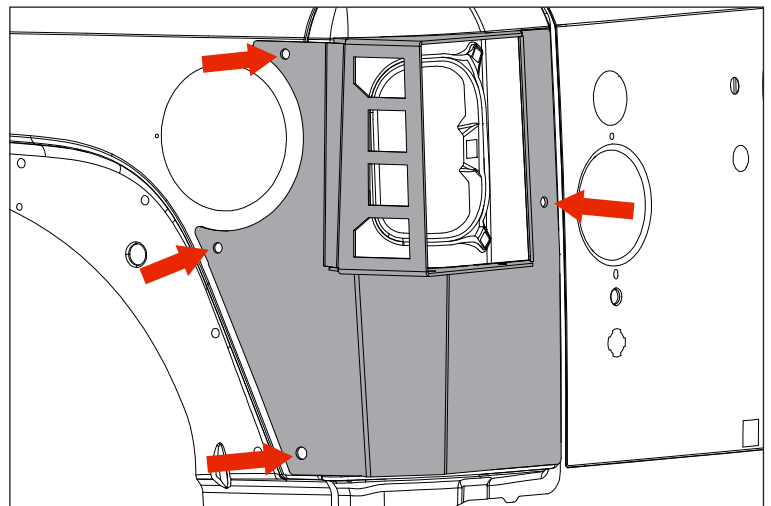

XHD Corner Guards, 07-17 JK

4. Using 1/8" drill, make a pilot hole at marked locations. Using a step bit, open hole to 3/8".

⚠ WARNING

Thin sheet metal can cause standard drill bits to grab. This could cause injury or damage to vehicle.

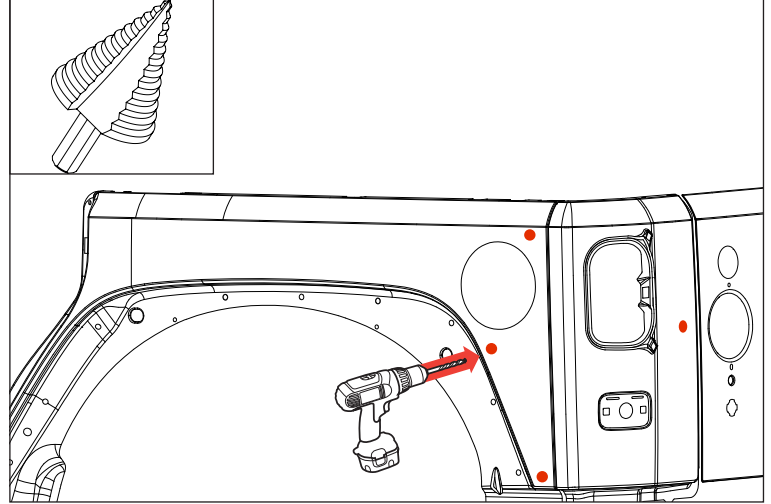

5. Slide C-style Trim onto Left Corner Guard as shown.

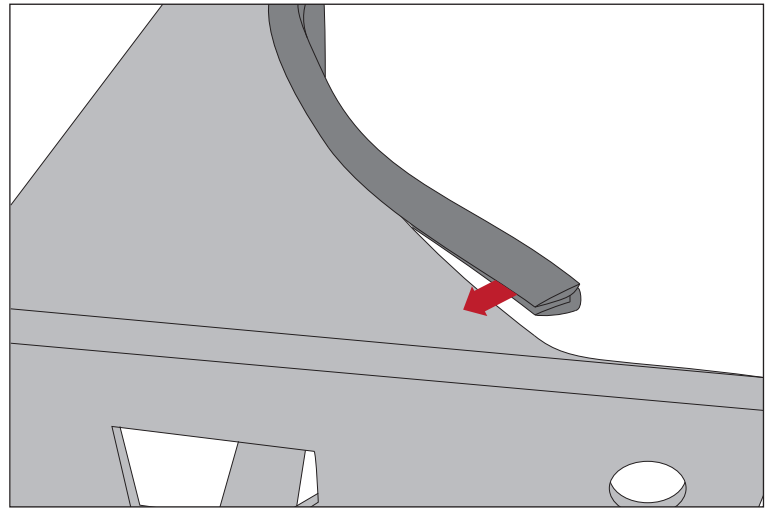

6. Align Left Corner Guard with vehicle using previously drilled holes, fuel filler neck, and body line.

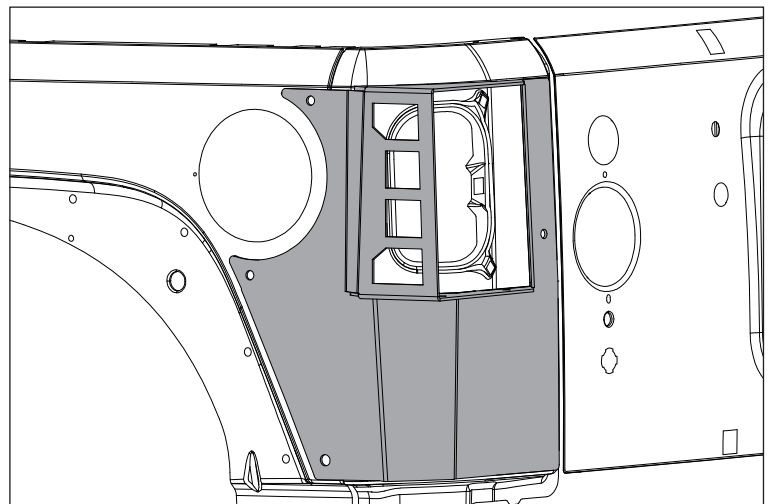



OMIX-ADA, Inc.

XHD Corner Guards, 07-17 JK

7. Attach Left Corner Guard to vehicle using supplied Nut Plate, Long M8 Bolt, M8 Nut, and M8 Washer.

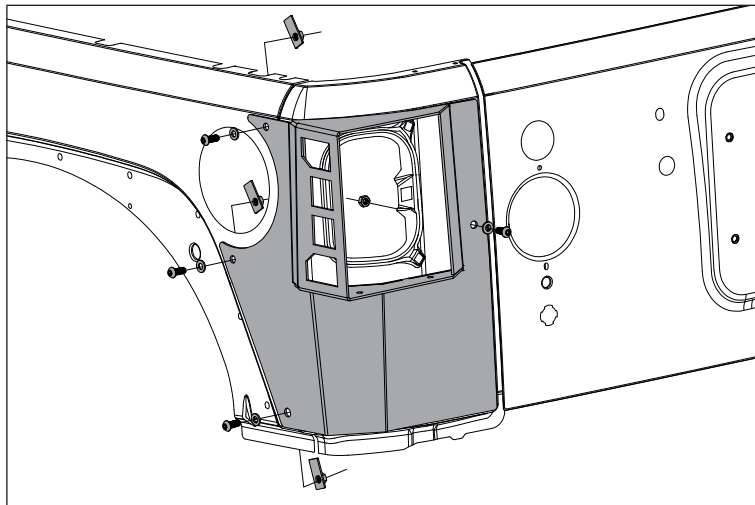

8. Repeat steps 2-6 for right side.

9. Attach Right Corner Guard to vehicle using M8 Bolt, M8 Washer, Long Nut Plate, and Bent Nut Plate.

10. Reattach taillights.

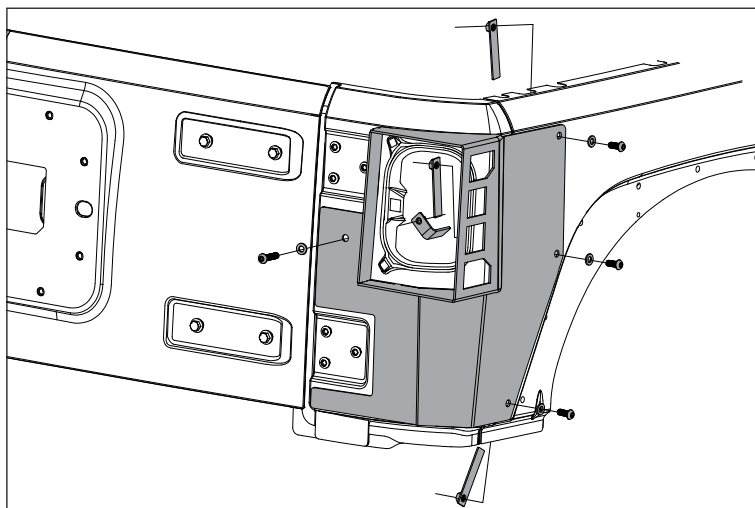

NOTICE It is recommended to use Rugged Ridge LED License Plate Bolts (#11233.10) to replace the OE License Plate Light.

11. Using supplied M6 hardware, attach License Plate Bracket to Left Corner Guard.

NOTICE A small hole can be drilled in Left Corner Guard just behind Licence Plate Bracket for license plate light wires.

