

## Offroad Jack Mounting Bracket, JT

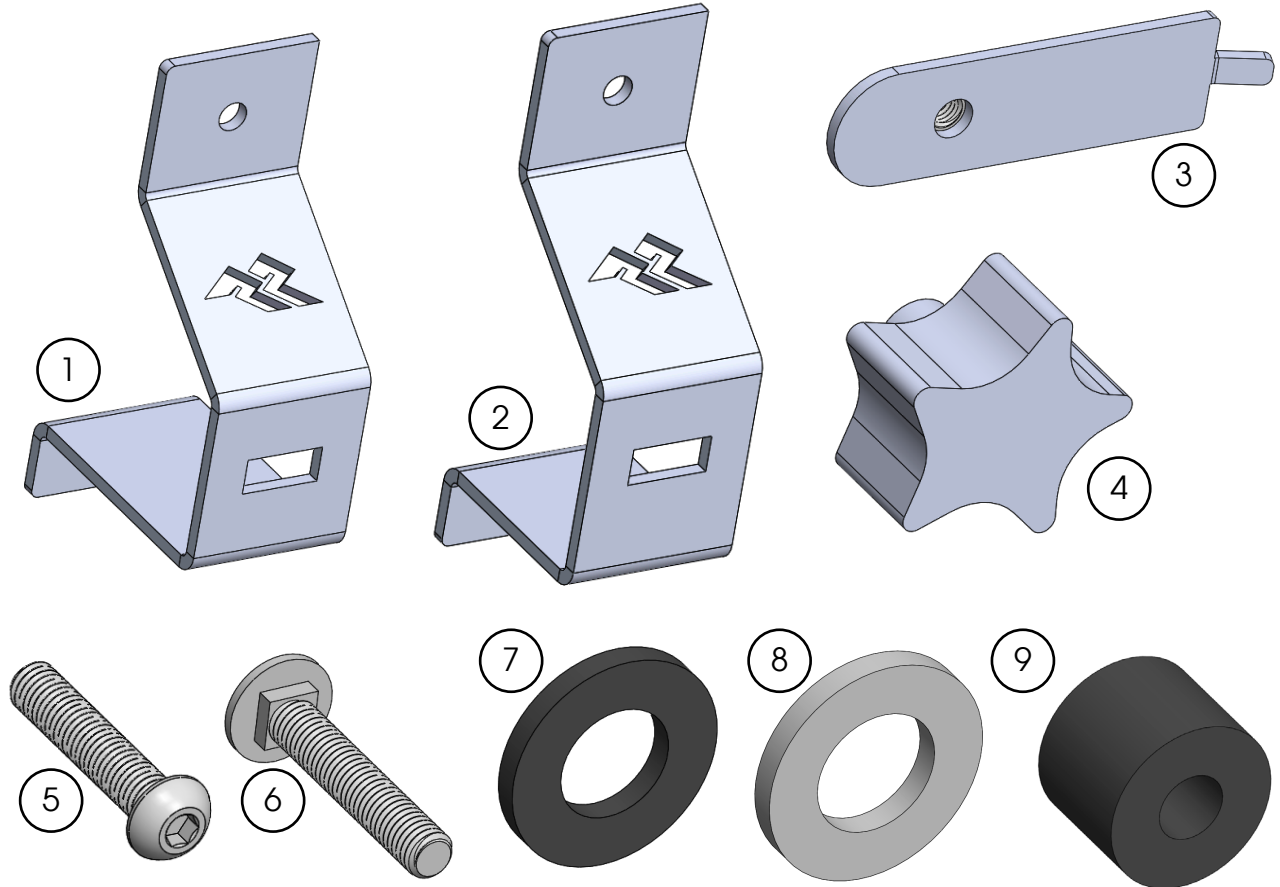

### Components

1. Mount, Rear (near tailgate).....	(1)	6. M10-1.5 x 45mm Carriage Bolt.....	(2)
2. Mount, Front (over wheelwell).....	(1)	7. M10 Washer .....	(2)
3. M8 Nut Plate .....	(2)	8. M8 Washer .....	(2)
4. Hand Knob (threaded) .....	(2)	9. Rubber Isolator .....	(2)
5. M8-1.25 x 30mm Allen Head Bolt.....	(2)		

## Offroad Jack Mounting Bracket, JT

1. To use the mounts it may require adjusting the jack mechanism up from the lowest position. This will allow the rear mount to support the jack near the jack foot plate.

Begin by sliding the nut plates into your JT track system. It may require inserting the nut plate at the front of the track and slide it to the desired position.

With both nut plates installed, thread the M8 Allen head bolt and washer through the bracket into the nut plate. Position the mounts to the desired area using the off-road jack as reference.

**NOTE:** To determine front and rear mounts, the rear mount has a wider spread from the body.

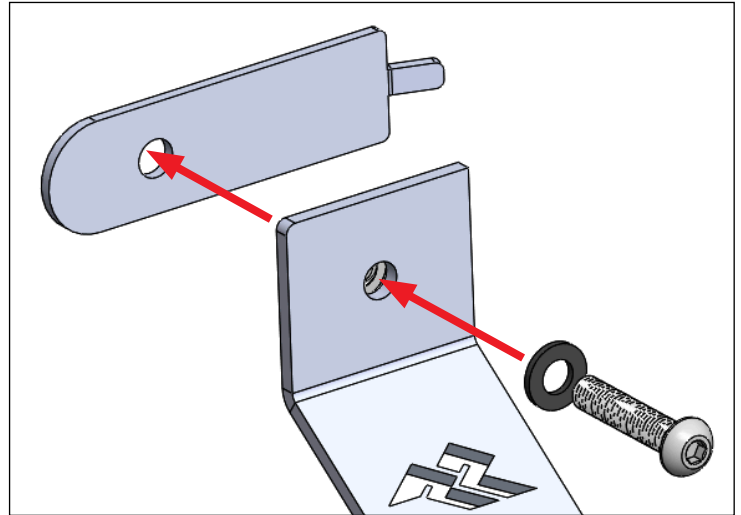

2. Place a M10 carriage bolt through each bracket. Then place the rubber isolator over the carriage bolt threads. Now position your off-road jack over the carriage bolt then install the M10 washer and thread the hand knob to the carriage bolt.

Adjust mounts on the track to not bind to the body, assuring the mounts are flat against the body and track bar. Fully tighten the Allen bolt and snug the hand knob.

