



## HD Hinge Casting PATENT PENDING

### CONTENTS:

HD Hinge Casting  
Spacer Plates (2 PCS)

### HARDWARE:

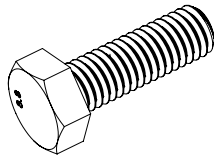

Hex Bolt X 4



Washer X 4

### TOOLS REQUIRED:

Socket Wrench  
10" extension  
13mm socket  
3/4" deep socket  
T-20, T-50 Torx bits  
Red Thread Lock  
Shims  
Torque Wrench

Spacer  
Plates

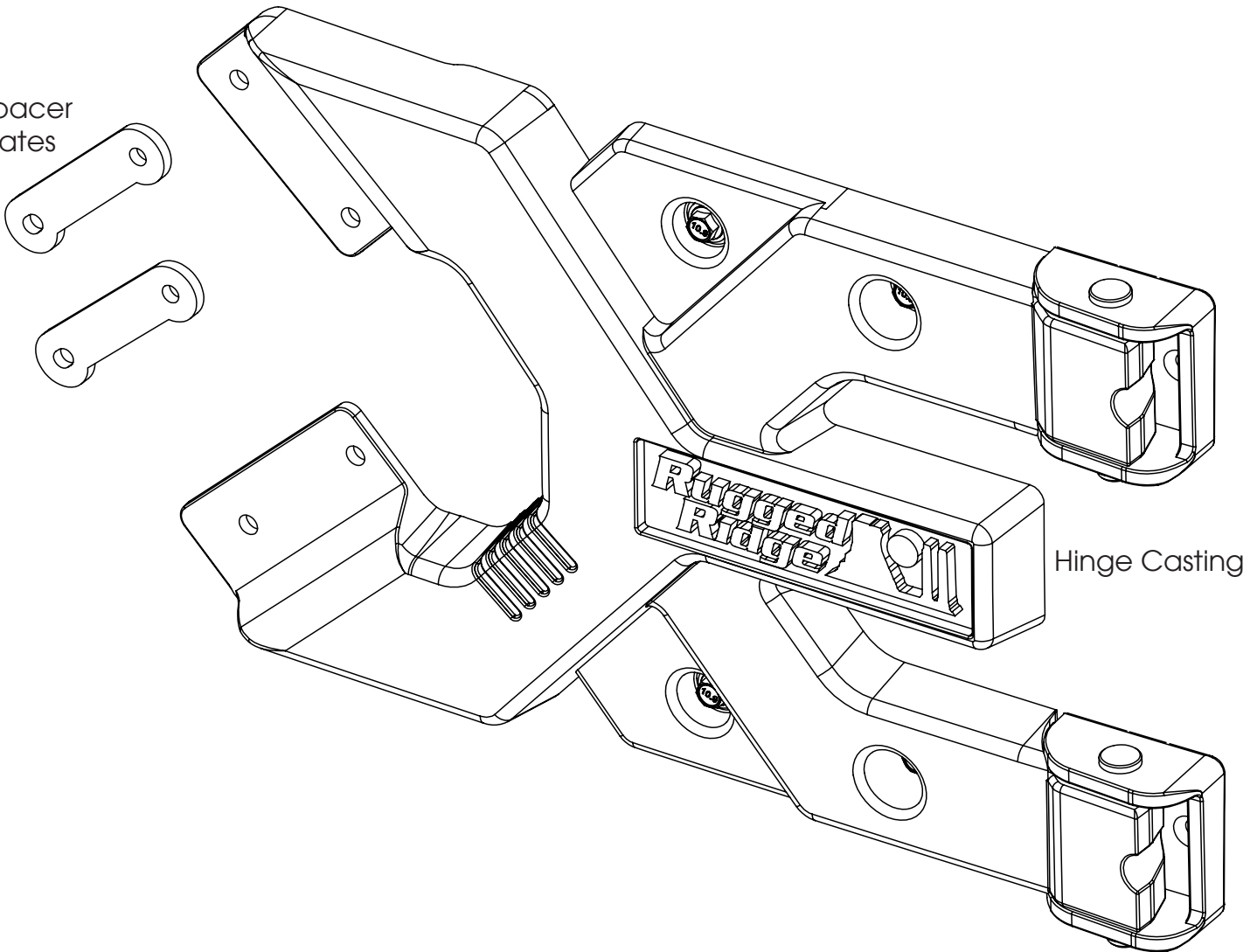

Hinge Casting



## HD Hinge Casting PATENT PENDING

### Important Safety Information

Your Rugged Ridge® Tire Carrier is intended to increase the utility and enjoyment of your Jeep® by providing easy access to your rear cargo area and secure mounting of your off-road spare tire. Before installation, please take a moment to review the following safety information and installation instructions. Important safety information is generally preceded by one of three signal words indicating the relative risk of injury. The signal words mean:

#### **WARNING**

A hazardous situation which, if not avoided, could result in serious injury or death. **You can be killed or seriously hurt if you do not follow instructions.**

#### **CAUTION**

A hazardous situation which, if not avoided, could result in minor or moderate injury. **You can be moderately hurt and may also suffer property damage if you do not follow instructions.**

#### **NOTICE**

Careful attention is required to this instruction or operation, but does not generally relate to personal injury. Damage to your product or other property may result if you do not follow instructions.

### Installation Instructions

To reduce risk of personal injury during assembly and use of this product:

- Wear gloves and safety glasses during installation.
- Tire Carrier and spare tire/wheel are heavy. Use jack or seek assistance when lifting, fastening parts, or installing wheel/tire to carrier.
- Tire Carrier is subject to vibration and shock loads from on and off road use. Regularly inspect carrier and lug nuts fastening spare to carrier. Do not use and repair if damaged. Use thread locker and keep lug nuts torqued to 80 ft./lbs.

## HD Hinge Casting PATENT PENDING

1. Take off spare tire by removing the 3 lug nuts using a 3/4" deep socket.

**CAUTION** Have another person help lift the tire off of the carrier.

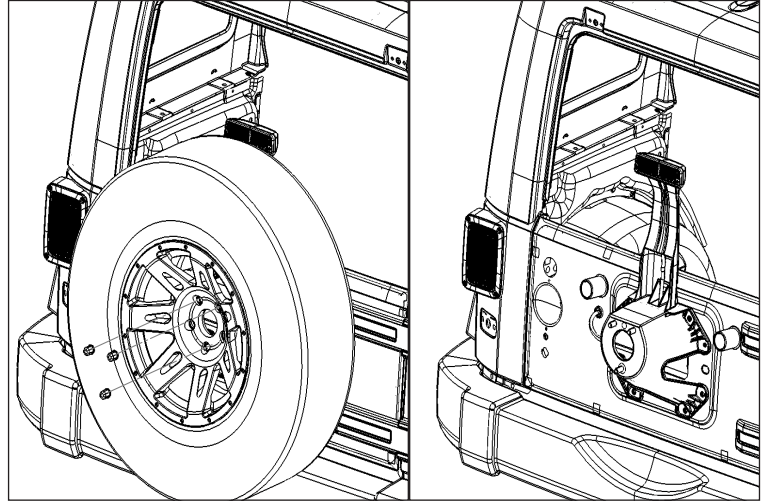

2. Open the tailgate. Using a T-20 Torx bit, remove 4 torx head screws that attach light to factory tire mount. Pull light away from tire mount.

3. Remove connector by pushing down on tab and pulling. Set light aside, it will be used later during installation. Place connector and wires off to side to not interfere with Tire Carrier installation.

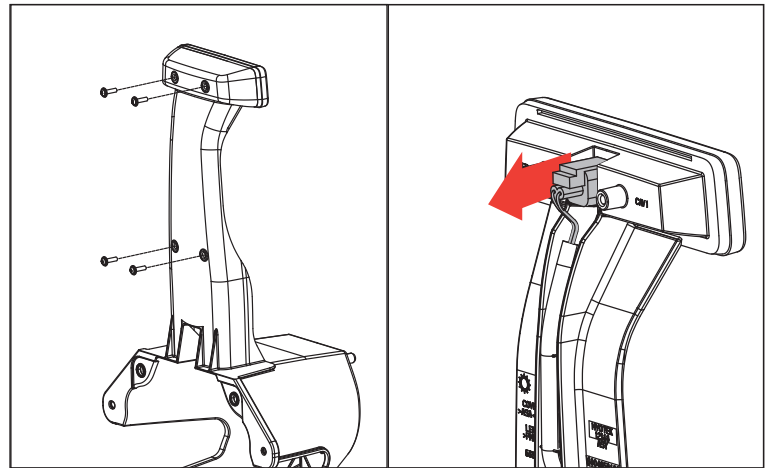

4. Twist and pull rubber bumper to remove from right side of tailgate only.

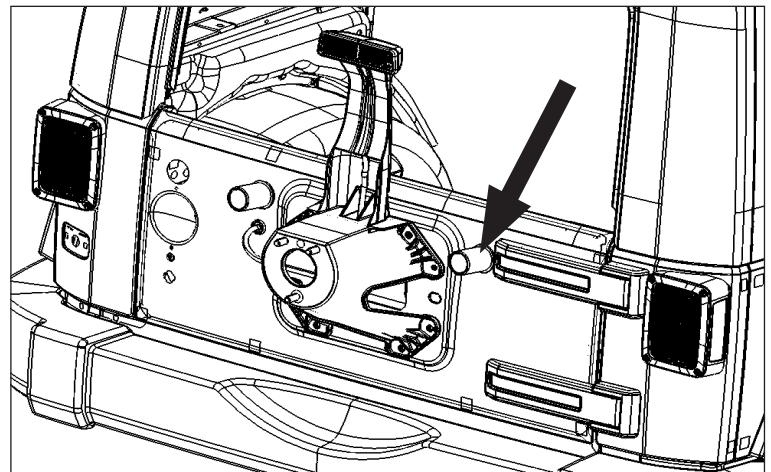

## HD Hinge Casting PATENT PENDING

5. Remove plastic hinge covers. For the long hinge covers, pull away from the vehicle and to the left.

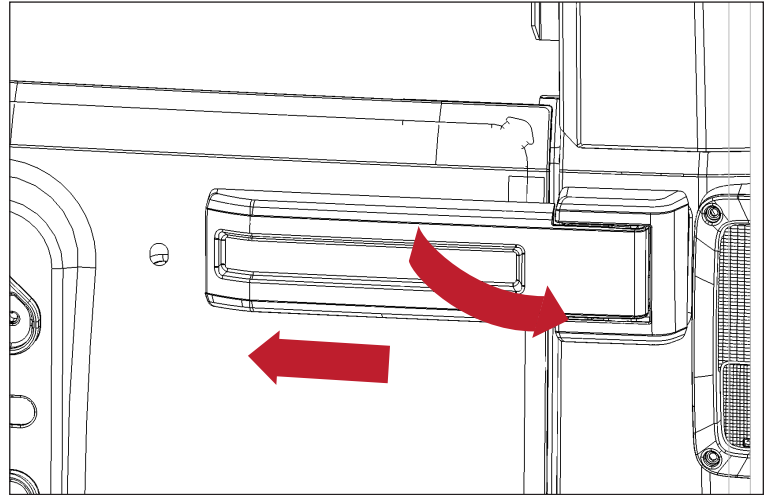

6. Remove plastic clips by pulling lower portion down and away from vehicle.

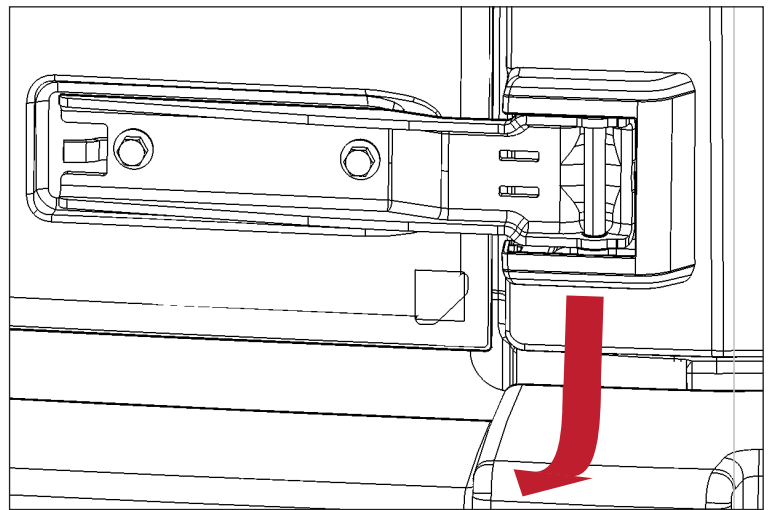

7. Remove the stock tire carrier and brake light holder by removing the 8 bolts indicated using a 13mm socket.

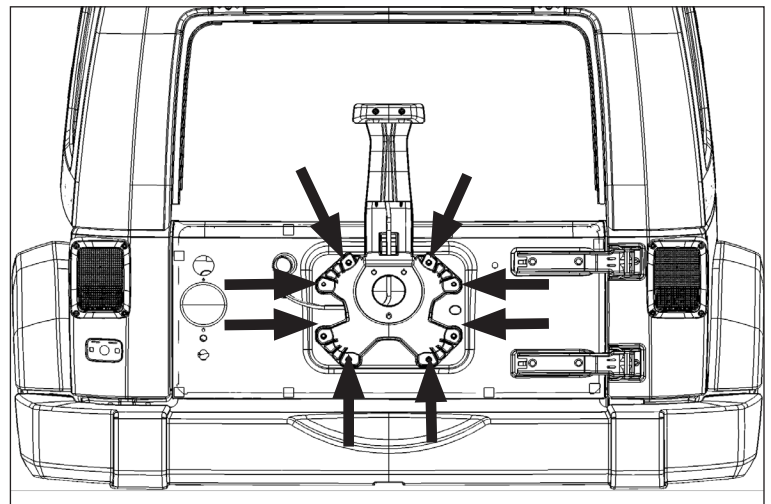



## HD Hinge Casting PATENT PENDING

8. Ensure tailgate is fully closed and locked. On both sides of tailgate, place shims between bumper and tailgate to hold tailgate in position while removing stock hinges.

Shims can be blocks of wood, wedged shims, etc. that can be made to fit snugly and securely between bumper and tailgate.

**NOTICE** Lock Tailgate. Do not open or move tailgate while hinges are removed.

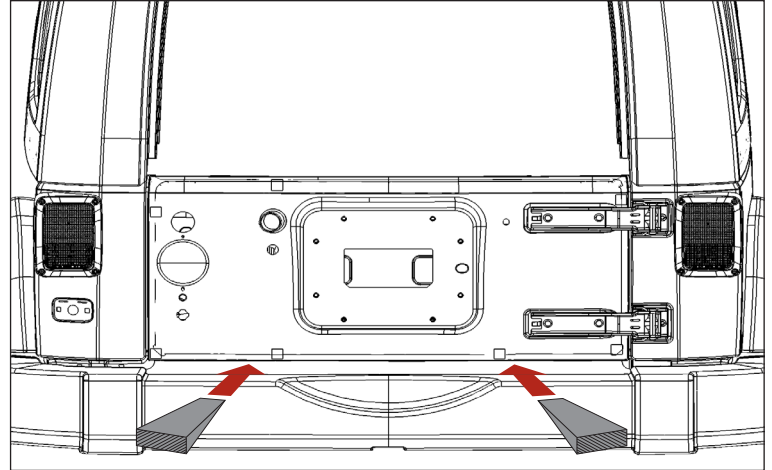

9. Using 13mm socket, remove tailgate hinges from tailgate by removing the 4 bolts indicated on right.

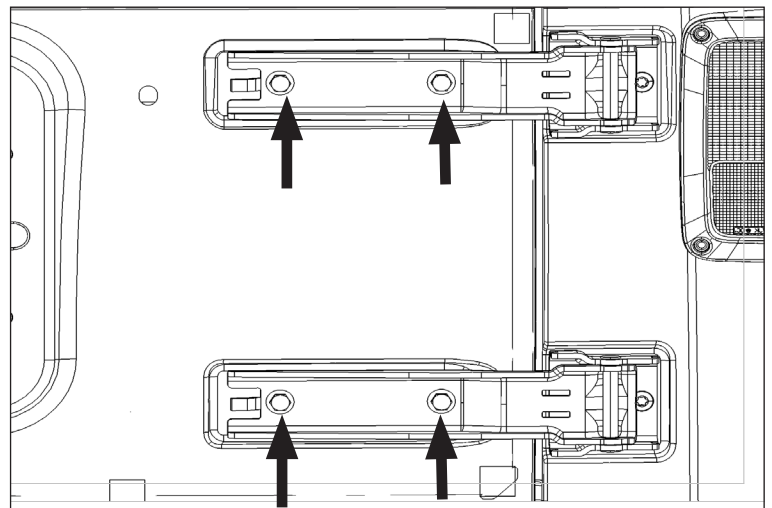

10. Flip hinges to open position. Using a T-50 bit, unscrew stock hinges from vehicle removing the screws indicated at right. This may require using a 10-inch extension with the T-50 bit in order to reach the screws.

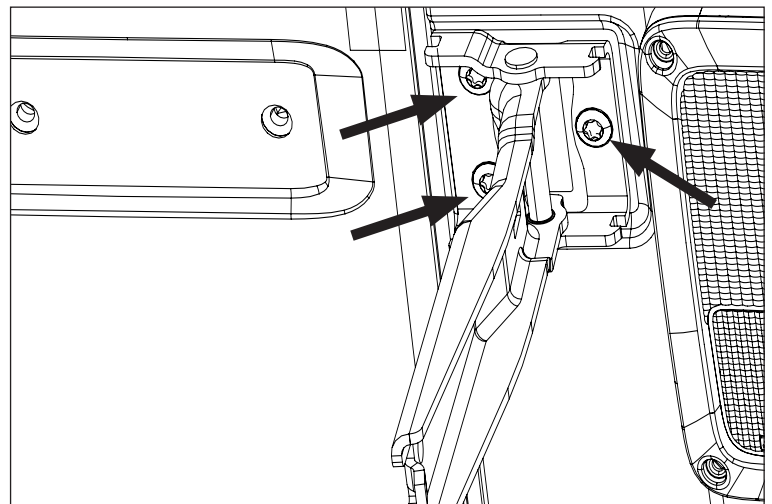



## HD Hinge Casting PATENT PENDING

11. Thoroughly clean any dirt, debris, and corrosion from tailgate and quarter panel where HD Hinge Casting and tire carrier will mount. Painting or priming bare metal under stock hinges is optional, but recommended, especially if corrosion is present.

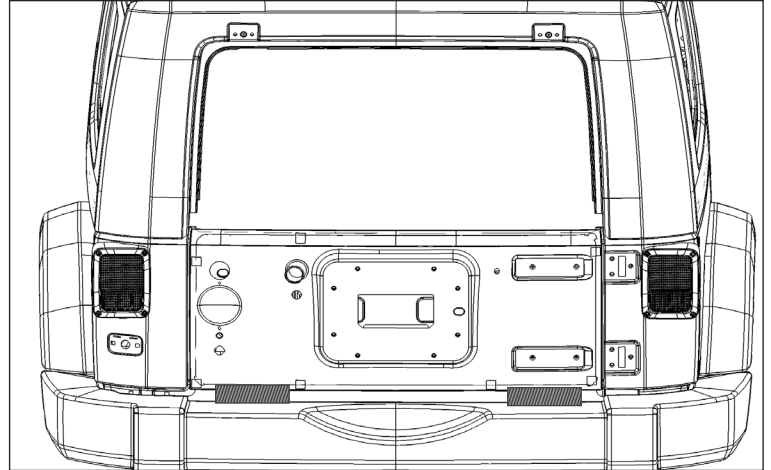

12. Place HD Hinge Casting in position. Reusing 6 factory screws, fasten hinge brackets to vehicle quarter panel. Attach outside screw first, then swing hinge open and install remaining four screws.

Do not fully tighten.

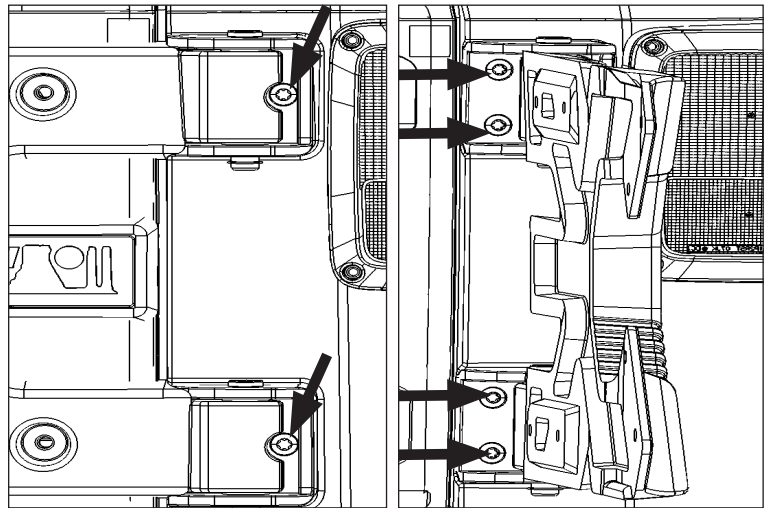

13. Re-using factory bolts and washers removed in step 6, loosely attach right side of HD Hinge Casting.

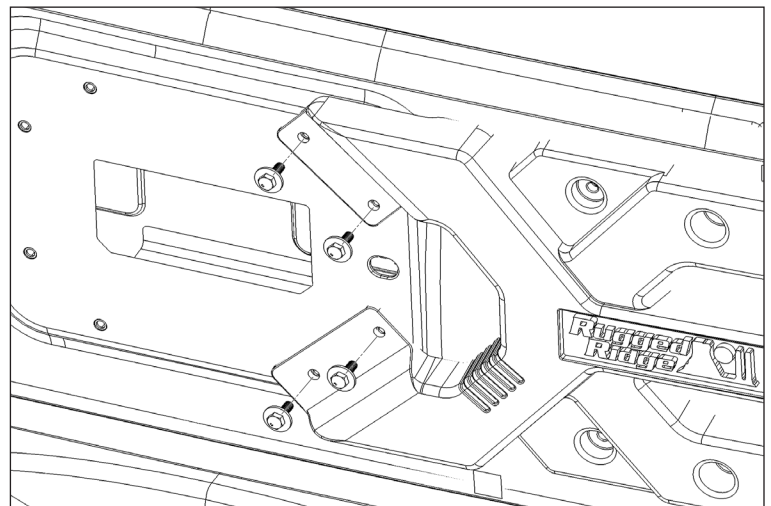



## HD Hinge Casting PATENT PENDING

14. Fully tighten outside hinge bracket bolts.

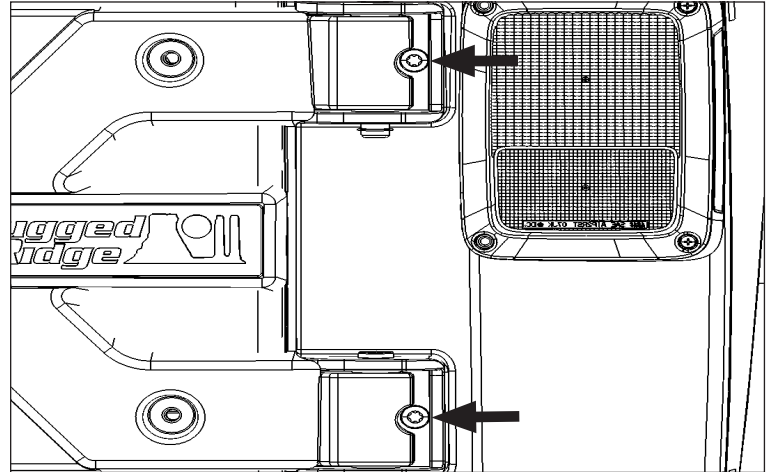

15. Remove the 4 bolts/washers from Step 12. Swing HD Hinge Casting open, making sure not to move the tailgate. Tighten the 4 remaining Torx Head bolts on hinge brackets. Return to closed position.

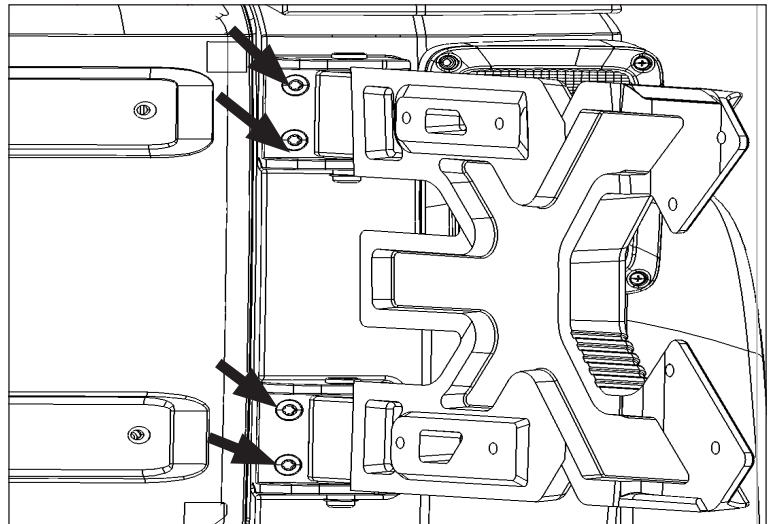

16. If installing the **Rugged Ridge HD Wheel Mount (Part# 11546.52)** with HD Hinge Hinge, stop here and refer to **Step 5** of HD Wheel Mount Instructions.

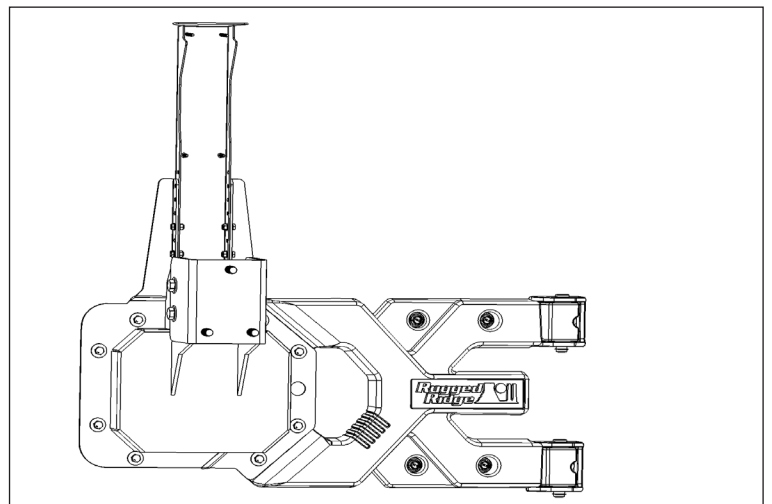



## HD Hinge Casting PATENT PENDING

17. Align tire carrier with tailgate bolt holes and begin threading the four factory bolts on the right hand side of the OE tire carrier. Do not fully tighten.

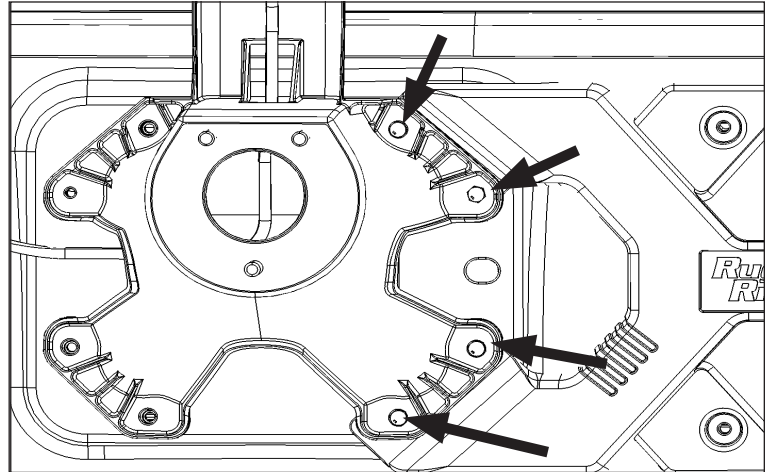

18. Slide spacer plate between tailgate and top left corner of the OE tire carrier. Loosely re-install factory bolts and washers. Repeat for bottom left corner. Some slight shifting of HD Hinge Casting may be required to re-install all 8 tire carrier bolts.

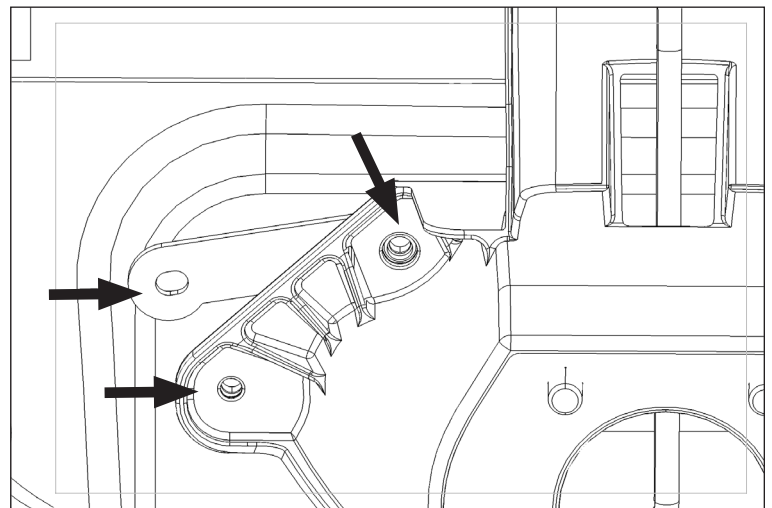

19. Once all bolts are threaded, tighten the 8 bolts around the tire carrier.

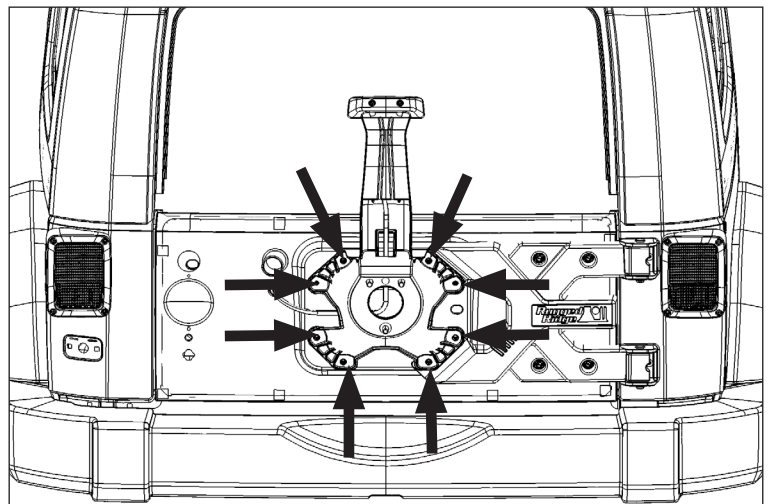





## HD Hinge Casting PATENT PENDING

20. Using a 13mm socket, install the 4 supplied hex bolts and washers to fasten the hinge body to tailgate. Use red thread locker on bolt threads prior to installation, and fully tighten bolts before thread locker dries.

Shims can now be removed.

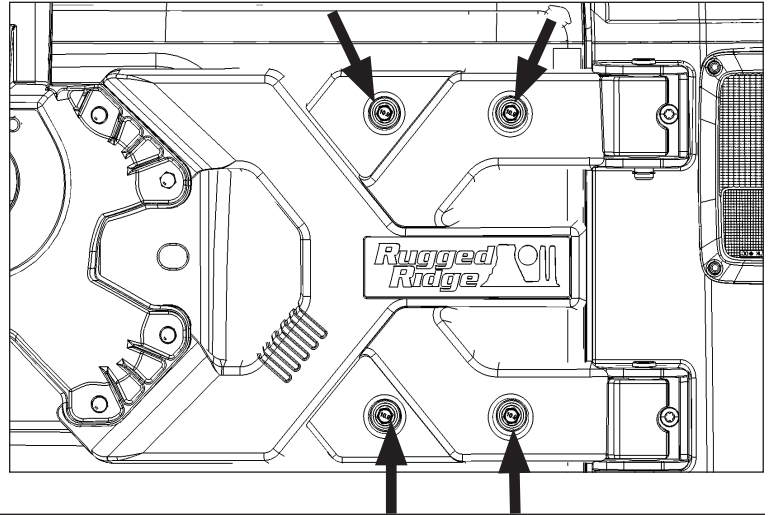

21. Feed the third brake light wire back through the OE tire carrier and reinstall factory brake light.

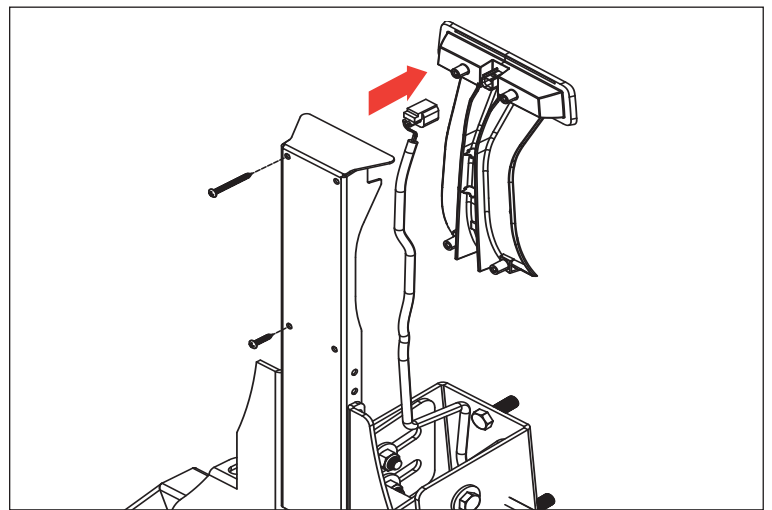

22. Re-install spare tire and factory lug nuts. Use a torque wrench with a 3/4" socket to tighten the lug nuts to 80 lb/ft.

**CAUTION** Have another person help lift the tire onto the carrier.

**WARNING** Failure to tighten the lug nuts to the proper torque specification of 80 lb/ft could result in serious injury or property damage.

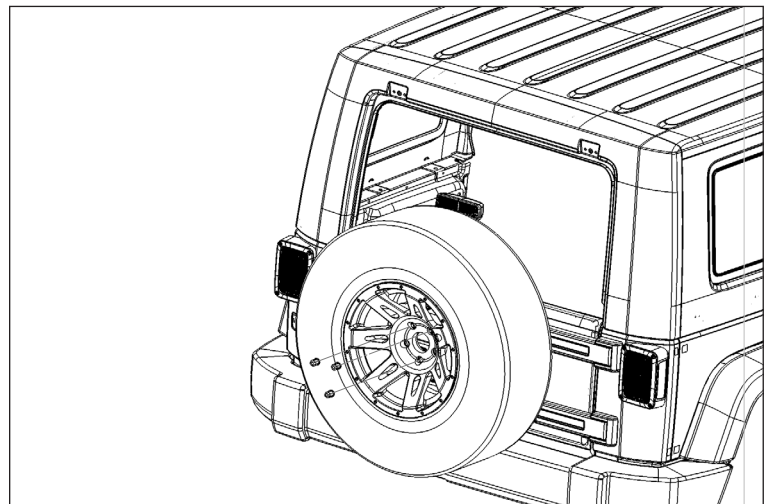

## HD Wheel Mount

### CONTENTS:

Main Plate	(1)
Lug Plate	(1)
Brake Light Extender	(1)
Spacer Plates	(2)

### HARDWARE:

M6 Bolt	(4)
M6 Washer	(8)
M6 Lock Nut	(4)
M8 Bolt	(8)
M8 Washer	(8)
M12 Bolt	(4)
M12 Washer	(8)
M12 Lock Nut	(4)
M12 Set Screw	(2)
#10 Phillips Screw - Long	(2)
#10 Phillips Screw - Short	(2)
Lug Nuts	(3)
Butt Connectors	(4)
Wire	(2)

### TOOLS REQUIRED:

Socket Wrench
13mm Socket
10mm Socket
10mm Wrench
19mm Socket
19mm Wrench
3/4" Deep Socket
Torque Wrench
6mm Allen Wrench
T-20 Torx bit
Phillips Head Screwdriver
Wire Cutters/Crimpers

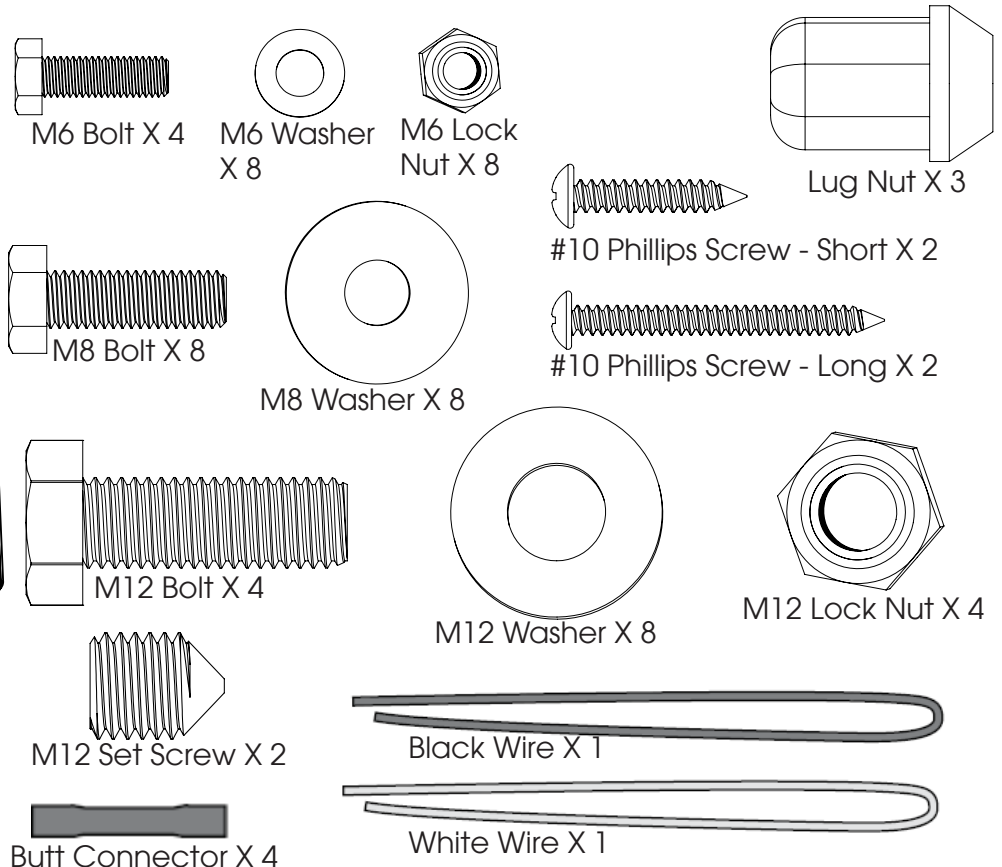
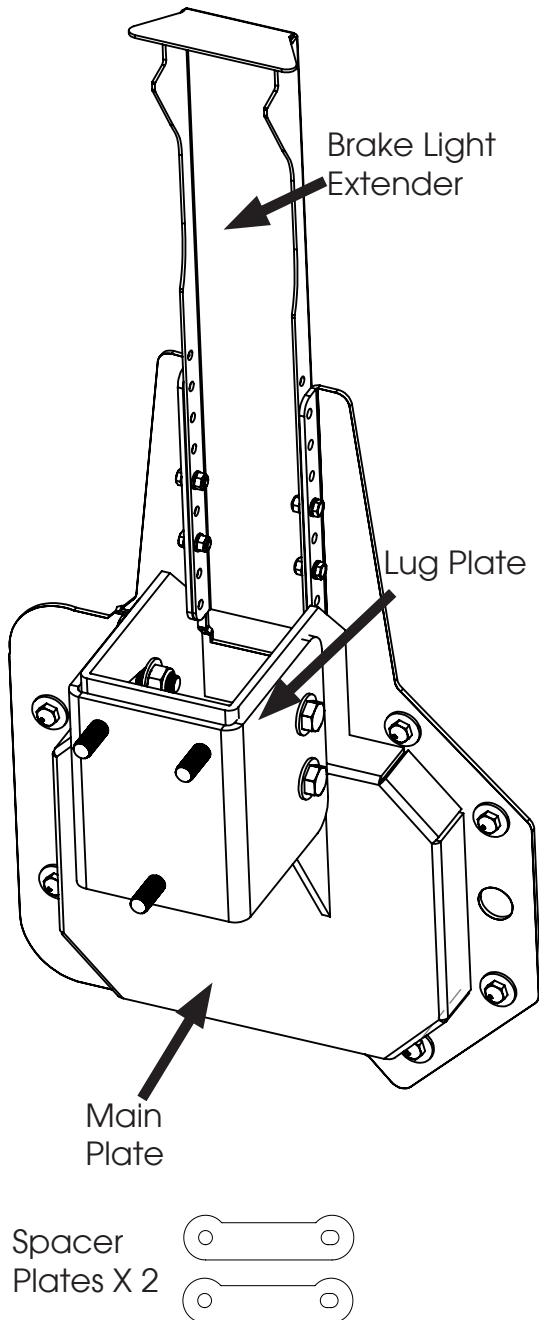



## HD Wheel Mount

### Important Safety Information

Your Rugged Ridge® Tire Carrier is intended to increase the utility and enjoyment of your Jeep® by providing easy access to your rear cargo area and secure mounting of your off-road spare tire. Before installation, please take a moment to review the following safety information and installation instructions. Important safety information is generally preceded by one of three signal words indicating the relative risk of injury. The signal words mean:

#### **WARNING**

A hazardous situation which, if not avoided, could result in serious injury or death. **You can be killed or seriously hurt if you do not follow instructions.**

#### **CAUTION**

A hazardous situation which, if not avoided, could result in minor or moderate injury. **You can be moderately hurt and may also suffer property damage if you do not follow instructions.**

#### **NOTICE**

Careful attention is required to this instruction or operation, but does not generally relate to personal injury. Damage to your product or other property may result if you do not follow instructions.

### Installation Instructions

To reduce risk of personal injury during assembly and use of this product:

- Wear gloves and safety glasses during installation.
- Tire Carrier and spare tire/wheel are heavy. Use jack or seek assistance when lifting, fastening parts, or installing wheel/tire to carrier.
- Tire Carrier is subject to vibration and shock loads from on and off road use. Regularly inspect carrier and lug nuts fastening spare to carrier. Do not use and repair if damaged. Use thread locker and keep lug nuts torqued to 80 ft./lbs.



## HD Wheel Mount

**NOTICE** - If using the **HD Wheel Mount** with the **Rugged Ridge HD Hinge Casting (Part# 11546.51)**, it is necessary to install the **HD Hinge Casting** first. Please stop here and refer to the **11546.51 HD Hinge Casting Instruction sheet**.

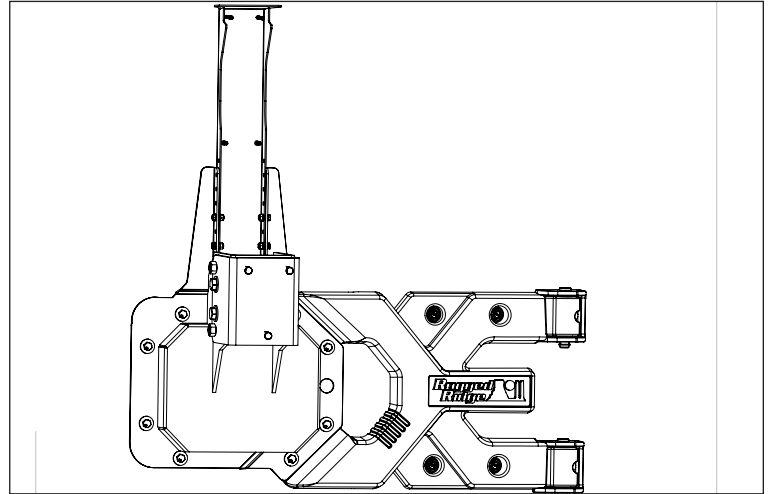

1. Take off the spare tire by removing the 3 lug nuts using a 3/4" deep socket.

**CAUTION** Have another person help lift the tire off of the carrier.

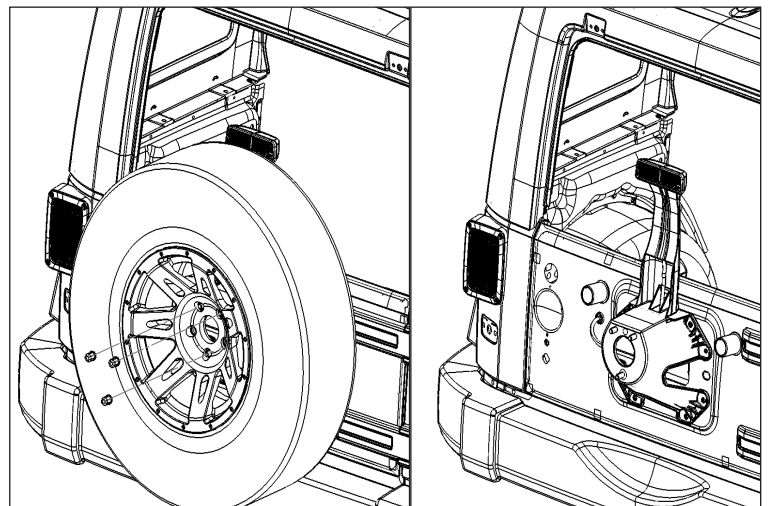

2. Open the tailgate. Using a T-20 Torx bit, remove 4 torx head screws that attach light to factory tire mount. Pull light away from tire mount.

3. Remove connector by pushing down on tab and pulling. Set light aside, it will be used later during installation. Place connector and wires off to side to not interfere with Tire Carrier installation.

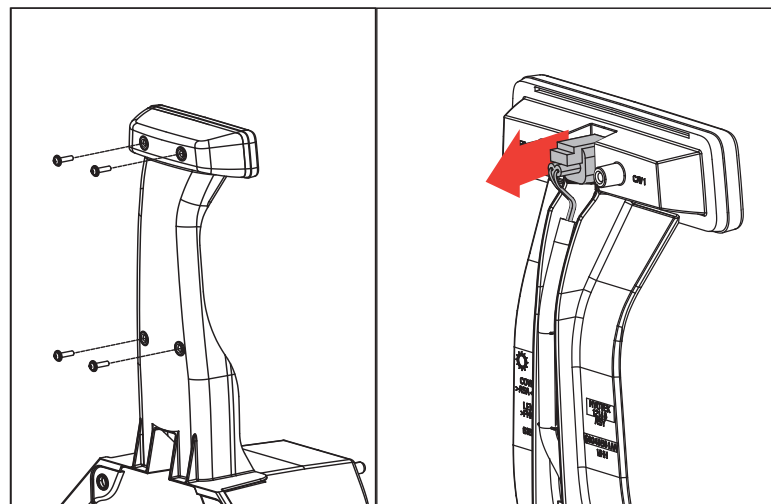

## HD Wheel Mount

4. Remove the stock tire carrier and brake light holder by removing the 8 bolts indicated using a 13mm socket.

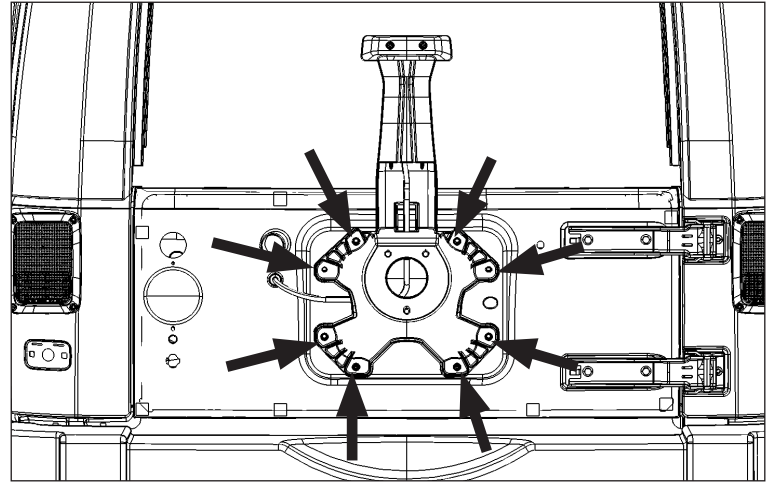

5. Position Wheel Mount Main Plate in place on the tailgate. Use a 13mm socket to loosely thread 4 of the supplied M8 bolts and washers on the left side of the Wheel Mount. Do not fully tighten.

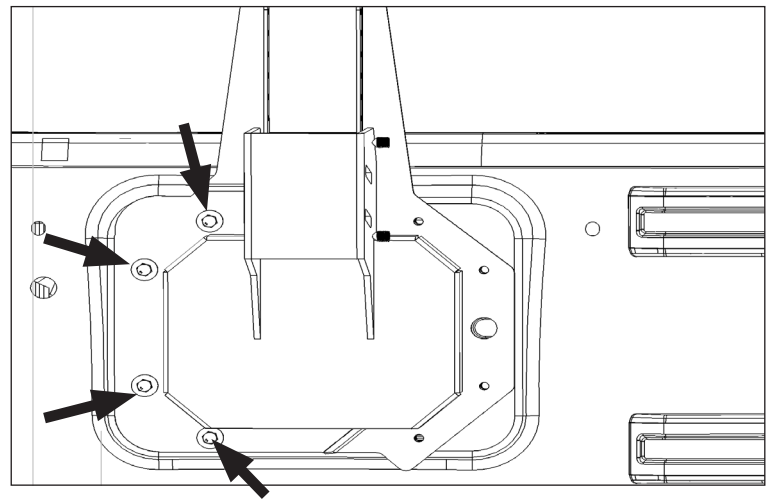

**6A. If using the stock tailgate hinges,** slide spacer plate between tailgate and top right corner of Wheel Mount. Loosely install M8 bolts and washers with a 13mm socket. Repeat for bottom right corner. Fully tighten all 8 bolts.

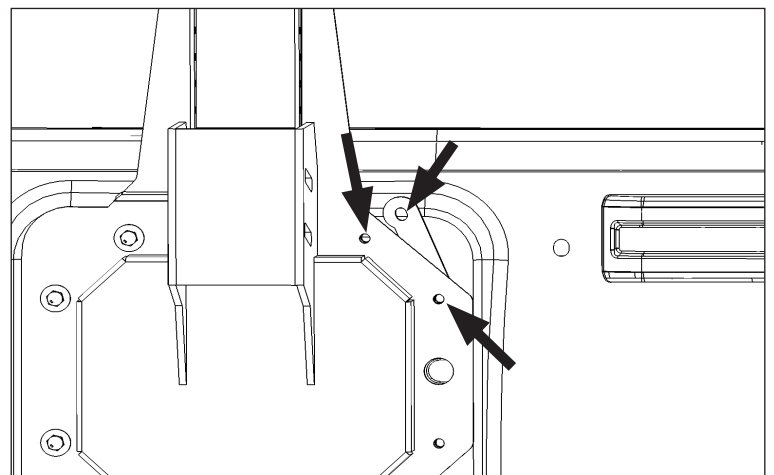

## HD Wheel Mount

**6B. If using with the HD Hinge Casting (part# 11546.51), no spacers are required. Position Wheel Mount and install and fully tighten all 8 M8 bolts and washers in steps 5 and 6A with a 13mm socket.**

Then, with the 13mm socket, install the 4 hex bolts and washers, included with the HD Hinge Casting, at indicated areas to fasten the hinge body to tailgate. Use red thread locker on bolt threads prior to installation, and fully tighten bolts before thread locker dries.

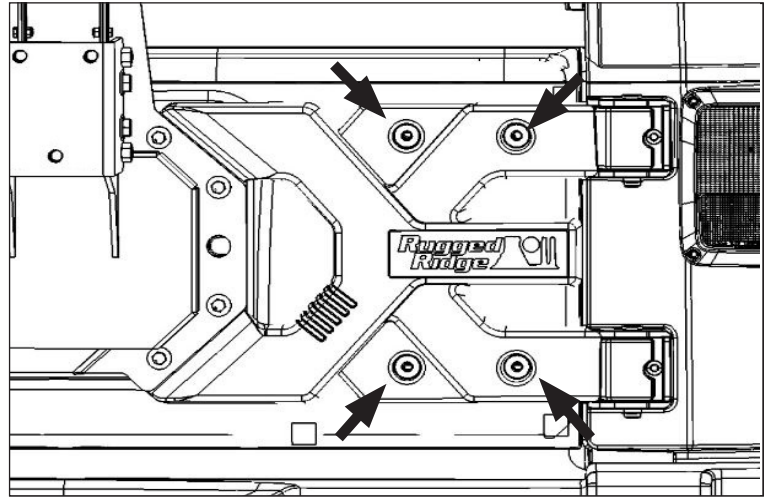

7. Slide Lug Plate onto main carrier plate.

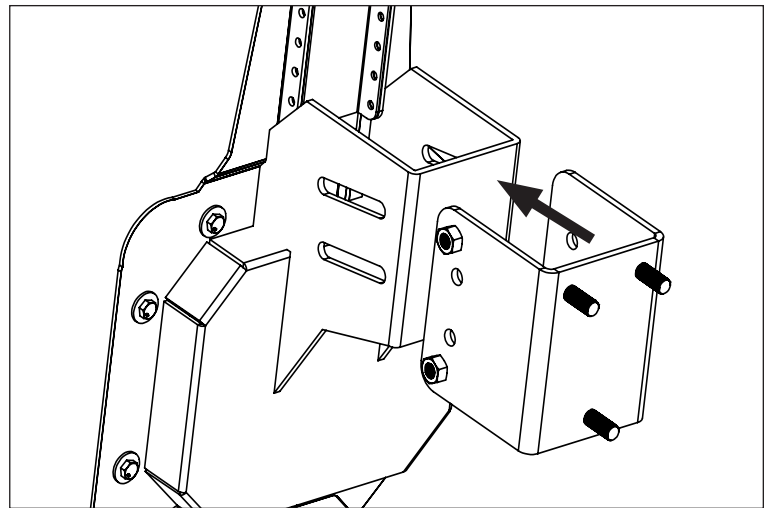

8. Using a 19mm wrench and socket, loosely secure the Lug Plate to the Main Plate with the supplied M12 Hardware. Do not fully tight yet. Bolts should be tight enough to prevent Lug Plate from moving freely, but loose enough to manually adjust its position and orientation.

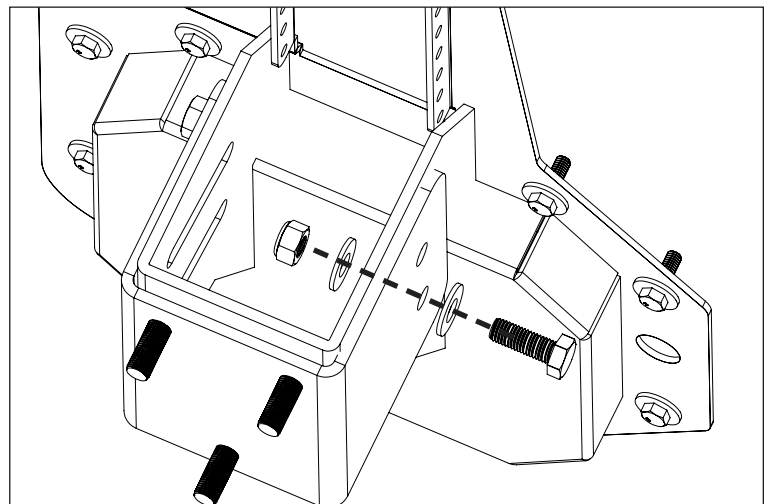

## HD Wheel Mount

9. Install spare tire and lug nuts onto Lug Plate. Manually adjust position/angle of the spare tire. Install and tighten 2 set-screws using a 6mm allen wrench to hold Lug Plate in position.

**CAUTION** Have another person help lift the tire onto the carrier.

**WARNING** When adjusting wheel position, make sure wheel and tire are as close as possible to the vehicle/Wheel Mount without touching. If mounted too far away from vehicle, it can cause unnecessary stress or damage, which could result serious injury or damage to property.

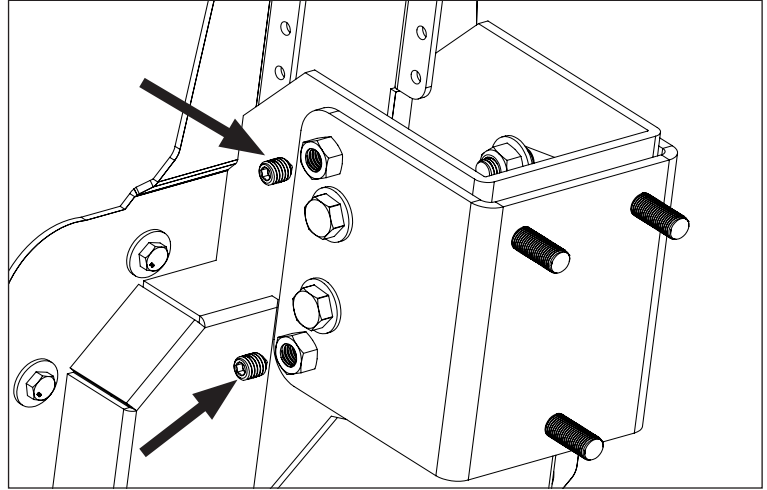

10. Using a 10mm wrench and socket, install Brake Light Extension using supplied M6 bolts, washers, and nylon lock nuts.

**CAUTION** Your Jeep® high-mounted brake light is mandatory highway safety equipment. Do not delete and ensure light is visible over your choice of spare wheel/tire. Final position of light may need to be adjusted to ensure proper visibility once brake light and spare tire is mounted (see instructions below).

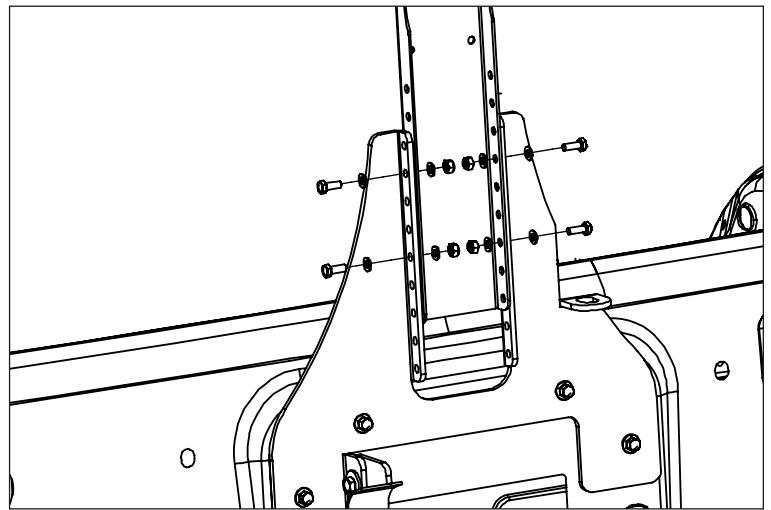

11. Gently remove spare tire, making sure lug plate does not change position. Fully tighten all four M12 bolts/nuts to secure lug plate to Main Plate using a 19mm wrench and socket.

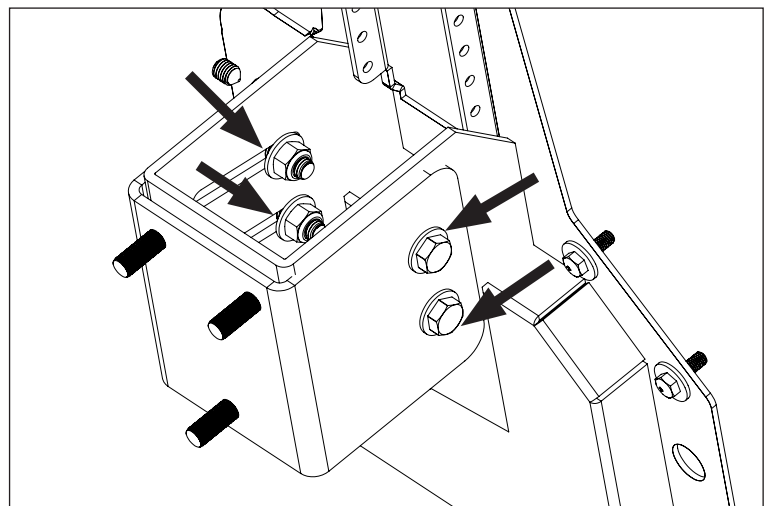

## HD Wheel Mount

12. Once Tire Carrier installation is complete, before installation of spare tire, reconnect wires to factory third brake light by pushing connector until it clicks.

13. Install factory third brake light to Brake Light Extension using provided #10 screws and phillips head screwdriver. Long screws are for top two holes. Short screws are for bottom two holes.

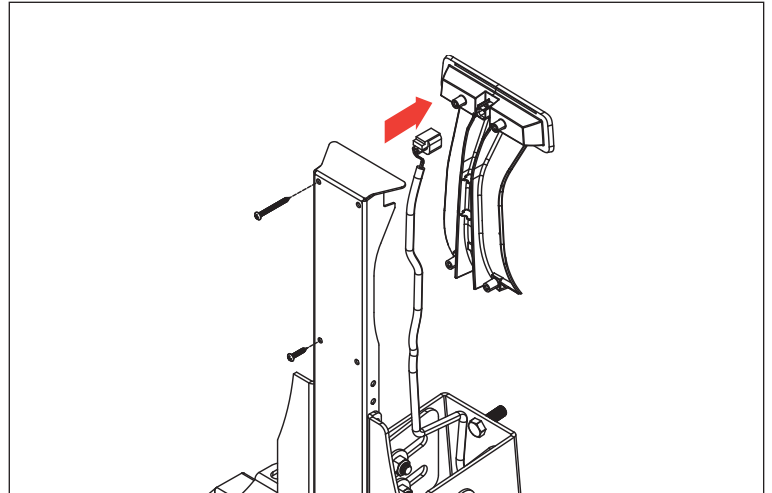

**OPTIONAL:** For larger spare tires, it may be necessary to raise Brake Light Extension to be seen over spare tire. This may require additional wire to be spliced and added to factory third brake light wires.

14. Open tailgate and remove plastic vent by pulling on left side until clips release.

15. Unplug connector by pushing in tab and pulling down.

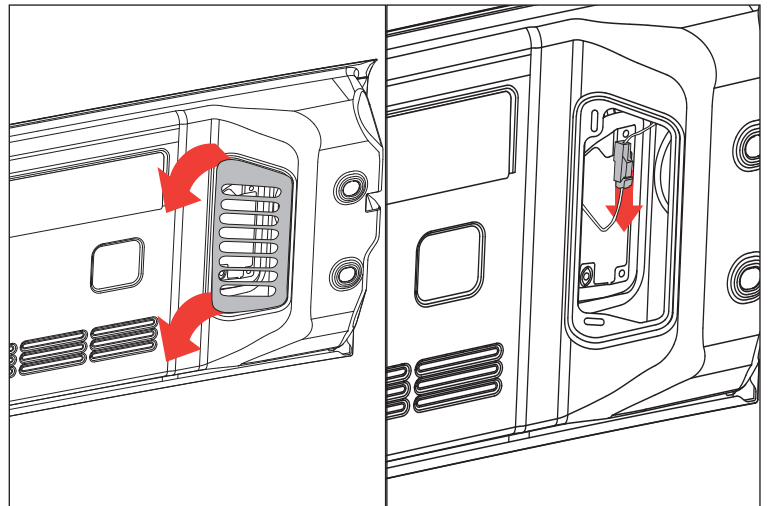

16. Remove rubber grommet in tailgate. Hold grommet tightly in one hand, and pull the wire through the grommet to increase the length of wire that is coming out of the grommet.

17. If the wire is still not long enough, additional wire must be spliced in using the supplied wire and connectors. In the section of wire between uppermost connector and mesh cover, use wire cutters/crimpers to cut and splice in additional wire length.

18. Reinstall rubber grommet in tailgate. Reconnect wire connector inside tailgate. Reinstall plastic tailgate vent.

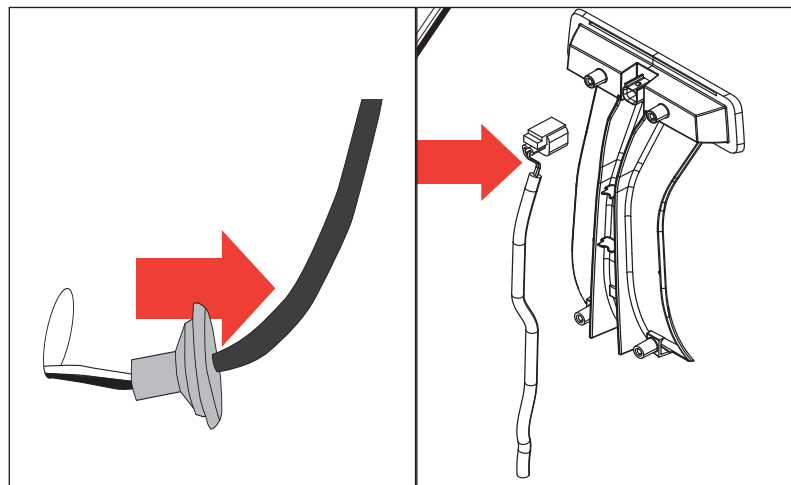



## HD Wheel Mount

19. Install spare tire and supplied lug nuts back onto tire carrier. Use a torque wrench with a 3/4" deep socket to tighten the lug nuts to 80 lb/ft.

**CAUTION** Have another person help lift the tire onto the carrier.

**WARNING** Failure to tighten the lug nuts to the proper torque specification of 80 lb/ft could result in serious injury or property damage.

