

XOR Stubby Bumper, Front; 18-20 JL, 20 JT

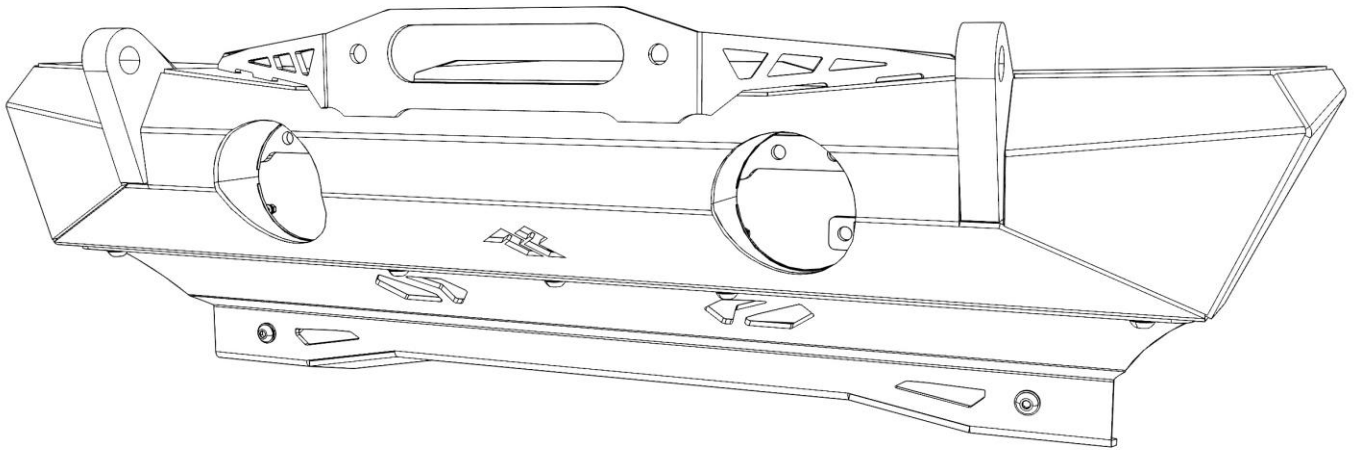
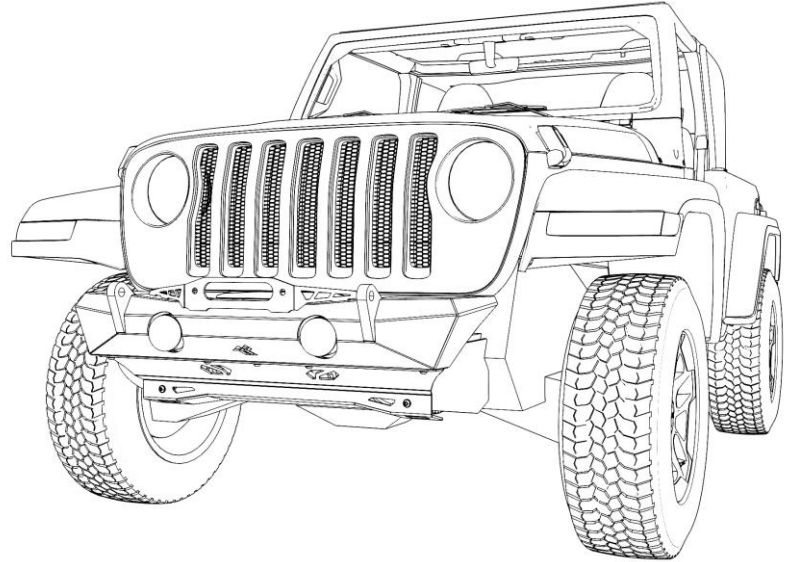

ATTN: STATE OF CALIFORNIA CONSUMERS

⚠ WARNING: Cancer and Reproductive Harm

XOR Stubby Bumper, Front; 18-20 JL, 20 JT

Components

1. XOR Front Bumper for 18-20 Jeep Wrangler JL (1) – Upper Bumper and Lower Skid Plate
2. Fog Light (2) – OE Sahara Trim or Non-LED Sport (Not Included)
3. Sport Fog Light Mounting Bracket

OE Sahara Trim

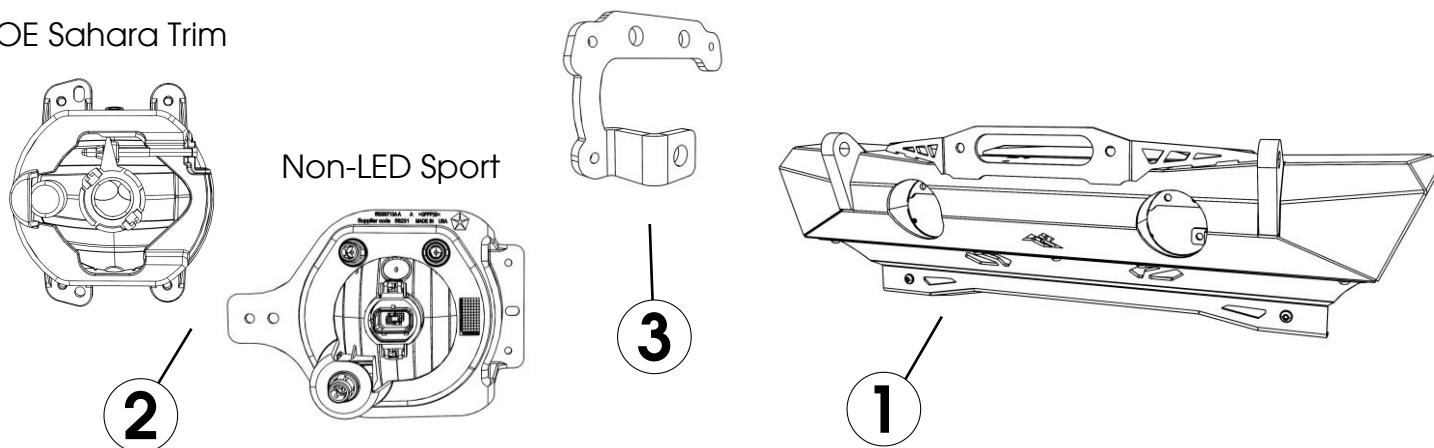

Hardware

1. M10 Flat Washer (9)
2. M10 NyLock Nut (9)
3. M10 x 30mm Button Head Screw (7)
4. M4 Carriage Bolt (8)
5. M4 Flat Washer (8)
6. M4 Lock Washer (8)
7. M4 Hex Nut (8)
8. M12 Flat Washer (6)
9. M12 NyLock Nut (6)
10. M12 x 40mm Hex Head Screw (6)

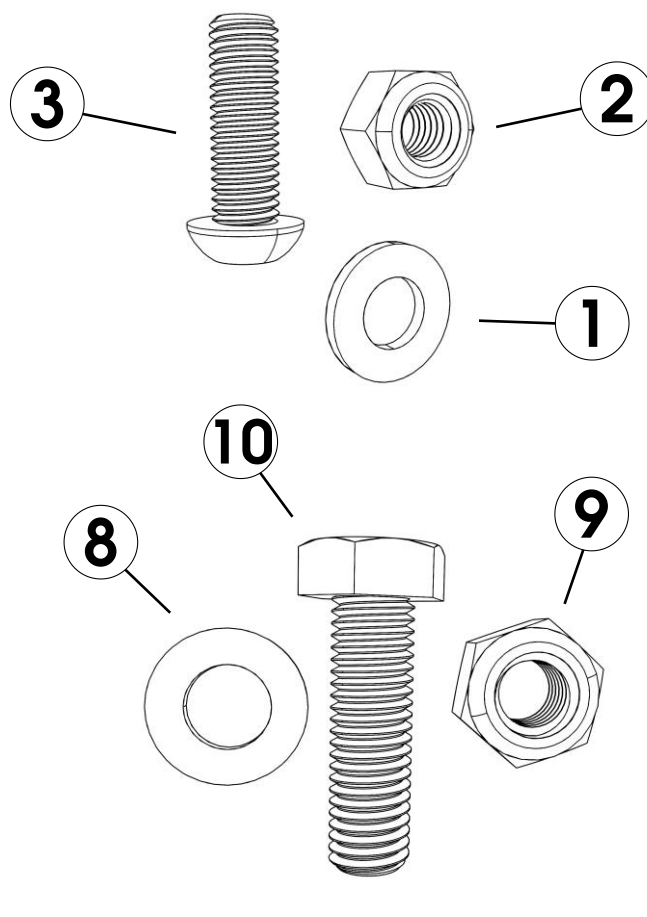

XOR Stubby Bumper, Front; 18-20 JL, 20 JT

INSTALLATION INSTRUCTIONS

1. Disconnect the fog light harness connectors and remove the OE bumper from the Jeep. See Jeep documentation for instructions if needed.

NOTICE

OE Rubicon Steel Bumper fog lights and Sport LED fog lights will not work with the XOR Stubby Front Bumper.

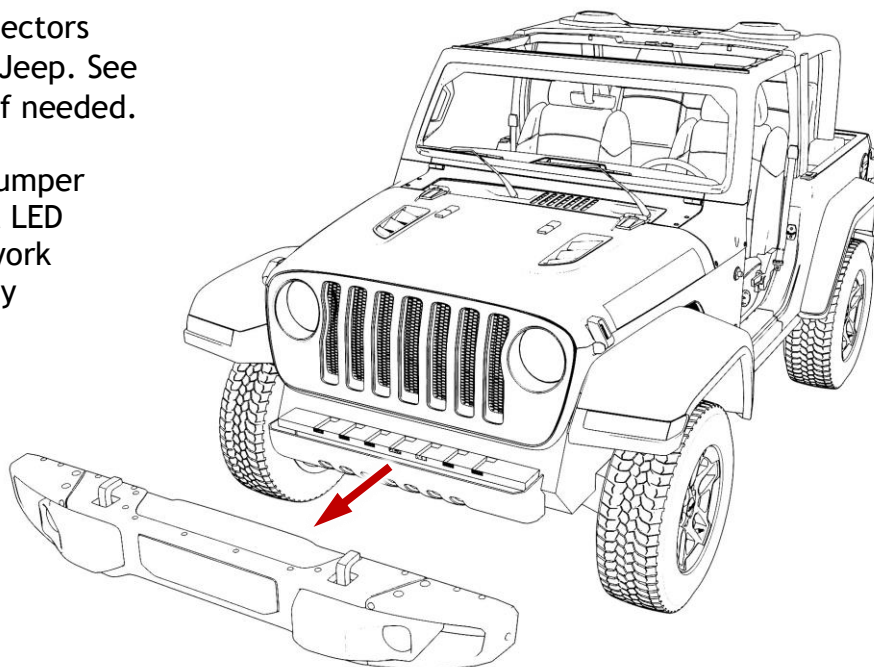

2. If installing Sport fog lights, skip to Step 4. If installing OE Sahara Trim fog lights into the XOR bumper, remove the OE fog lights from the OE bumper (see Jeep documentation if needed). Use a 17/32 drill bit to enlarge the mounting holes on the Sahara Trim fog lights.

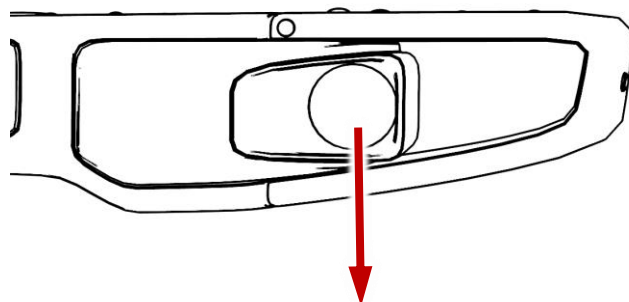

ENLARGE HOLES
WITH 17/32
DRILL BIT

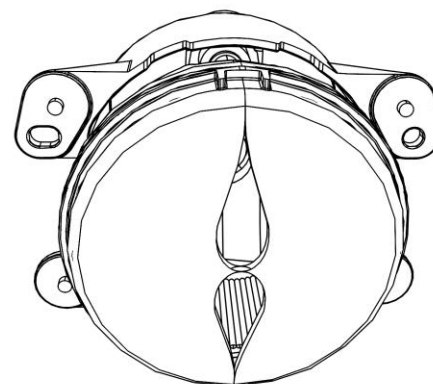
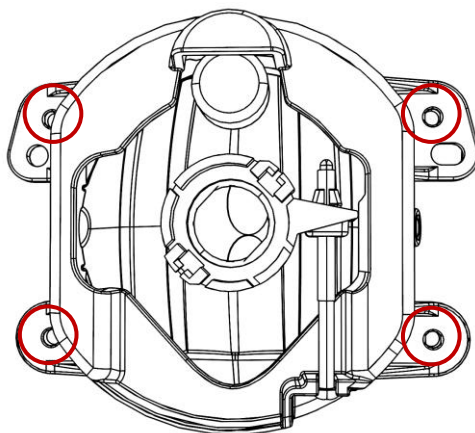

XOR Stubby Bumper, Front; 18-20 JL, 20 JT

3. Insert one (1) M4 Carriage Bolt from the bottom up into one of the mounting points on the upper component of the XOR Stubby Front Bumper. Attach the fog light and secure it by installing one (1) M4 Flat Washer, one (1) M4 Lock Washer, and one (1) M4 Hex Nut, in that order. Repeat for the other three mounting points. Repeat process for the other fog light.

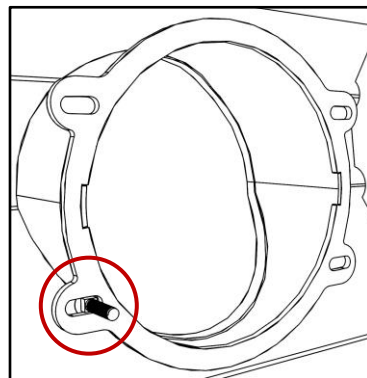

NOTICE

Do not overtighten the hardware on the plastic housing, as this can cause damage.

THIS SIDE UP

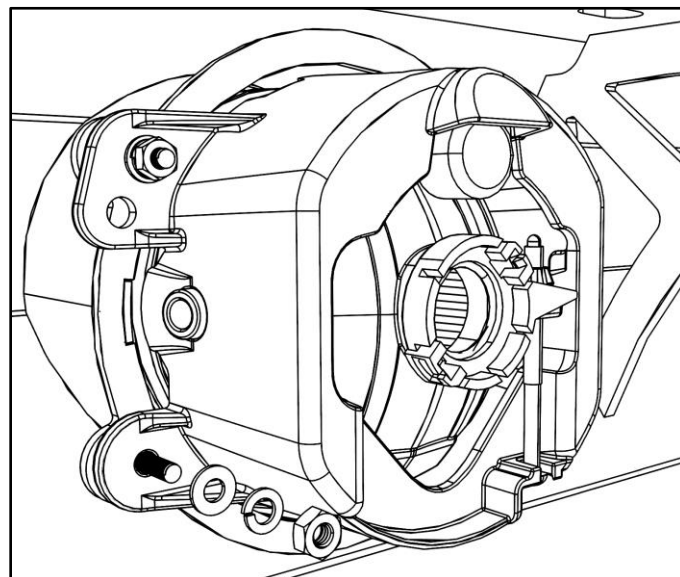
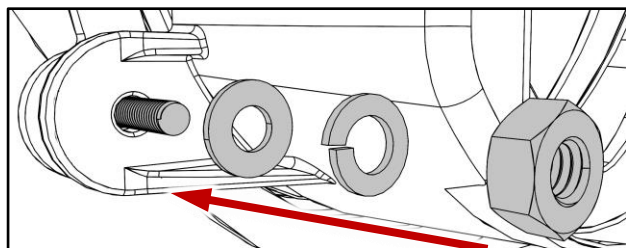
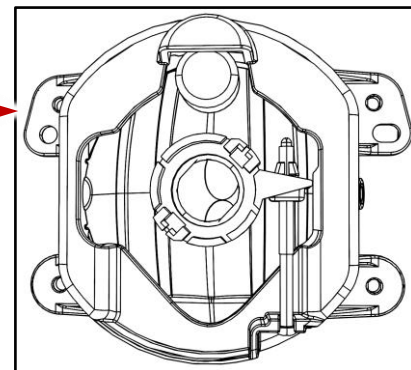
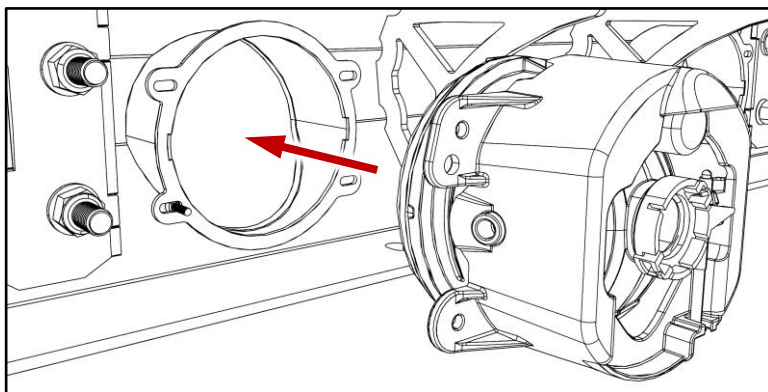

XOR Stubby Bumper, Front; 18-20 JL, 20 JT

4. If installing OE Sahara Trim fog lights, refer to Steps 2 and 3. To install the Sport fog lights, first remove the OE bracket by pressing in on the protrusion clips and pulling it off. Mount the Sport fog light to the three mounting points on the bracket. The protrusions on the fog light will snap into place on the bracket. Insert one (1) M4 Carriage Bolt from the bottom up into one of the mounting points on the upper component of the XOR Stubby Front Bumper.

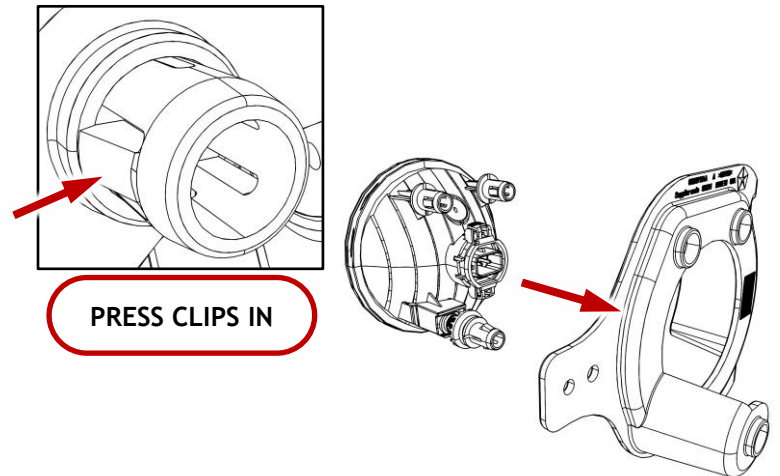

Attach the Sport fog light and secure it by installing one (1) M4 Flat Washer, one (1) M4 Lock Washer, and one (1) M4 Hex Nut, in that order. Repeat for the other two mounting points. Repeat process for other fog light.

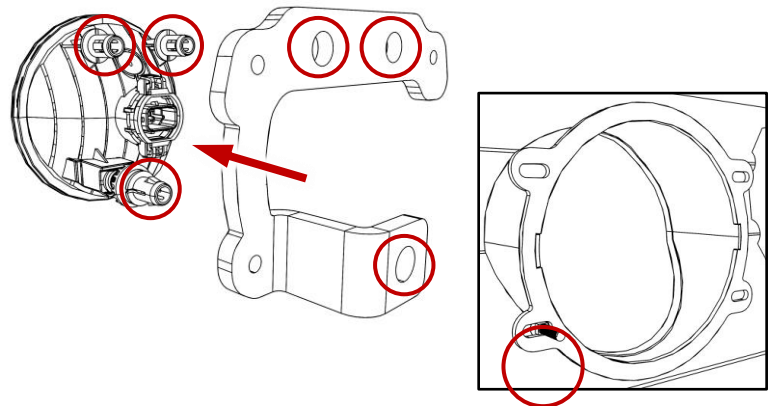

NOTICE

Do not overtighten the hardware on the plastic housing, as this can cause damage.

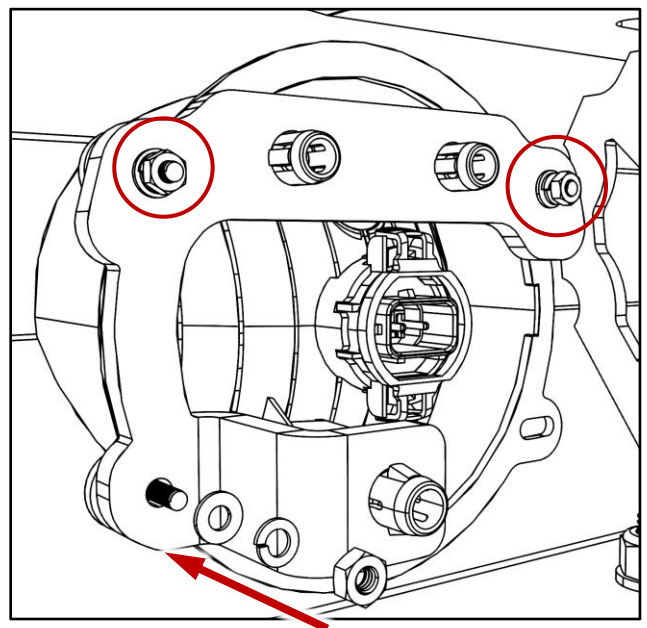
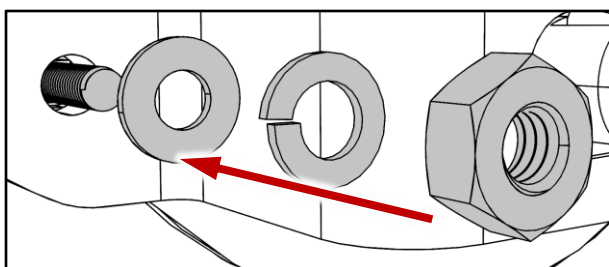
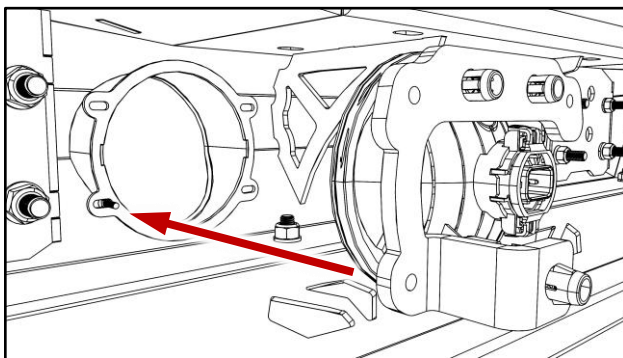

XOR Stubby Bumper, Front; 18-20 JL, 20 JT

5. Observe the four studs on each end of the upper component of the bumper. On the driver side, the top left stud will receive one (1) M10 Flat Washer and one (1) M10 NyLock Nut after the bumper has been attached to the frame horn. The pictures shown depict the bumper and hardware before it has been attached. On the passenger side, the top right stud will receive the same hardware. The other three bolts on each end will receive one (1) M12 Flat Washer and one (1) M12 NyLock Nut each.

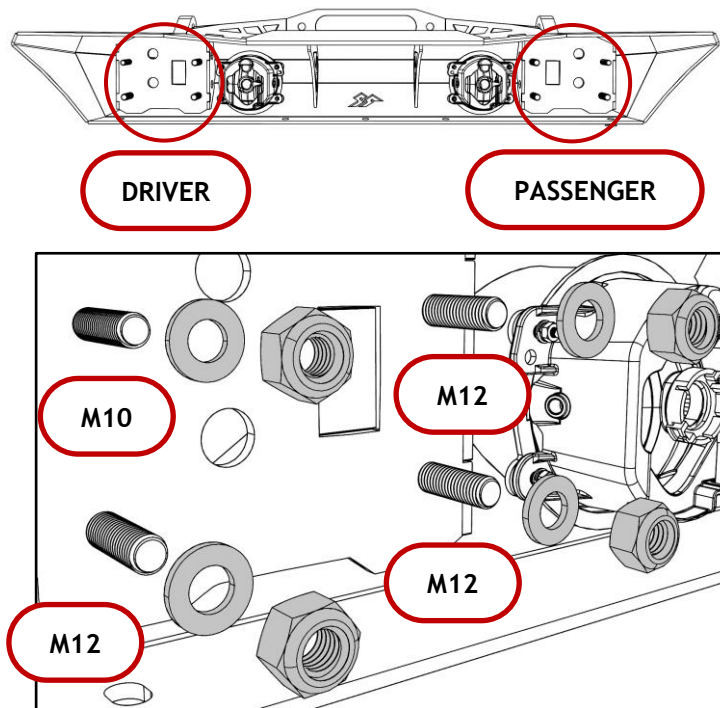

INVERSE FOR PASSENGER SIDE

6. Attach the upper component of the XOR Stubby Bumper to the frame horn. Slide the studs into the mounting points. Attach the hardware in the configuration shown in Step 5 to secure the bumper to the frame horn. Tighten all hardware.

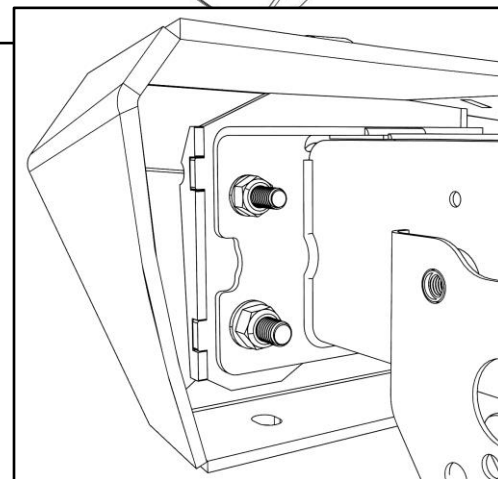
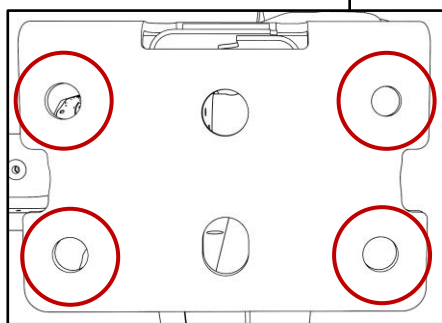
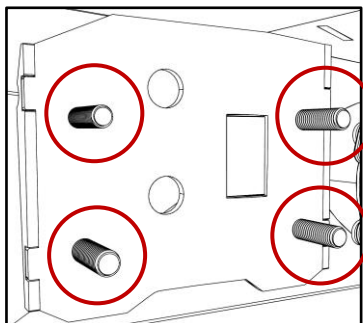
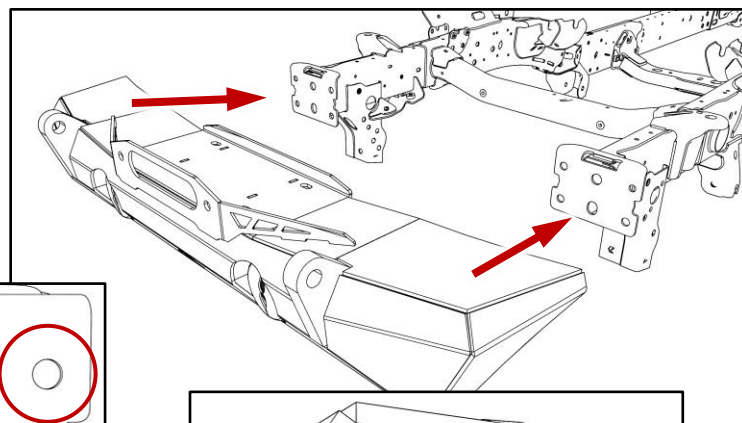

XOR Stubby Bumper, Front; 18-20 JL, 20 JT

7. Reattach the Jeep wire harness fog light connectors to the connection points on the fog lights. Zip-tie the harness as needed to prevent any dangling or pinching.

RECONNECT WIRE HARNESS
FOG LIGHT CONNECTOR

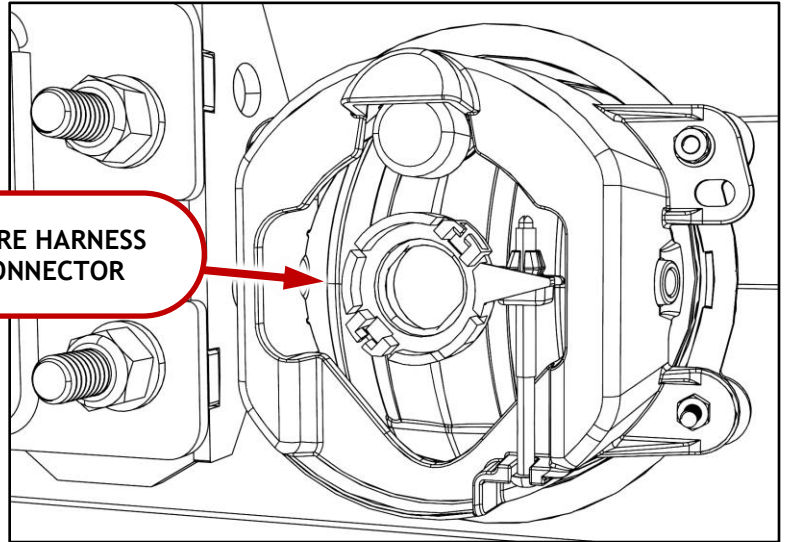

8. Attach the lower skid plate of the XOR Stubby Front Bumper to the flange (underside) of the bumper and to the frame horn extension pieces. Starting with the center of the flange, align the five (5) holes and install the five (5) M10 Flat Washers and M10 x 30mm Button Head Screws in the front. Fasten five (5) M10 NyLock Nuts in the back. Don't tighten anything yet.

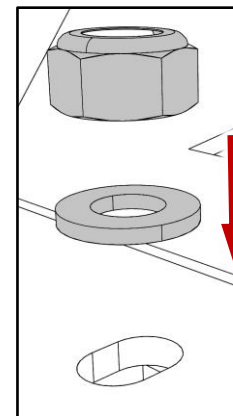
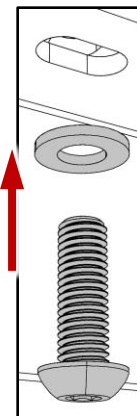
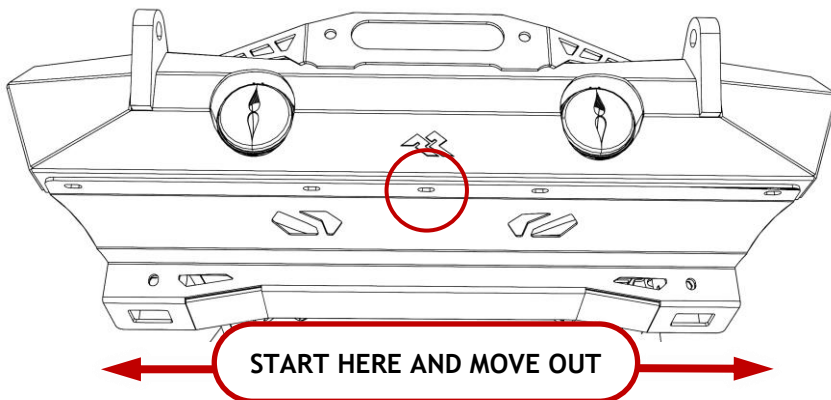
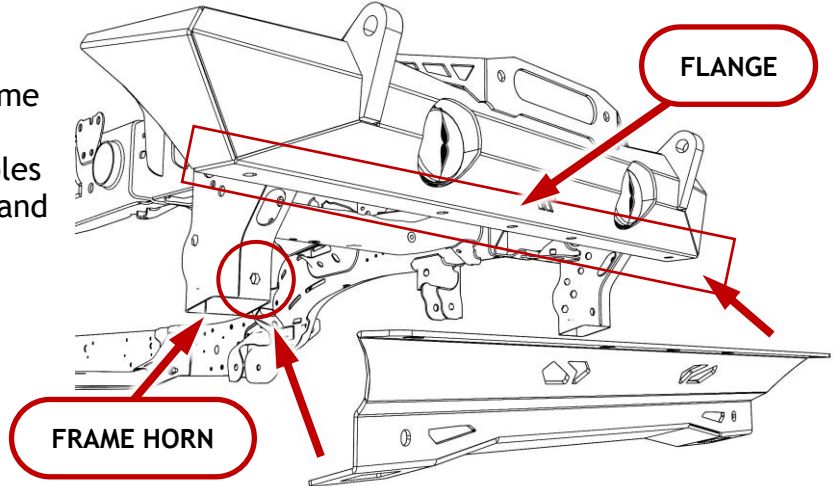

XOR Stubby Bumper, Front; 18-20 JL, 20 JT

9. Install one (1) M10 Flat Washer and one (1) M10 x 30mm Button Head Screw on each frame horn and skid plate end. In the interior of each frame horn, attach one (1) M10 NyLock Nut to the screw.

After making sure everything is snug and aligned correctly, tighten hardware using a 6mm Allen wrench on the M10 x 30mm Button Head Screws and a 14mm socket wrench.

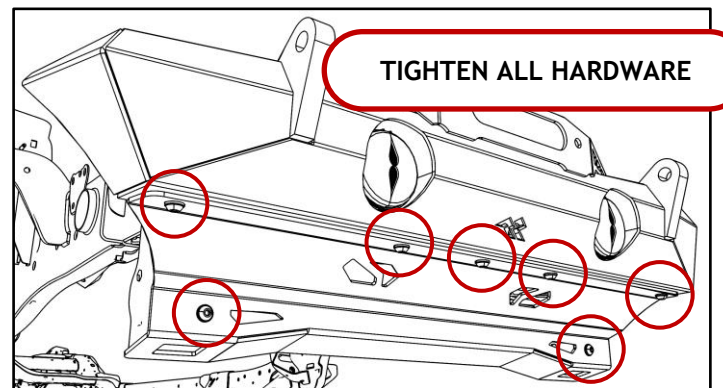
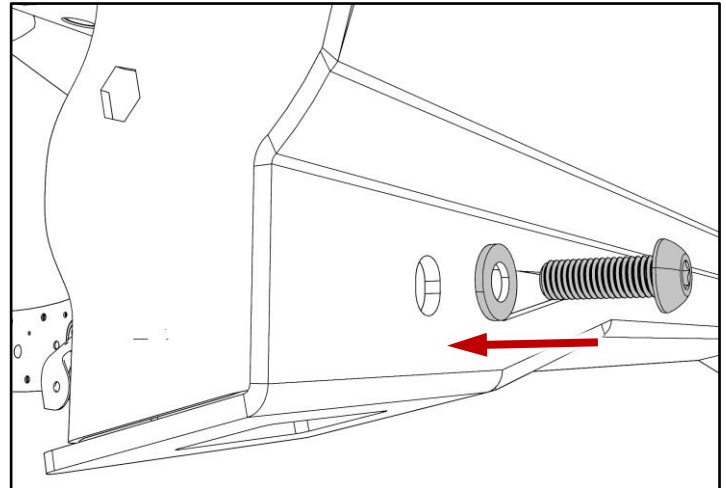
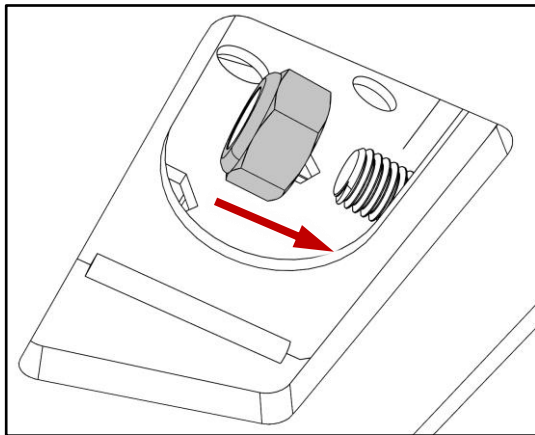

10. The XOR Stubby Front Bumper is now installed.

