

Jeep® JK Wrangler Modular HD Front Bumper - Spacers for use with Warn® Powerplant Winch

Contents:

1. Spacer Blocks (2)
2. 3/8-16 x 2.25" Bolts (4)
3. 3/8 Flat Washer (4)
4. 3/8 Lock Washer (4)

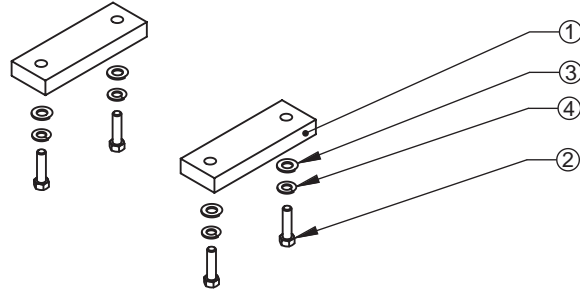

Note: Spacer Blocks are required when using the Warn® Powerplant Winch. Most winches can bolt directly to the Bumper without using these.

1. Winch can be installed with the Bumper on or off of the vehicle. Remove any Hoops from the Bumper. Install Fairlead to Bumper. Note - bolts for Fairlead (supplied with it) should pass from inside the Winch cavity, with the nut being installed on the outside (Figure 1a). Tighten Fairlead bolts (Figure 1b).

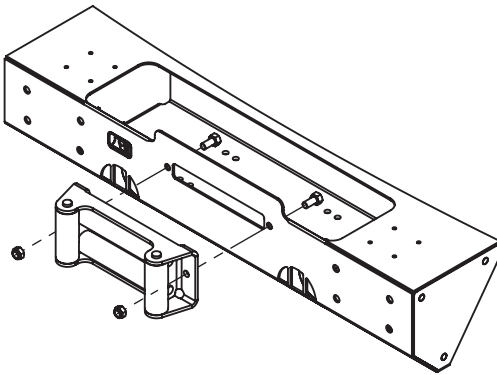

Figure 1a

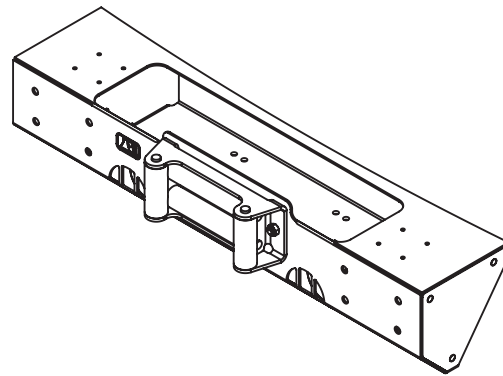

Figure 1b

2. Prepare Winch and vehicle for installation as specified in winch installation instructions. Align holes in bumper as shown below (Figure 2a) with Spacers and winch mounting holes (Figure 2b). It may be helpful to thread winch cable through fairlead before bolting it in place. Install winch as instructed by winch manufacturer, but substitute standard bolts supplied with the winch for longer bolts supplied with the spacers.

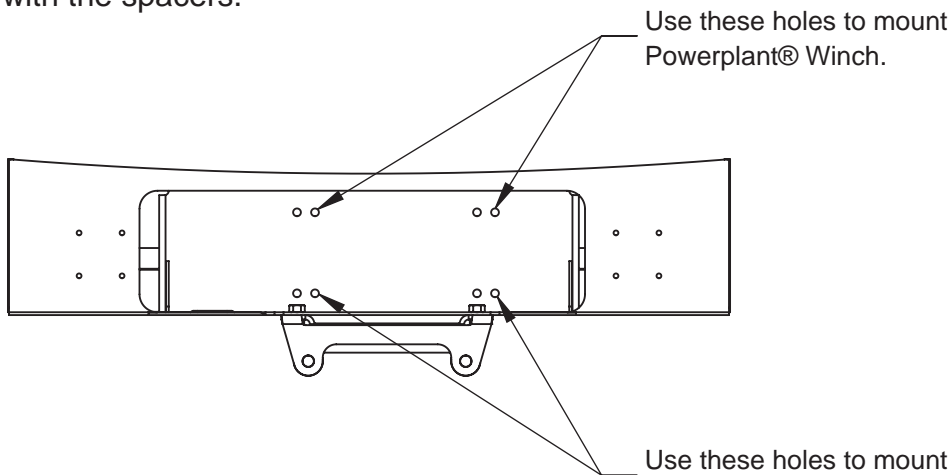

Figure 2a

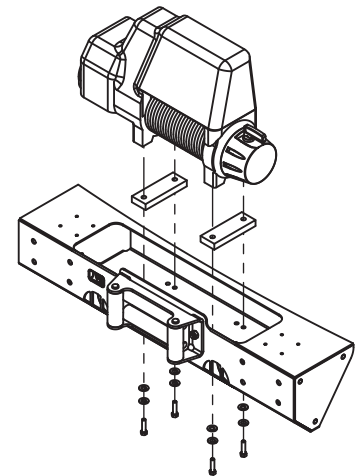
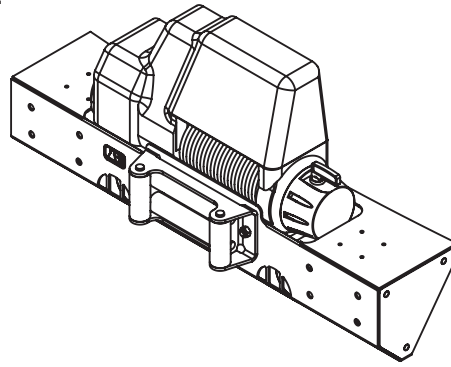
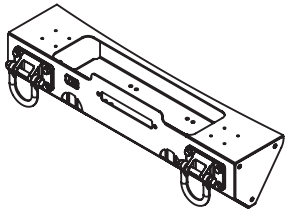

Figure 2b

3. Once all 4 Winch bolts have been started, tighten them. Installation of the Winch and the Winch Spacers is now complete! Proceed with the remainder of the installation as demonstrated in the main Bumper Installation Instructions.



Congratulations on the purchase and installation of a quality Rugged Ridge product! Ask your retailer about the following additional accessories to the JK Modular HD Bumper:



11540.10 - Winch Center Section

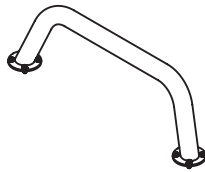

11540.14 - Optional Hoop - Black
11540.16 - Optional Hoop - Stainless

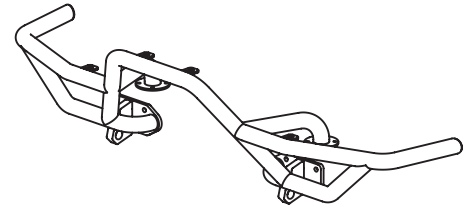

11540.17 - Optional RRC Hoop

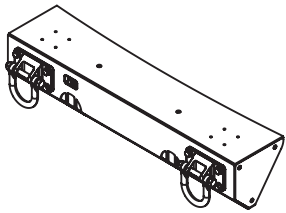

11540.11 - Non-winch Center Section

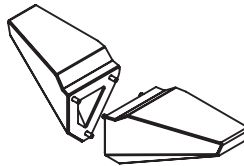

11540.12 - Optional Bumper Ends



11540.17 - Optional Stainless D-Rings

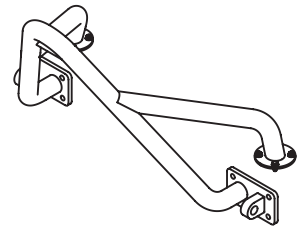

11540.13 - Optional Stinger