



11540.10; 11540.11; 11540.71

07+ Jeep® JK Wrangler XHD Modular Front Bumper (Winch and Non-Winch)

Components:

- | | | | |
|--------------------------|-----|-----------------------|------|
| 1. Bumper Center Section | (1) | 5. M12 X 60 Bolt | (8) |
| 2. Right End Plate | (1) | 6. M12 Washer | (22) |
| 3. Left End Plate | (1) | 7. M12 Lock Nut | (14) |
| 4. D-Ring | (2) | 8. Sheet Metal Screws | (8) |

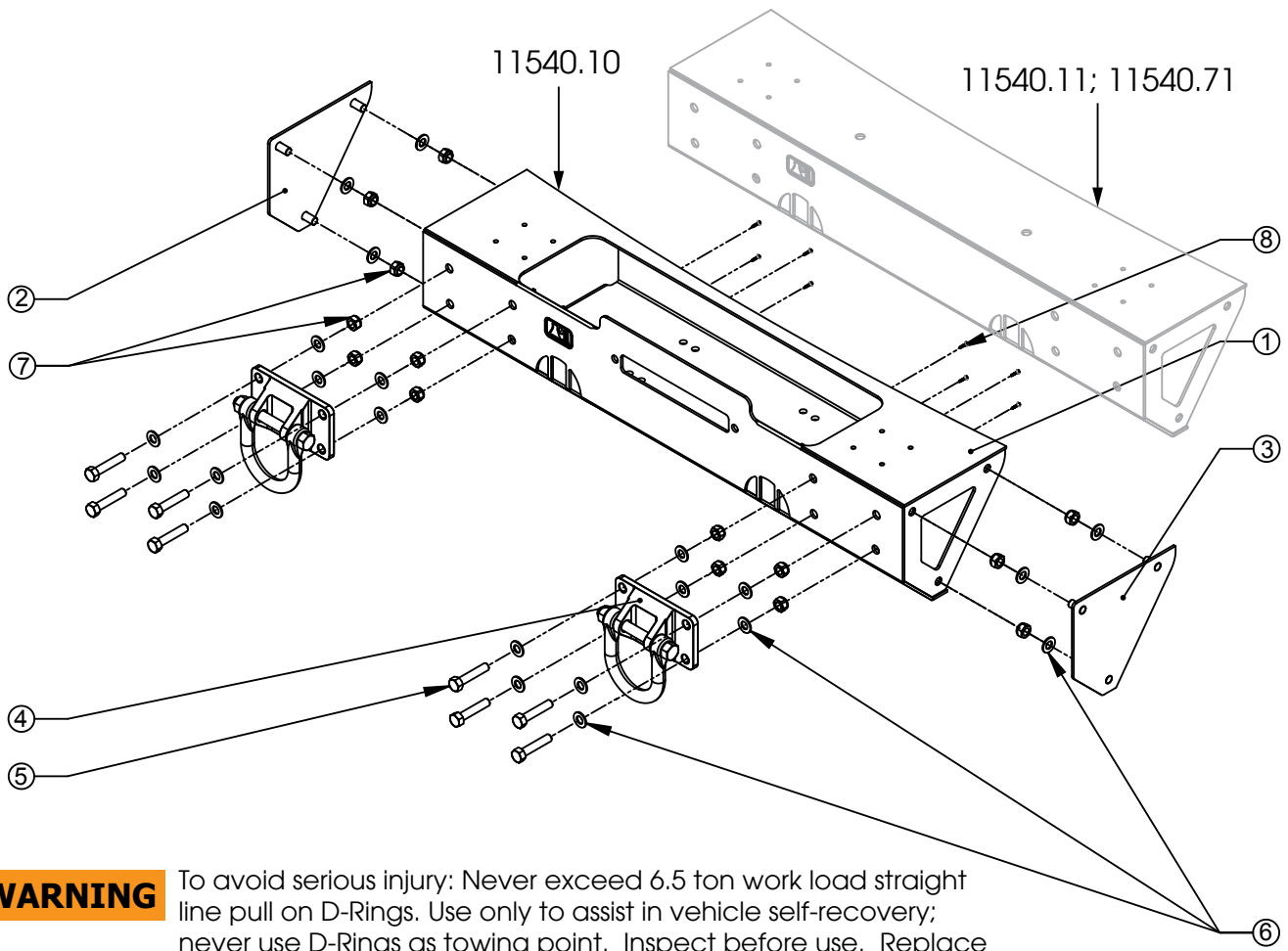

WARNING

To avoid serious injury: Never exceed 6.5 ton work load straight line pull on D-Rings. Use only to assist in vehicle self-recovery; never use D-Rings as towing point. Inspect before use. Replace if damaged or distorted.

Read all instructions thoroughly before installation.

07+ Jeep® JK Wrangler XHD Modular Front Bumper (Winch and Non-Winch)

1. Disconnect fog lights by twisting plug in the rear of fog lights. For newer model Jeeps, squeeze and pull plug to disconnect fog lights.
2. Remove original bumper.
3. Install original fog lights into Center Section from the back. Use the (8) Sheet Metal Screws to secure fog lights.

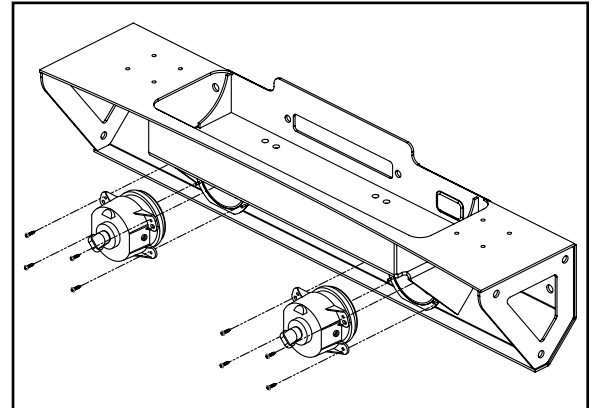

5. Install bumper ends using (3) 12mm washers and (3) 12mm lock nuts per side. Once all nuts have been started tighten nuts securely.

Note: if installing optional ends, such as Stubby Ends (11540.23), High Clearance Ends (11540.24), etc., substitute them for End Plates shown.

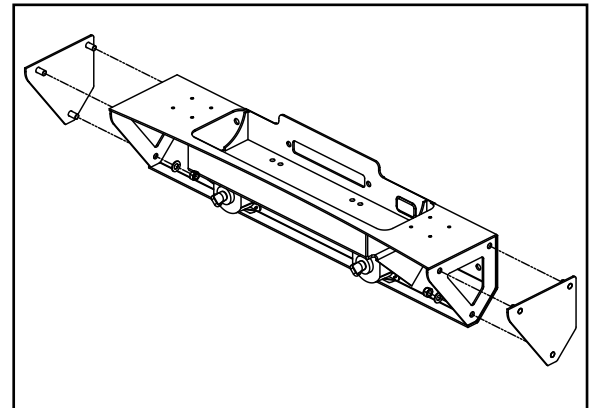

FOR 11540.10 ONLY

6. Install Fairlead (not included) to Center Section.

Note: bolts for Fairlead should pass from inside winch cavity, with nuts being installed on outside of Center Section.

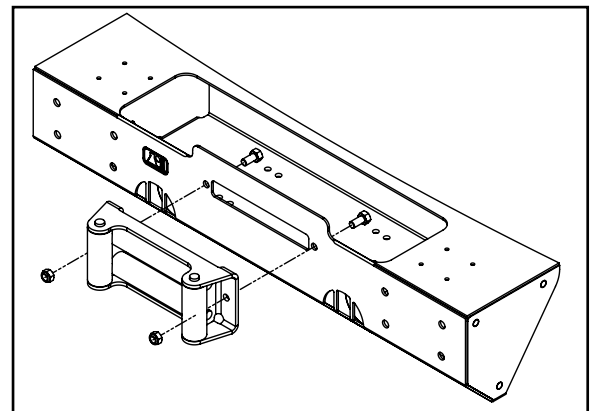

07+ Jeep® JK Wrangler XHD Modular Front Bumper (Winch and Non-Winch)

FOR 11540.10 ONLY

7. Different winches may require different mounting holes to be used (see image to the right for a general guide). For the Warn® Powerplant Winch spacers will be needed (part number: 11540.15).

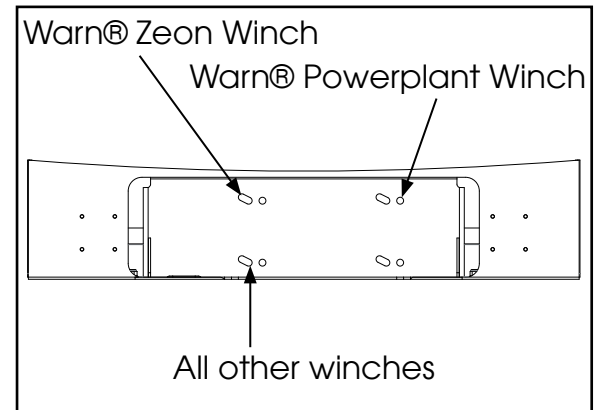

FOR 11540.10 ONLY

8. Prepare winch and vehicle for installation as specified in winch installation instructions. Align mounting holes in bumper with winch mounting holes. It may be helpful to thread winch cable through fairlead before bolting in place. Tighten bolts securely.

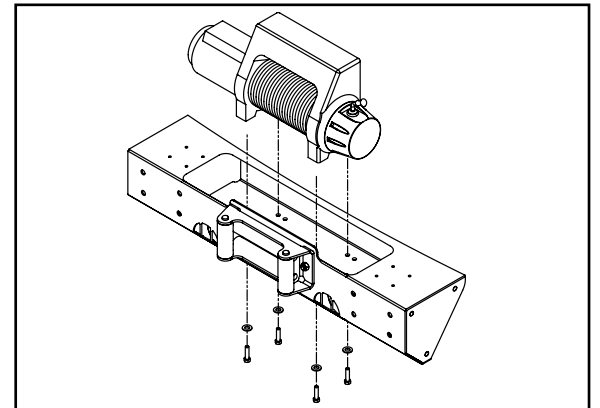

9. Place center section of bumper onto the frame rails and then install the 12 mm bolts (8), 12 mm washer (16), D-Rings (2), and 12 mm Lock Nuts. Do not tighten any fasteners yet. When installing D-Rings, note that the top holes are further apart than the bottom holes.

Note: if installing front mounted accessories such as a Stinger (11540.13), or Double X Striker (11540.25), etc. D-Rings will not be used. See instructions for those products at this point in installation.

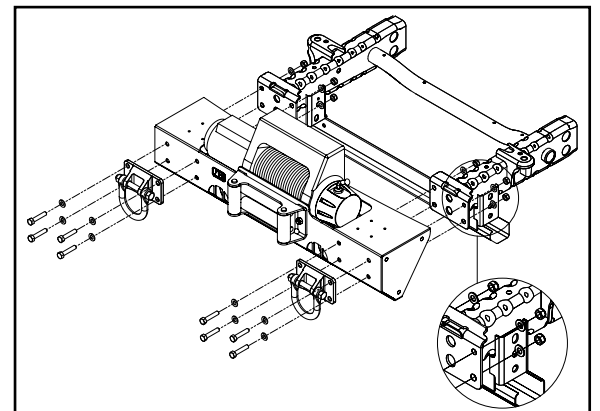



11540.10; 11540.11; 11540.71

12+ Jeep® JK Wrangler XHD Modular Front Bumper (Winch and Non-Winch)

VACUUM PUMP RELOCATION FOR WINCH BUMPER (11540.10)

NOTICE: This section applies only to 2012 and newer JK Wranglers.

Contents:

1. "L" Relocation Bracket	(1)	4. M6 Flat Washer	(7)
2. "Z" Relocation Bracket	(2)	5. M6 Nylock Nut	(3)
3. M6-1.0x30 Hex Head Bolt	(3)		

1. Remove factory bumper and unplug fog lights. Unbolt and remove factory vacuum pump. Save factory M6 nuts, they will be reused later.

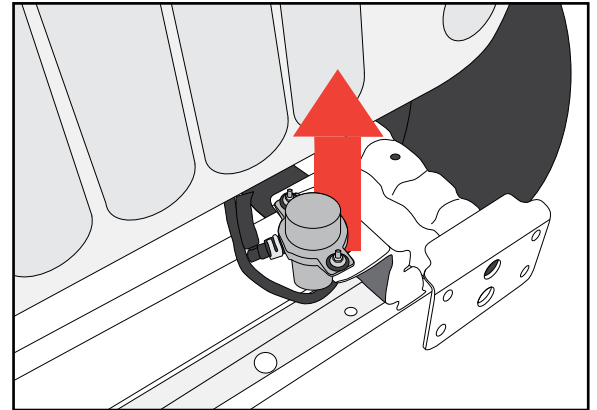

2. Remove front tab from mounting bracket. Cut should be made 2 inches from the end.

3. Spray exposed metal with rust-protecting black spray paint.

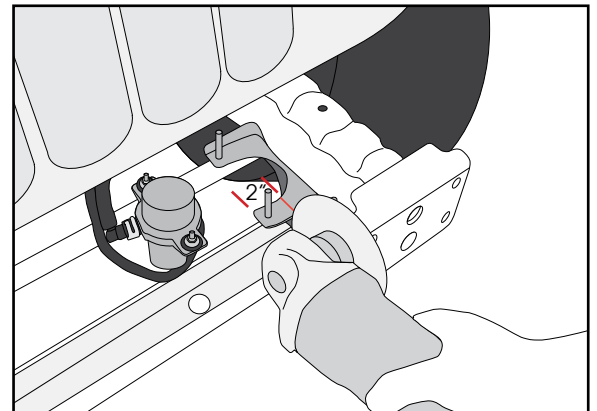

12+ Jeep® JK Wrangler XHD Modular Front Bumper (Winch and Non-Winch)

4. Disconnect hose retainer clips, and remove zip ties holding air lines together to allow for easier movement of air lines.

5. Attach shorter end of "Z" bracket to rear factory mounting stud using factory nut removed in step #1.

6. Bolt pump to "Z" bracket using M6 hex bolt, washers, and Nylock nut. Rotate pump so that it sits inside lower cross member.

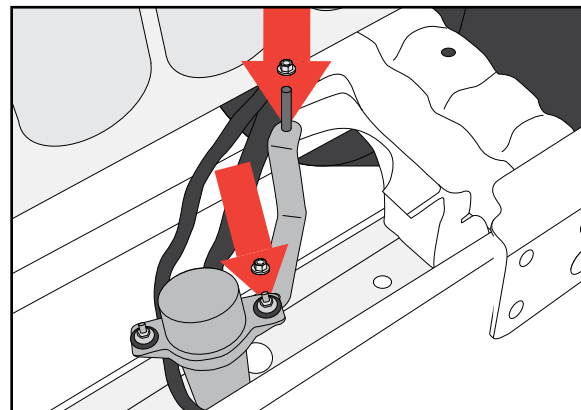

7. Attach short side of "L" bracket to pump using M6 hex bolt, washer, and Nylock nut.

8. With pump centered, mark mounting hole on cross member.

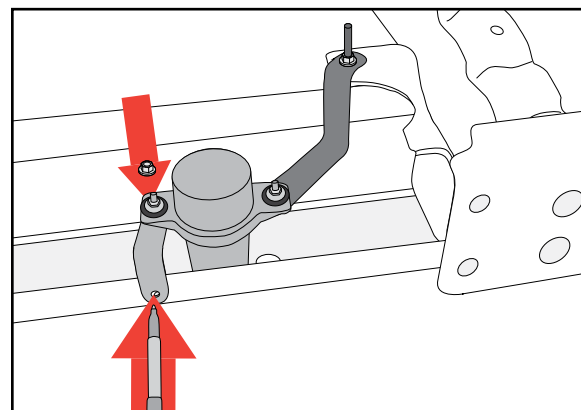

9. Drill mounting hole in cross member with 1/4" drill bit.

10. Spray exposed metal with rust-protecting black spray paint.

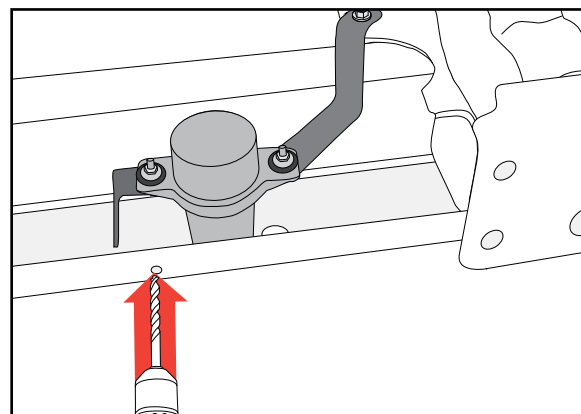



11540.10; 11540.11; 11540.71

12+ Jeep® JK Wrangler XHD Modular Front Bumper (Winch and Non-Winch)

11. Secure "L" bracket to outside of lower cross member using M6 hex bolt, washer, and Nylock nut.

12. Inspect all air and wire lines for contact with frame. If needed, zip ties can be used to reposition lines.

13. Install XHD Bumper Base following previous instructions in this manual. Note: reconnect fog lights before attaching D-Rings and Bumper Base to frame.

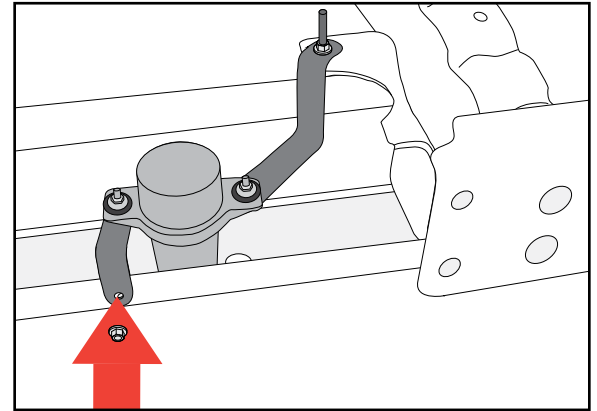

Ask your retailer about additional accessories for your Modular XHD Bumper system!

11540.12 - Standard Bumper Ends, Black
11540.19 - Standard Bumper Ends, Stainless Steel

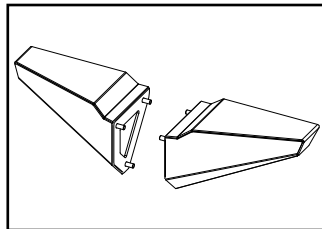

11540.13 - Stinger, Black

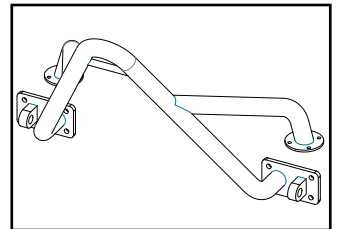

11540.22 - Storage Ends, Black

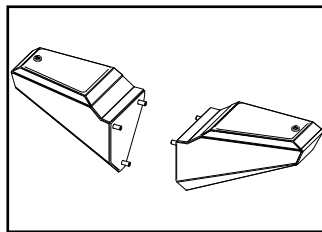

11540.14 - Hoop Over-Rider, Black
11540.16 - Hoop Over-Rider, Stainless Steel

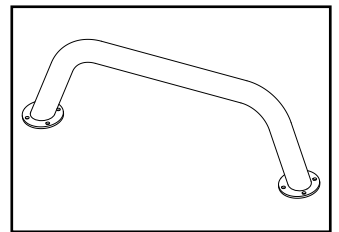

11540.23 - Stubby Ends, Black

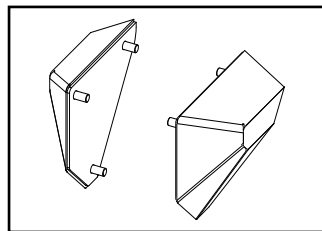

11540.18 - RRC Mount

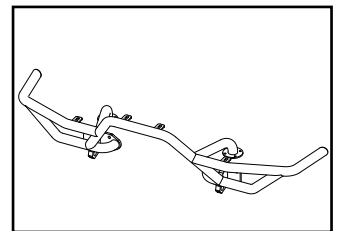

11540.24 - High Clearance Ends, Black

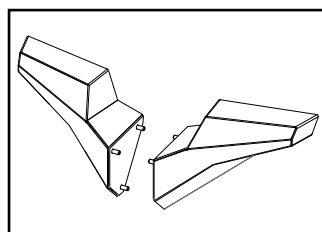

11540.25 - Double X Striker

