

Locking Hood Catch; JK, JL & JT

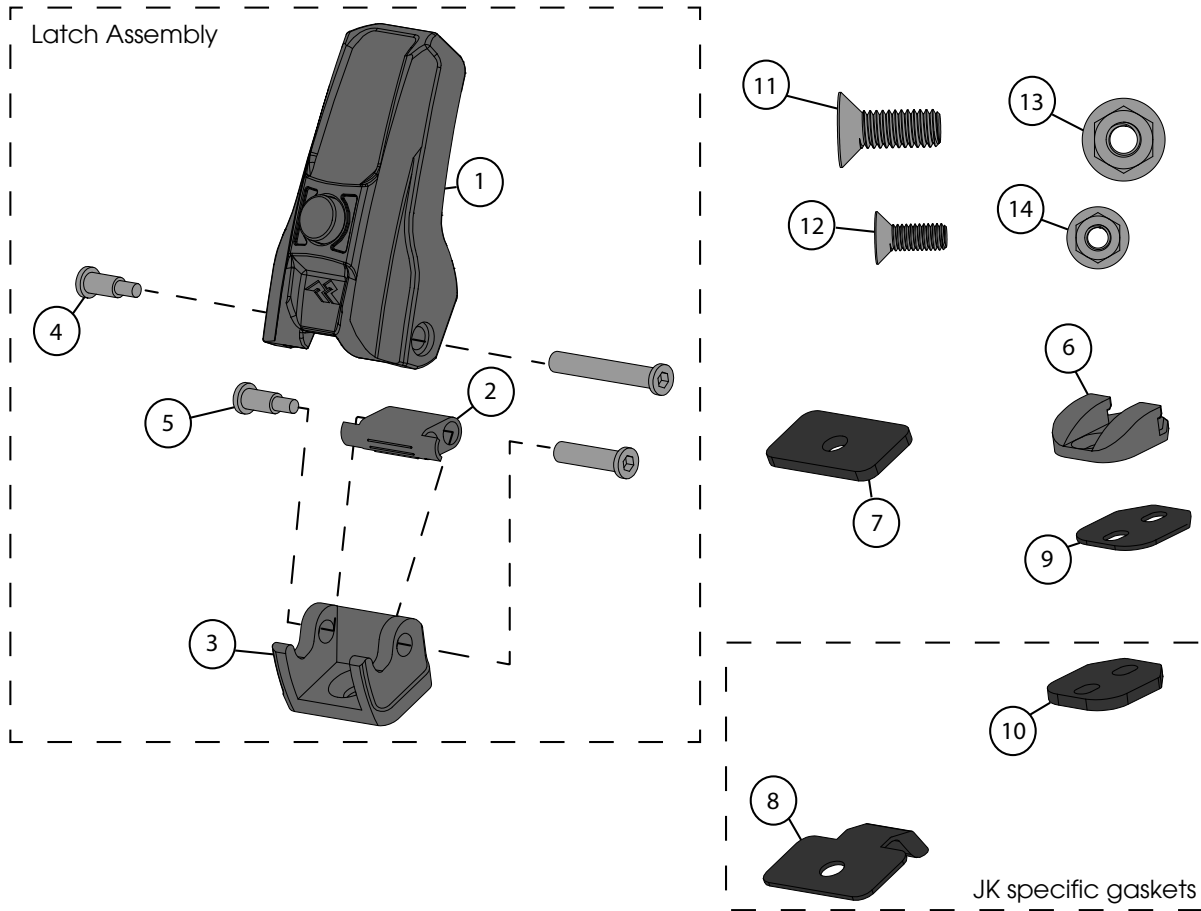

Components

1. Locking Latch	(2)	8. JK Fender Gasket	(2)
2. Pivot	(2)	9. JL Hood Gasket	(2)
3. Pivot Base	(2)	10. JK Hood Gasket	(2)
4. Long Binding Post	(2)	11. M8 Flat Head Bolt	(2)
5. Short Binding Post	(2)	12. M6 Flat Head Bolt	(4)
6. Hood Mount	(2)	13. M8 Nut	(2)
7. JL Fender Gasket	(2)	14. M6 Nut	(4)

Locking Hood Catch; JK, JL & JT

1. Remove the factory hood catch.

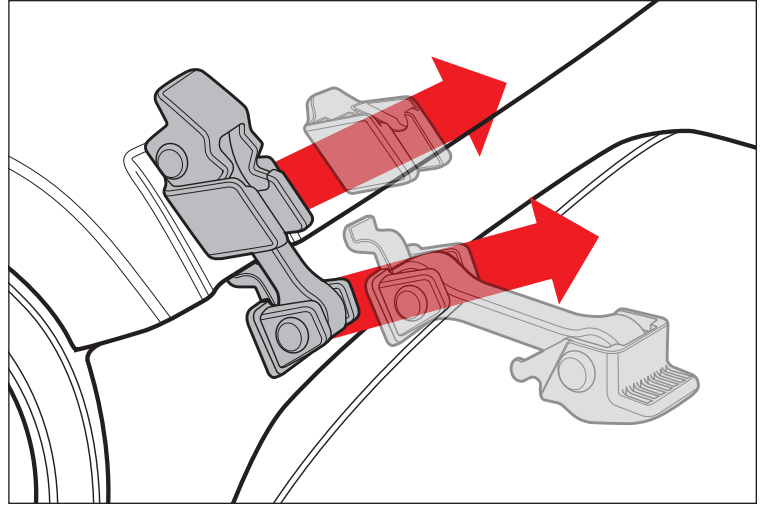

2. Using supplied M8 flat head bolt and nut, loosely attach locking latch assembly and fender gasket to OE fender.

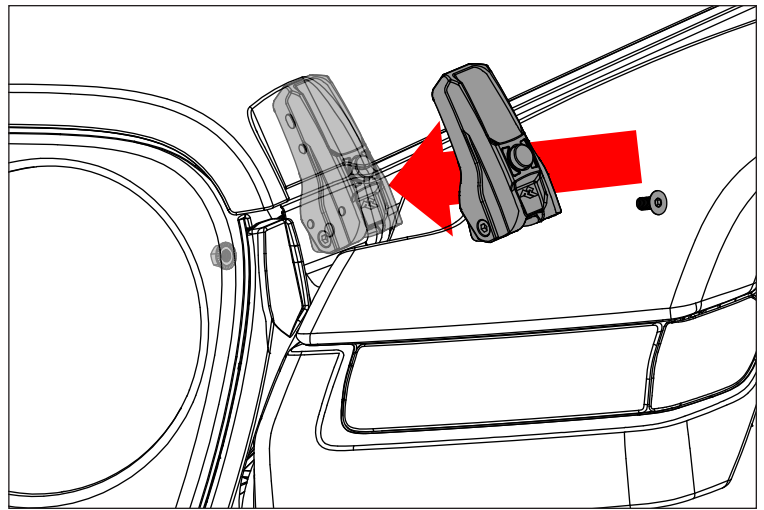

NOTICE Make sure to use the correct gaskets.

3. Using supplied M6 flat head bolt and nut, loosely attach hood mount and hood gasket to the vehicle.

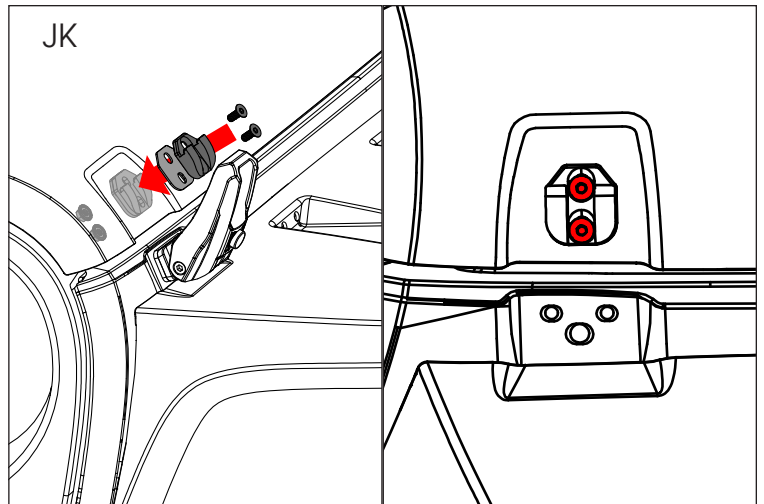
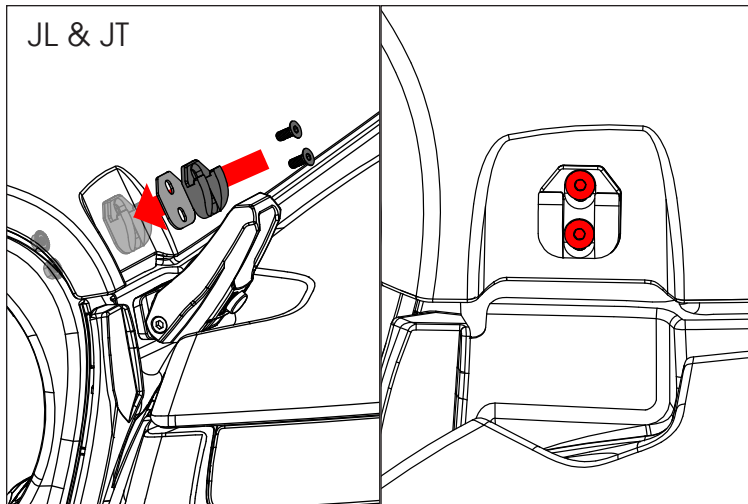

Locking Hood Catch; JK, JL & JT

4. Secure the locking latch to the hood mount. Tighten M8 flat head bolt.

5. Release locking latch. Tighten M6 flat head bolt.

NOTICE The Pivot Base and Hood Mount may need to be moved up or down to ensure smooth function.

