

Jeep® JK Wrangler Modular HD Front Bumper Stinger

Contents:

1. Stinger (1)

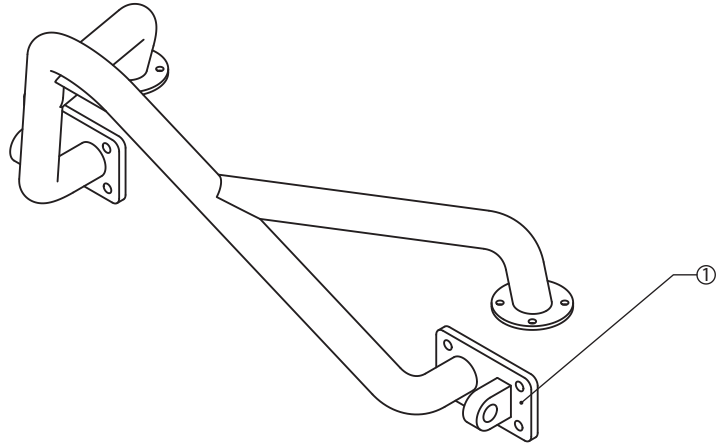

1. If installing as part of a new installation, place center section of bumper onto frame rails, but do not yet attach. If stinger is being added to an existing installation, remove existing Hoop and D-Rings from center section. Center section should be sitting on the frame rails, but not attached (Figure 1a). Place Stinger over center section (Figure 1b) and align 8 holes on top and 8 holes on front (Figure 1c).

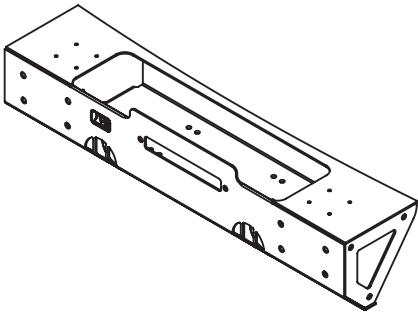

Figure 1a

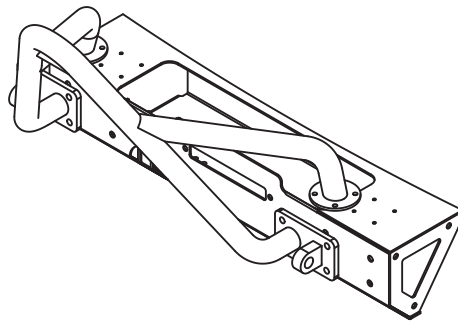

Figure 1b

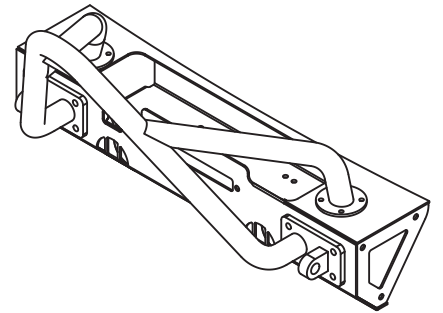

Figure 1c

2. Install 8 top bolts (provided with center section) through the stinger and into the center section (Figure 2a). Do not tighten bolts yet. Install 8 front bolts (provided with center section) through the stinger and into the center section (Figure 2b).

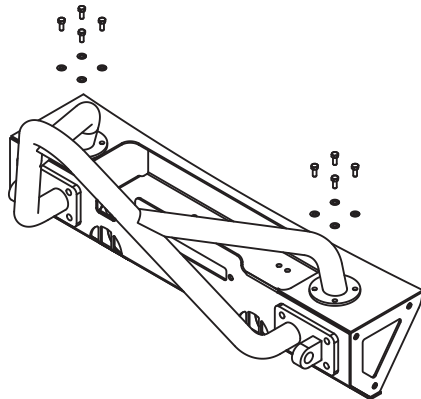

Figure 2a

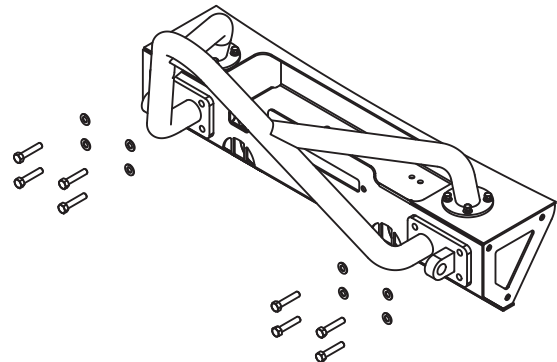
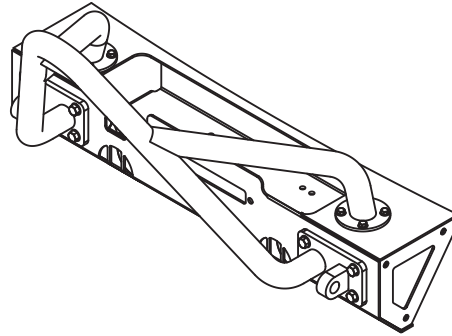
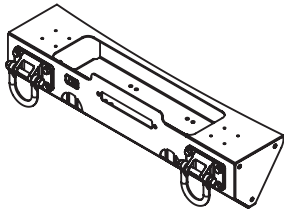

Figure 2b

3. Once all 16 bolts have been started, tighten the front 8 bolts, followed by the 8 top bolts. Installation is now complete! Note: When used for vehicle recovery, only the D-Ring mounts at the base of the Stinger are to be used. Stinger bar is not to be used for towing or vehicle recovery.



Congratulations on the purchase and installation of a quality Rugged Ridge product! Ask your retailer about the following additional accessories to the JK Modular HD Bumper:



11540.10 - Winch Center Section

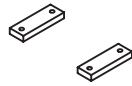

11540.15 - Optional Spacers for use with Warn® Powerplant Winch

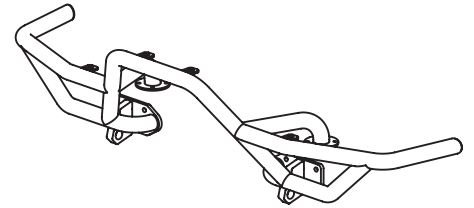

11540.17 - Optional RRC Hoop

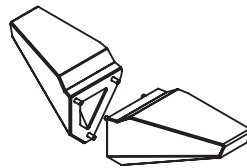

11540.12 - Optional Bumper Ends

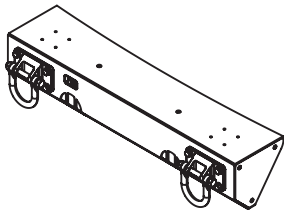

11540.11 - Non-winch Center Section

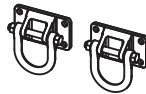

11540.17 - Optional Stainless D-Rings

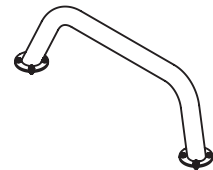

11540.14 - Optional Hoop - Black
11540.16 - Optional Hoop - Stainless