

2015 Mustang Fastback Rear Spoiler

Installation Instructions

P/N: 421883 • 421884 • 421885 • 421886
421887 • 421888 • 421889 • 421890
421891 • 421892 • 421893



ROUSH[®]
PERFORMANCE

2015 Mustang Fastback Rear Spoiler

Installation Instructions

P/N: 421883 (R1315-SPOILERXX) Primed
421884 (R1315-SPOILERCY) - Competition Orange
421885 (R1315-SPOILERH3) - Triple Yellow
421886 (R1315-SPOILERHN) - Guard Metallic
421887 (R1315-SPOILERJ4) - Deep Impact Blue
421888 (R1315-SPOILERJ7) - Magnetic
421889 (R1315-SPOILERPQ) - Race Red
421890 (R1315-SPOILERRR) - Ruby Red
421891 (R1315-SPOILERUA) - Black
421892 (R1315-SPOILERUX) - Ingot Silver
421893 (R1315-SPOILERYZ) - Oxford White

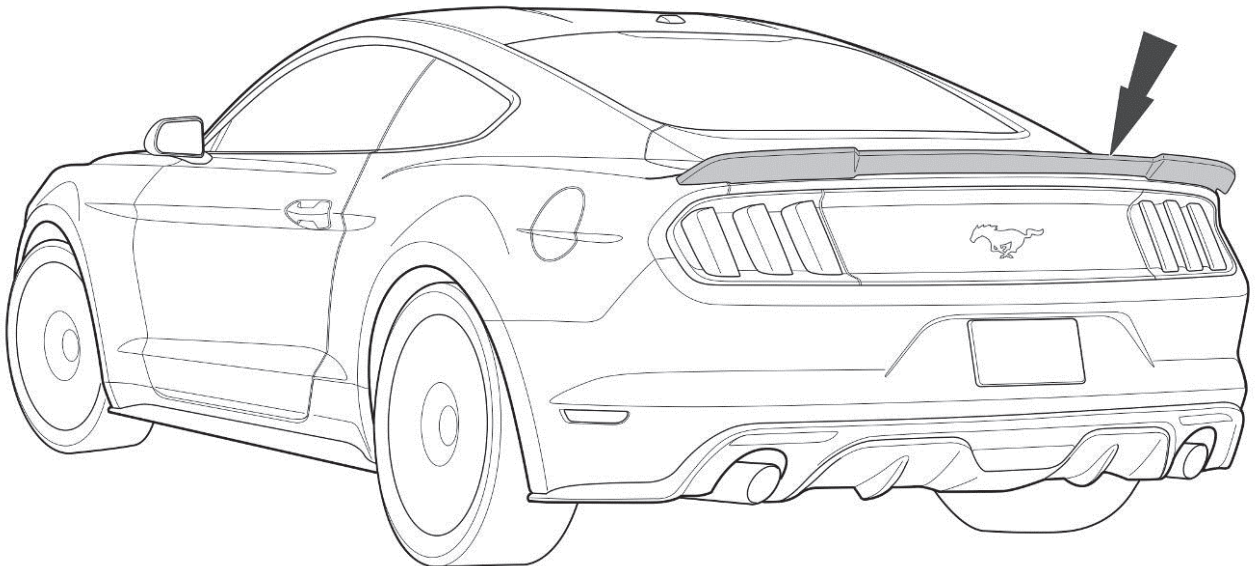

Application: 2015+ Ford Mustang Fastback Only (Does Not Fit Convertible Decklid)

Important Note:

Before installing your ROUSH Performance Product(s), read through the entire installation procedure and check to make sure all items are present.

Note: The ROUSH spoiler is not recommended to be used as replacement on a vehicle equipped from the factory with a spoiler. There will be exposed holes in the decklid if the factory spoiler is removed and this spoiler is installed.

TABLE OF CONTENTS

Packing List for 2015 Mustang Fastback Rear Spoiler3
Equipment and Supplies Required.....3
Limit of Liability Statement.....3
Safety Precautions4
Work Safely!4
Rear Spoiler Installation5

PACKING LIST FOR 2015 MUSTANG FASTBACK REAR SPOILER

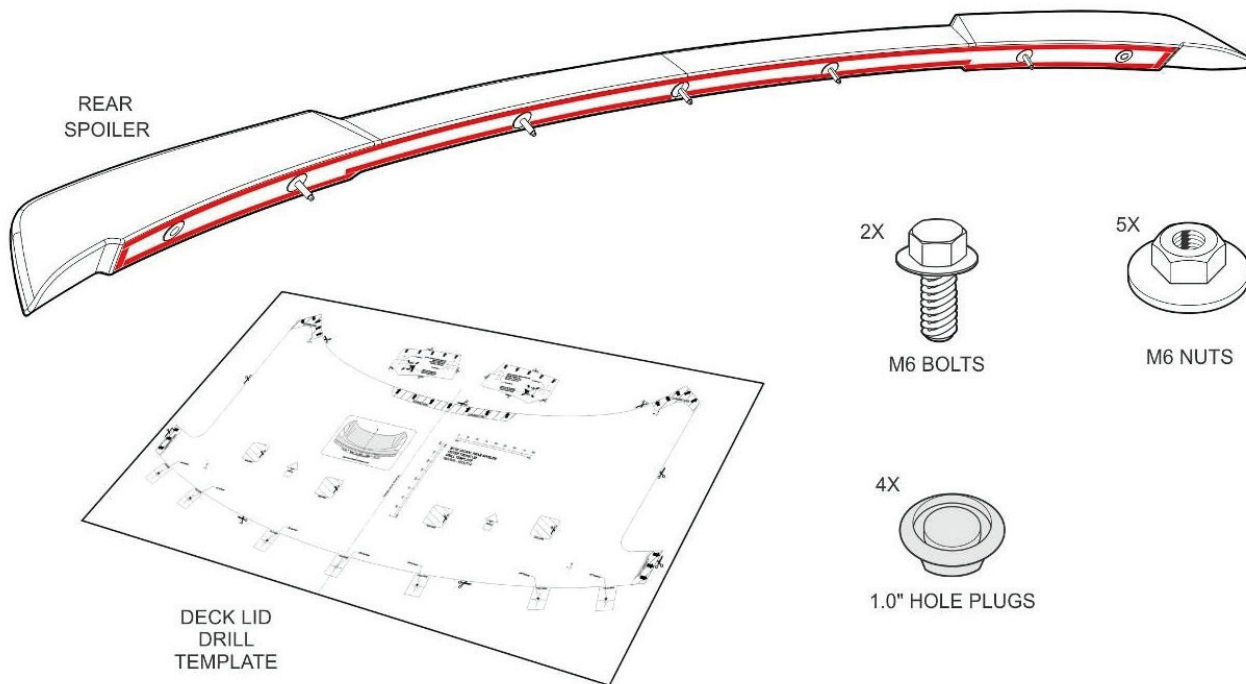

Description	Part Number	Quantity
Rear Spoiler Kit	1315-SPOILERXX	1
Rear Spoiler	1315-6341602	1
M6 Bolts	98093A430	2
M6 Nuts	W704521	5
1.0" Rubber Hole Plugs	BPF-SI-413	4
Drill Template	1315-SPLRTMPL	1

EQUIPMENT AND SUPPLIES REQUIRED

- Isopropyl Alcohol Packets or 50/50 Alcohol/Water Solution
- Drop Cloth
- Scissors
- Masking Tape
- Drill
- Drill Bits: 1/8", 5/16", 3/8", 1.0" Hole Saw,
- Deburr Tool
- Corrosion Inhibitor (Motorcraft PMP-19500-6000 Clear Topcoat recommended)
- 1/4" Drive Ratchet
- 1/4" Extension
- 1/4" 10 mm Socket
- Round File
- Rubber Roller
- Trim Panel Remover

LIMIT OF LIABILITY STATEMENT

The information contained in this publication was accurate and in effect at the time the publication was approved for printing and is subject to change without notice or liability. ROUSH Performance Products (RPP) reserves the right to revise the information presented herein or to discontinue the production of parts described at any time.

SAFETY PRECAUTIONS



CAREFULLY READ THE IMPORTANT SAFETY PRECAUTIONS and WARNINGS BEFORE PROCEEDING WITH THE INSTALLATION!

Appropriate disassembly, assembly methods and procedures are essential to ensure the personal safety of the individual performing the kit installation. Improper installation due to the failure to correctly follow these instructions could cause personal injury or death. Read each step of the installation manual carefully before starting the installation.

- Always wear safety glasses for eye protection.
- Place ignition switch in the OFF position.
- Always apply the parking brake when working on a vehicle.
- Block the front and rear tire surface to prevent unexpected vehicle movement.
- If working with a lift, always consult vehicle manual for correct lifting specifications.
- Operate the engine only in well-ventilated areas to avoid exposure to carbon monoxide.
- Do not smoke or use flammable items near or around the fuel system.
- Use chemicals and cleaners in well-ventilated areas.
- Batteries produce explosive gases, which can cause personal injury. Therefore, do not allow flames, sparks or flammable substances to come near the battery.
- Keeps hands and any other objects away from the radiator fan blades.
- Keep yourself and your clothing away from moving parts when the engine is running.
- Do not wear loose clothing or jewelry that can get caught in rotating parts or scratch surface finishes.
- Allow the engine, cooling system, brakes and exhaust to cool before working on a vehicle.

WORK SAFELY!

Perform this installation on a good clean level surface for maximum safety and with the engine turned off.

PAINTED PART PREPARATION



Unpainted/primed parts purchased from ROUSH require further preparation prior to being painted. Removal of any excess plastic flashing and sanding of the primed parts is required prior to paint application. The primed parts as received should not be painted without further surface preparation.

REAR SPOILER INSTALLATION

1. Make sure the vehicle's sheet metal is clean and dry. The sheet metal should be between 61°-81°F (16°-31°C).
2. Open the trunk lid and remove eleven (11) plastic clips from the liner and the two (2) rubber bump stops (twist off). Remove the inner trunk lid liner and gently pull around the trunk release mechanism. Keep these items to re-install later.

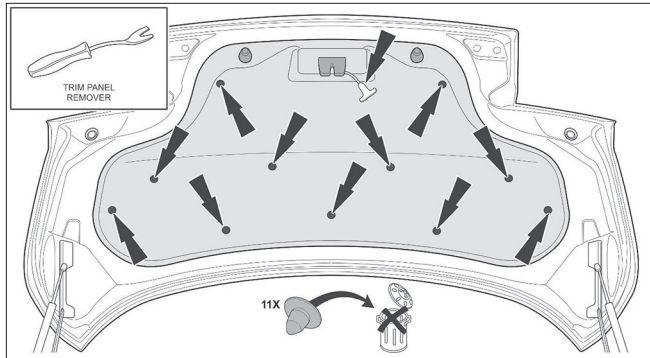

3. Remove and retain the two (2) OE rubber hole plugs, one (1) per side.

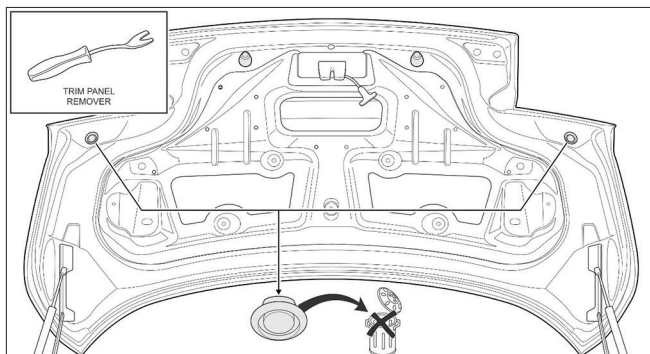

4. Place a large drop cloth into trunk luggage area underneath where you will be drilling the trunk lid.

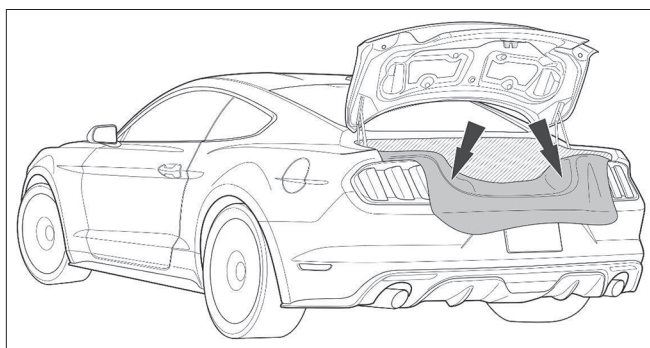

5. Carefully cut out the LH and RH inner drill templates from the larger template sheet (1315-SPLRTMPL).

6. Align the LH and RH inner template and secure to the inner sheet metal with masking tape, as indicated.

Attention: Confirm template is properly centered and aligned before moving onto the next step.

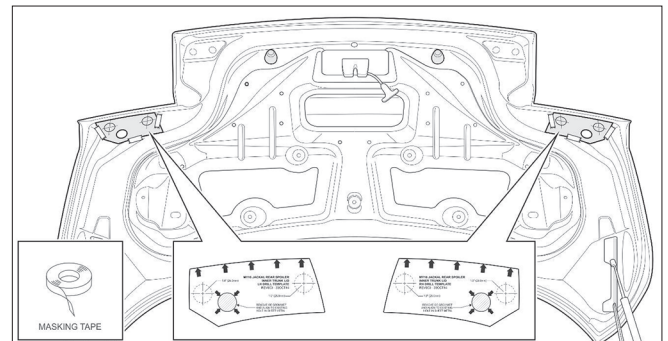

7. Create four (4) access holes in the trunk's inner sheet metal by center punching four (4) hole locations, two (2) per side. Drill each center punched location with a 1/8" drill bit. Enlarge each 1/8" hole with a 1.0" hole saw.

CAUTION

Care should be taken not to damage the outer sheet metal of the vehicle trunk lid.

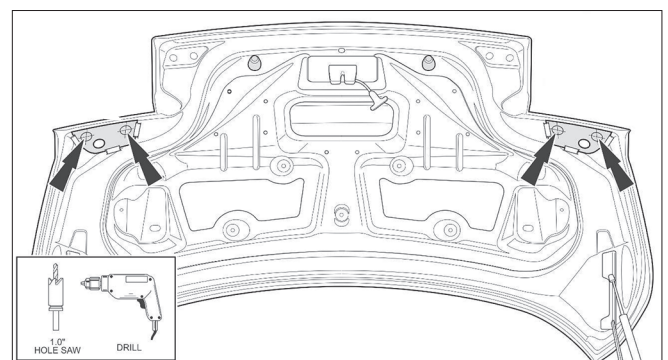

8. Deburr and apply corrosion inhibitor to each of the four (4) 1.0" access holes. Allow to dry.

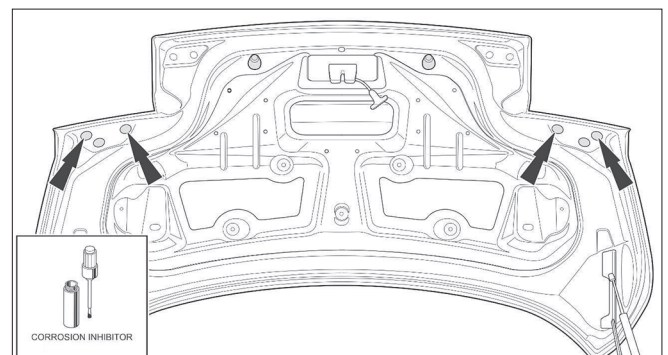

9. Carefully cut out the large outer drill template. Take extra care in the areas indicated with the black arrows. These areas are crucial to the correct alignment of the template.

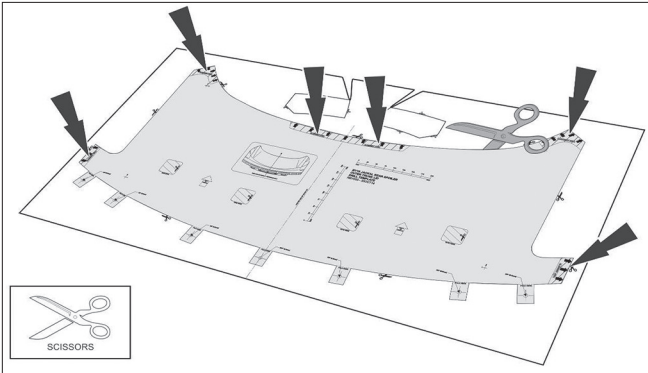

10. Install the trunk lid outer sheet metal drill template. With the trunk lid closed, align the large outer drill template onto the outer sheet metal of the trunk lid as shown. Secure template to trunk lid with masking tape.

Attention: Confirm template is properly centered and aligned before continuing to the next step.

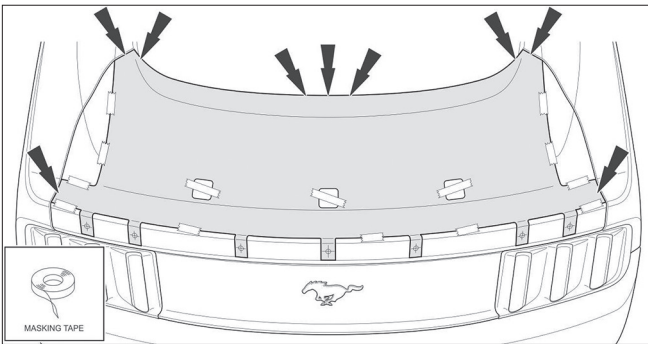

11. Drill seven (7) rear spoiler mounting holes. Center punch the seven (7) hole locations indicated on the template. Drill each center punch location with a 1/8" drill bit. Enlarge each 1/8" hole to the size indicated on the template. Note that the center hole should be enlarged to 5/16" while the other six (6) holes should be enlarged to 3/8".

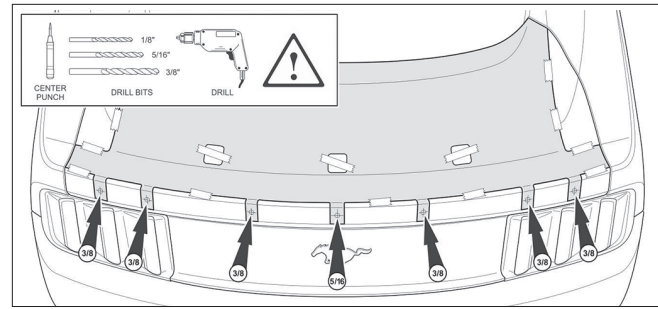

12. Test fit the rear spoiler. Align the five (5) studs on the rear spoiler through the holes drilled into the trunk lid. Secure the rear spoiler to the trunk lid with masking tape.

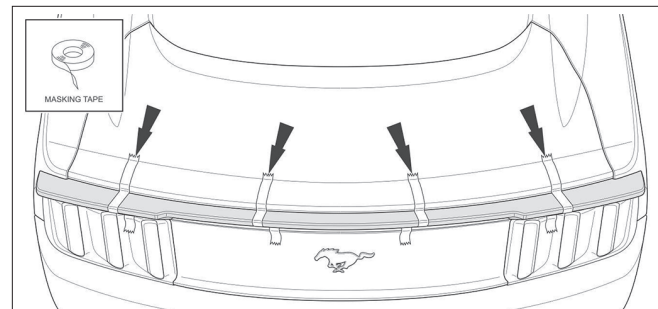

13. Open the trunk lid and inspect each of the seven (7) mounting holes. Confirm that the rear spoiler fasteners are properly aligned with the holes drilled in the trunk lid outer sheet metal.

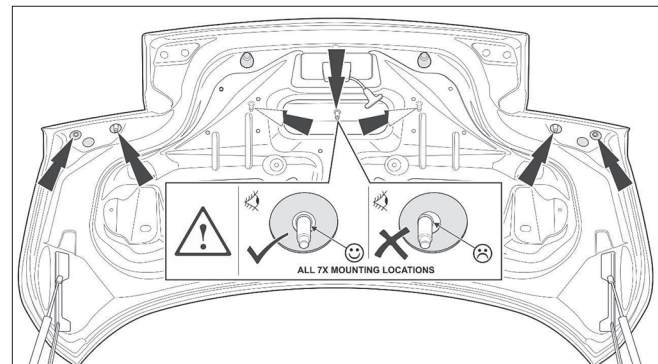

14. If the fasteners and holes are not aligned, remove the rear spoiler and use a round file to adjust the holes in the trunk lid outer sheet metal accordingly.

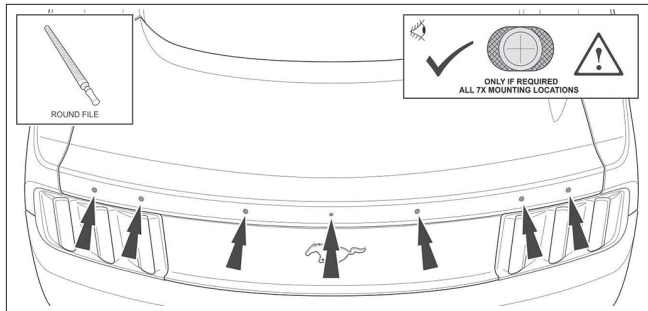

15. Close the trunk lid and remove the rear spoiler.

16. Clean the trunk lid with 50/50 (alcohol/water) solution and allow to dry.

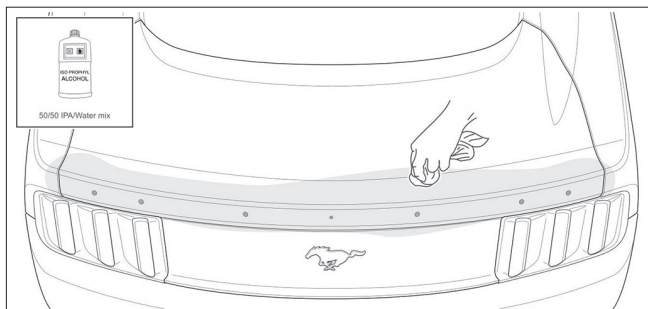

17. Deburr and apply corrosion inhibitor to all the holes drilled in the outer sheet metal. Allow to dry.

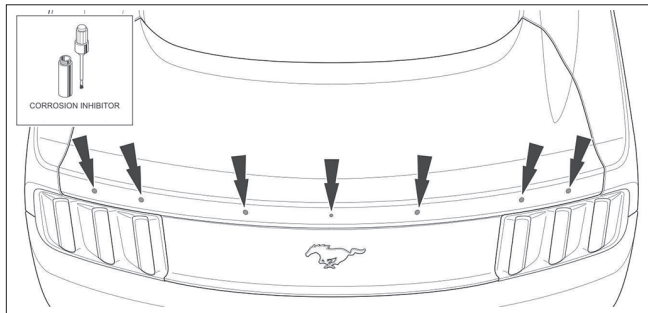

18. Prepare rear spoiler for installation. Peel back 2.0" (50.0 mm) of each tape liner and secure each liner to the outer surface of the rear spoiler using masking tape.

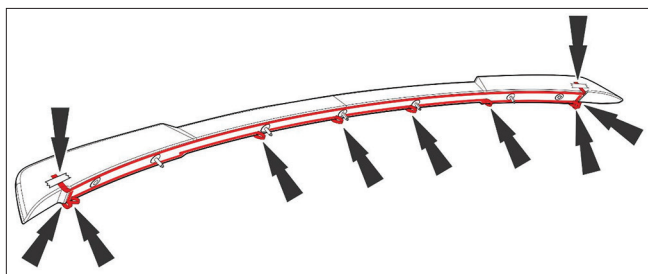

19. Install the rear spoiler through the holes drilled into the trunk lid. Do not allow the exposed double-sided tape to adhere to the sheet metal until you have confirmed the spoiler is centered, then push down.

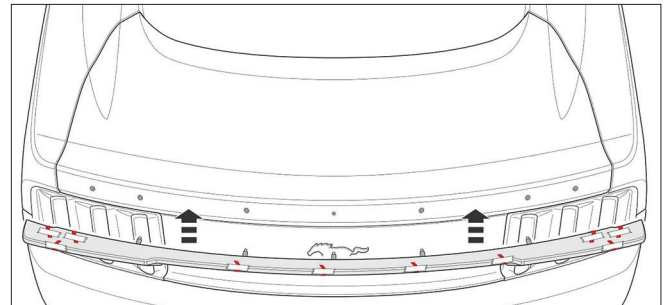

20. Remove all ten (10) tape liners in the direction indicated below.

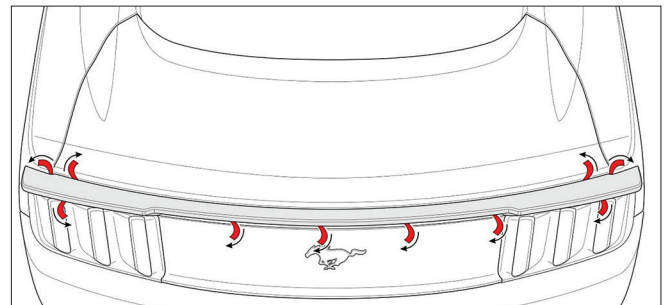

21. Using a rubber roller or the palm of your hand, apply 15 ft-lb of force to the tape area to 'wet-out' the tape. Start from the center of vehicle and work outwards.

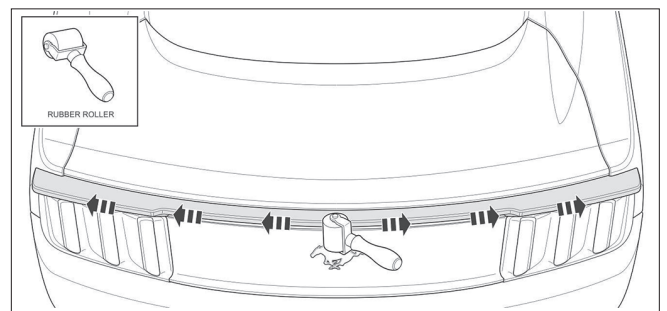

22. Fasten the rear spoiler to the trunk lid. Open the rear trunk lid and install the five (5) M6 nuts and two (2) M6 bolts. Hand tighten only, do not fully tighten. Starting from the center and working outwards to either end, tighten all fasteners to 3.5 ft-lb in the order shown below.

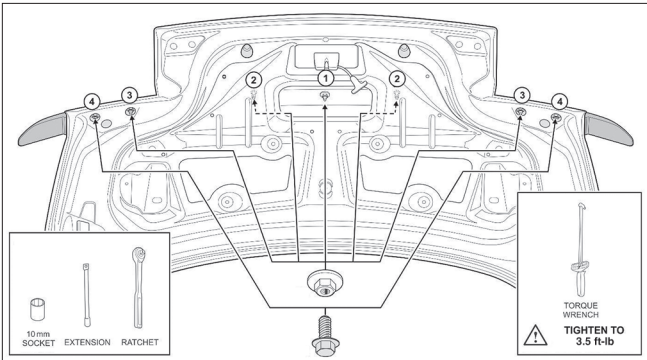

23. Re-install the two (2) OE rubber hole plugs removed in step 3. Install four (4) new 1.0" rubber holes plugs into the access holes drilled in Step 7.

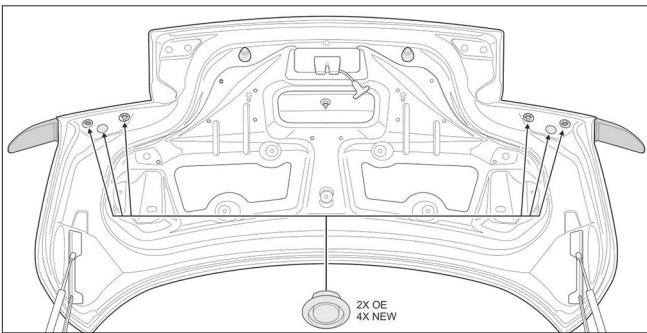

24. Re-install the trunk lid inner liner and clips, rubber bump stops and re-route the rear trunk latch wire.
25. Carefully remove the drop cloth, making sure not to spill any of the metal shavings into the trunk luggage area. Vacuum up any stray metal shavings.

Congratulations!!! You have completed the installation of the ROUSH Performance Rear Spoiler Kit.