



- FOR OFF ROAD USE ONLY -

2011+ Ford F-150 Off Road Exhaust Kit

P/N: 421248 (1111-5E292)

Application: 2011 + Ford F-150 equipped with the following engine options:
3.5L Eco-Boost Engine with automatic transmission.
5.0L 4V Engine with automatic transmission.
6.2L 2V Engine with automatic transmission.

OFF ROAD USE ONLY

Installation Instructions

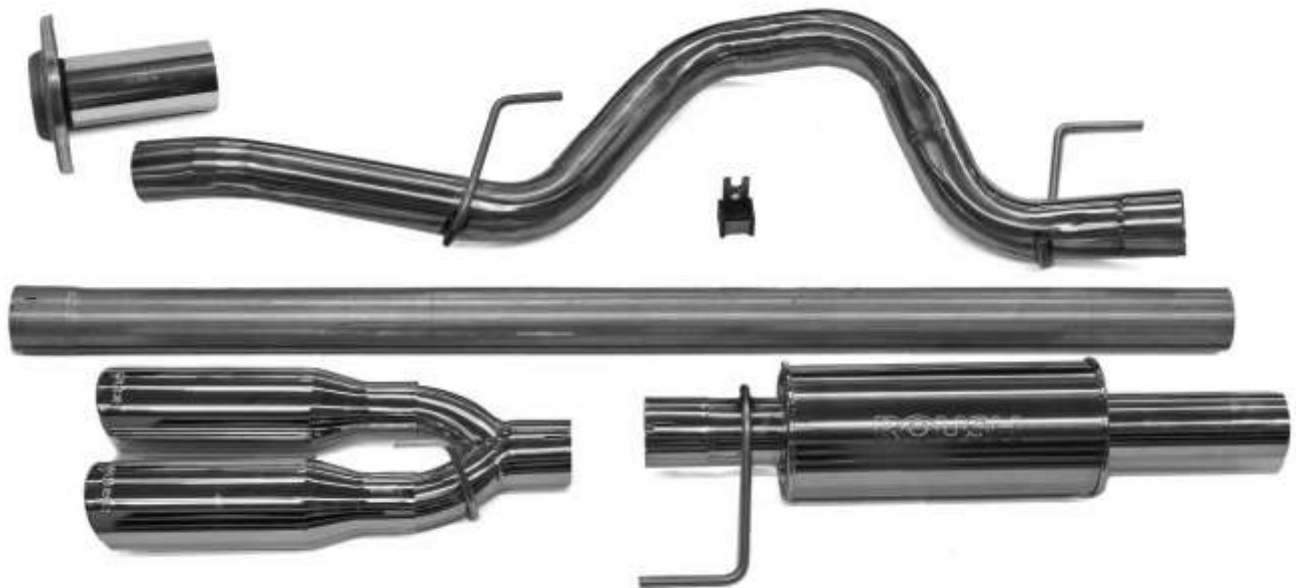



ROUSH[®]
P E R F O R M A N C E

- FOR OFF ROAD USE ONLY -

PACKAGING LIST FOR OFF ROAD EXHAUST KIT #421248

Description	Part Number	Qty
Pipe Asy – Catalyst Pipe Adapter	1111-5G267	1
Pipe Asy - Muffler Inlet	1111-5246	1
Muffler Asy	1111-5230	1
Pipe Asy - Muffler Outlet (Over Axle)	1111-5C262	1
Tail Pipe Asy (Y-Pipe)	1111-5255	1
Tail Pipe Hanger Bracket	1111-5A204	1
Exhaust Tip - Ø 4" w/Roush Logo	1111-5230TIP	2
2.5" Clamp (Tips to Y-Pipe)	R12060014	2
3.0" Clamp (Pipe to Pipe)	R12060012	4
Installation Instructions	1111-5E292IM	1

EQUIPMENT AND SUPPLIES REQUIRED

- Metal Cutting device (Band Saw, Hack Saw, Cut off Wheel)
- Ratchet with Extensions
- Metric Socket Sets (deep recommended)
- Torque Wrench



ROUSH[®]
P E R F O R M A N C E

- FOR OFF ROAD USE ONLY -

LIMIT OF LIABILITY STATEMENT

The information contained in this publication was accurate and in effect at the time the publication was approved for printing and is subject to change without notice or liability. ROUSH Performance Products (RPP) reserves the right to revise the information presented herein or to discontinue the production of parts described at any time.

SAFETY REQUIREMENTS

STOP! READ IMPORTANT SAFETY CAUTIONS AND WARNINGS BEFORE PROCEEDING.

IMPORTANT SAFETY NOTICE

Appropriate disassembly, assembly methods and procedures are essential to ensure the personal safety of the individual performing the kit installation. Improper installation due to the failure to correctly follow these instructions could cause personal injury or death. Read each step of the installation manual carefully before starting the actual installation.

1. Always wear safety glasses for eye protection.
2. Place ignition switch in the OFF position.
3. Always apply the parking brake when working on a vehicle.
4. Chock the front and rear tires to prevent unexpected vehicle movement.
5. If working without a lift, always consult vehicle manual for correct lifting specifications.
6. Operate the engine only in well-ventilated areas to avoid exposure to carbon monoxide.
7. Do not smoke or use flammable items near or around the fuel system.
8. Use chemicals and cleaners in well-ventilated areas.
9. Batteries produce explosive gases, which can cause personal injury. Therefore, do not allow flames, sparks or flammable substances to come near the battery.
10. Keeps hands and any other objects away from the radiator fan blades.
11. Keep yourself and your clothing away from moving parts when the engine is running.
12. Do not wear loose clothing or jewelry that can get caught in rotating parts or scratch surface finishes.
13. Allow the engine, cooling system, brakes and exhaust to cool before working on a vehicle.

WORK SAFELY!

Perform this installation on a good clean level surface for maximum safety and with the engine turned off.



- FOR OFF ROAD USE ONLY -

SECTION A – DISASSEMBLY

The following section will guide you through the disassembly and removal of the stock components. Longer wheelbase trucks will also have an intermediate pipe (not shown) between the factory resonator and the muffler.

1. Remove the two bolts that secure the intermediate pipe and resonator to the catalyst pipe. Set these fasteners aside as they will be re-used.

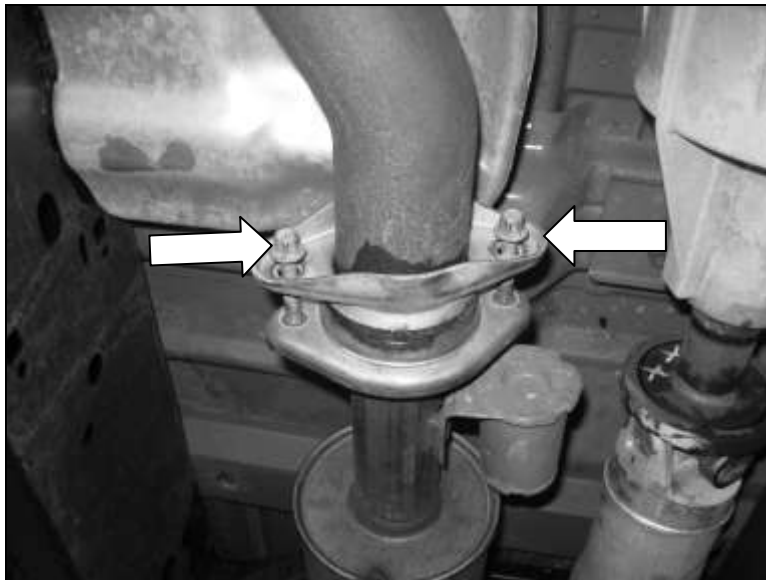

2. Loosen the clamps, which secure the intermediate pipe and resonator to the muffler and tail pipes.

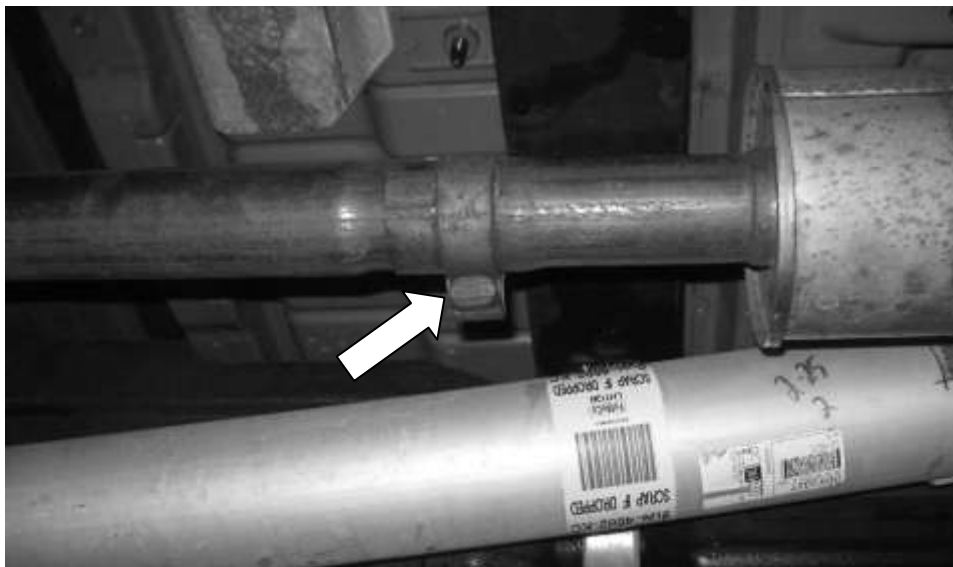



- FOR OFF ROAD USE ONLY -

3. Remove the intermediate pipe and resonator from the vehicle.
4. Slide each of the hangers out of the rubber hangers and remove the factory muffler / tail pipe assembly from the vehicle.

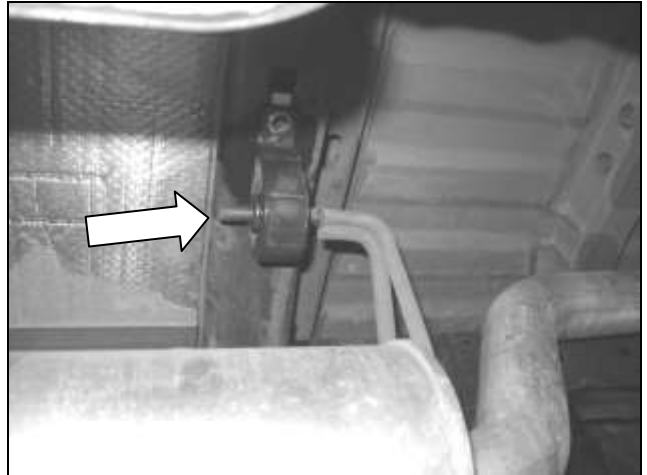



- FOR OFF ROAD USE ONLY -

SECTION B – ASSEMBLY 3.5L & 5.0L

The following section will guide you through the assembly and installation of the ROUSH components on a vehicle equipped with a 3.5L V6 or the 5.0L V8.

1. Loosen the rear spring support bracket bolt so you have a gap of about 7 – 10mm of threads showing.

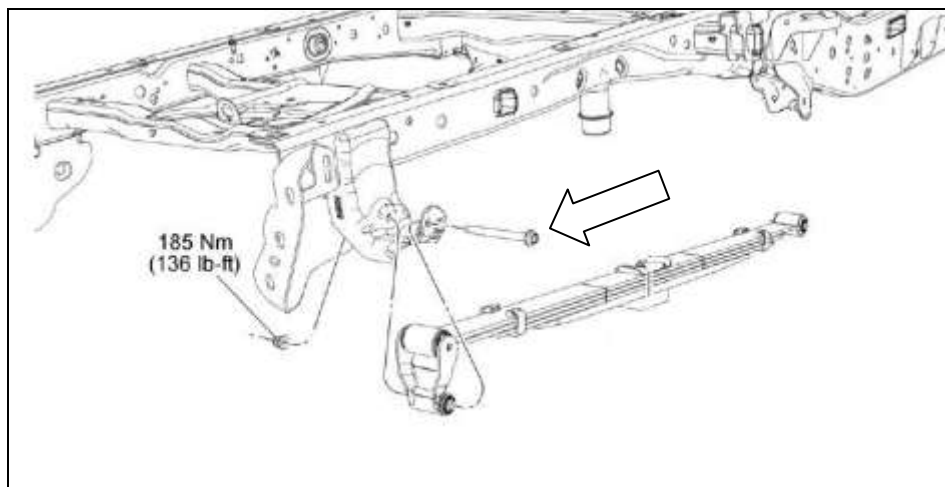



ROUSH[®]
P E R F O R M A N C E

- FOR OFF ROAD USE ONLY -

2. Position the new catalyst pipe adapter flange (1111-5G267) into place against the catalyst pipe and loosely install the two take out fasteners to hold it in place. (6.2L Engine Applications see Section C prior to completing this step)

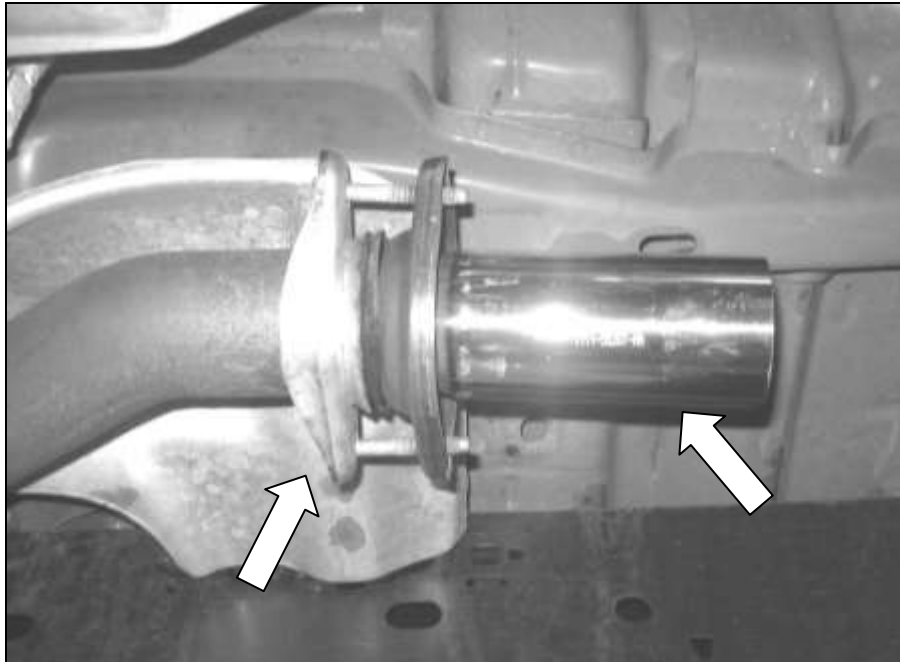

3. Position the new muffler outlet axle pipe (1111-5C262) into position and install the steel hanger brackets into the factory rubber hangers. Orient the pipe such that the flared end faces forward in vehicle.





ROUSH[®]
P E R F O R M A N C E

- FOR OFF ROAD USE ONLY -

4. Insert one (1) 3" clamp (R12060012) over the outlet end of the new muffler assembly (1111-5230) and slide this into the end of the muffler outlet pipe. Install the steel hanger bracket into the factory rubber hanger and position the clamp on the joint and loosely secure.

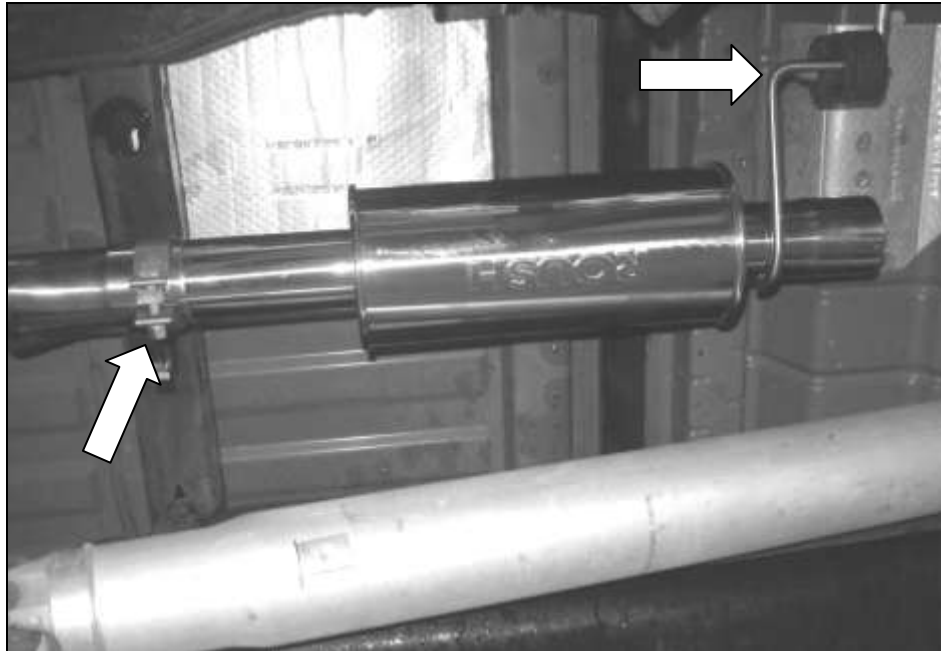

5. Position the intermediate pipe (1111-5246) into the catalyst adapter flange.

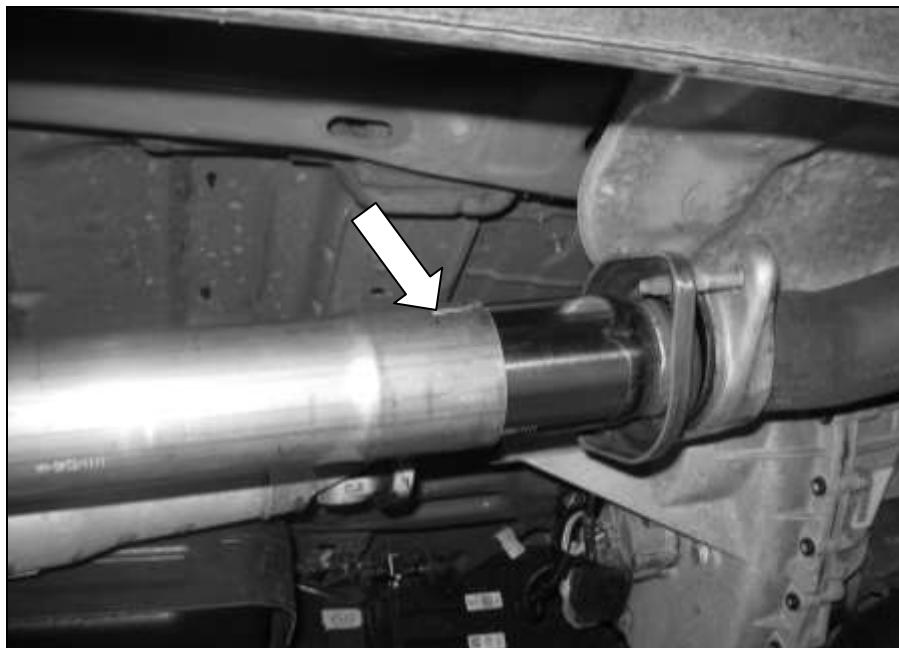



ROUSH[®]
P E R F O R M A N C E

- FOR OFF ROAD USE ONLY -

6. Hold the opposite end of the intermediate pipe up to the muffler inlet and mark the pipe where it needs to be cut, to fit your specific wheelbase vehicle. Be sure to leave enough length for engagement into the muffler inlet pipe.

NOTE: THIS INTERMEDIATE PIPE HAS TO BE CUT TO LENGTH PRIOR TO FINAL INSTALLATION TO FIT YOUR PARTICULAR VEHICLE WHEELBASE

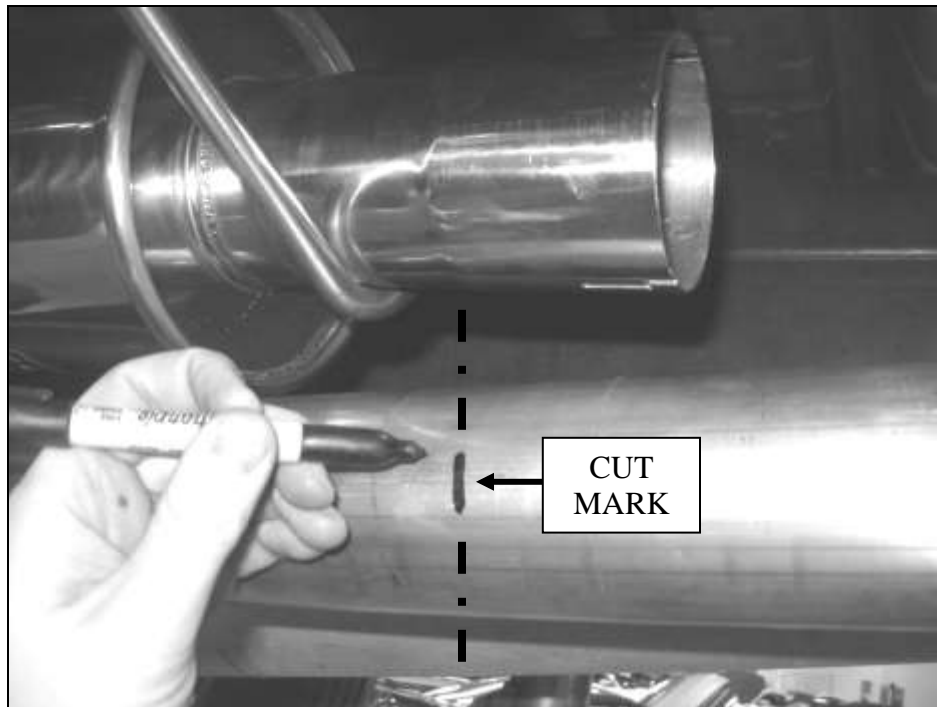

7. Remove the intermediate pipe from the catalyst adapter flange and cut the intermediate pipe at the marked length to fit your wheelbase. Make sure to double check your measurement prior to cutting the material. Remove all sharp edges after cutting.
8. Remove the catalyst pipe adapter flange from the vehicle and insert one (1) 3" clamp (R12060012) over the flared end of the now cut intermediate pipe. Insert the adapter flange inside the intermediate pipe and loosely secure with the clamp.



ROUSH®
P E R F O R M A N C E

- FOR OFF ROAD USE ONLY -

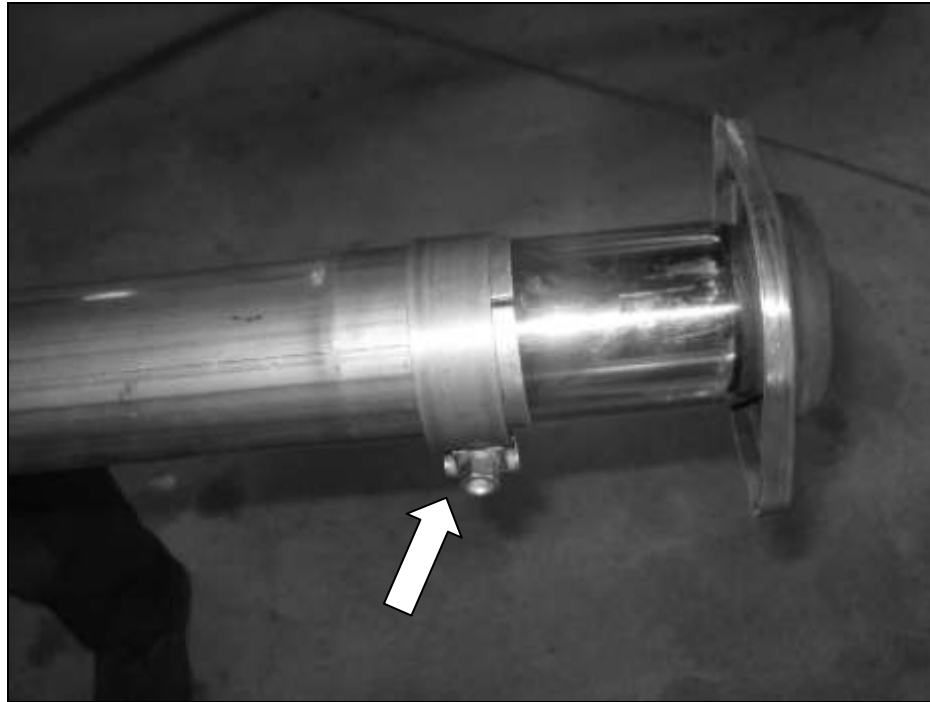

9. Insert one (1) 3" clamp (R12060012) over the end of the intermediate pipe and insert the intermediate pipe into the muffler. Position the clamp on the pipe joint and loosely secure.

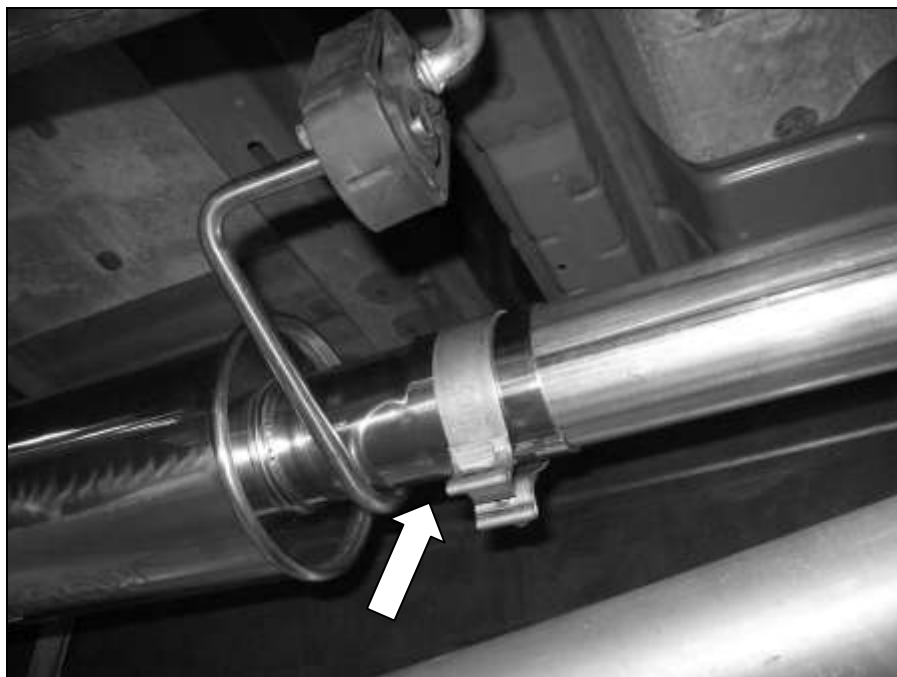



- FOR OFF ROAD USE ONLY -

10. Re-install the pipe assembly to the catalyst flange. Loosely install the two fasteners.



11. Install one (1) 2.5" clamp (R12060014) onto each of the exhaust tips and slide the tips onto the ends of the Y-pipe. Position the clamps on the pipe joints and loosely secure the clamps.

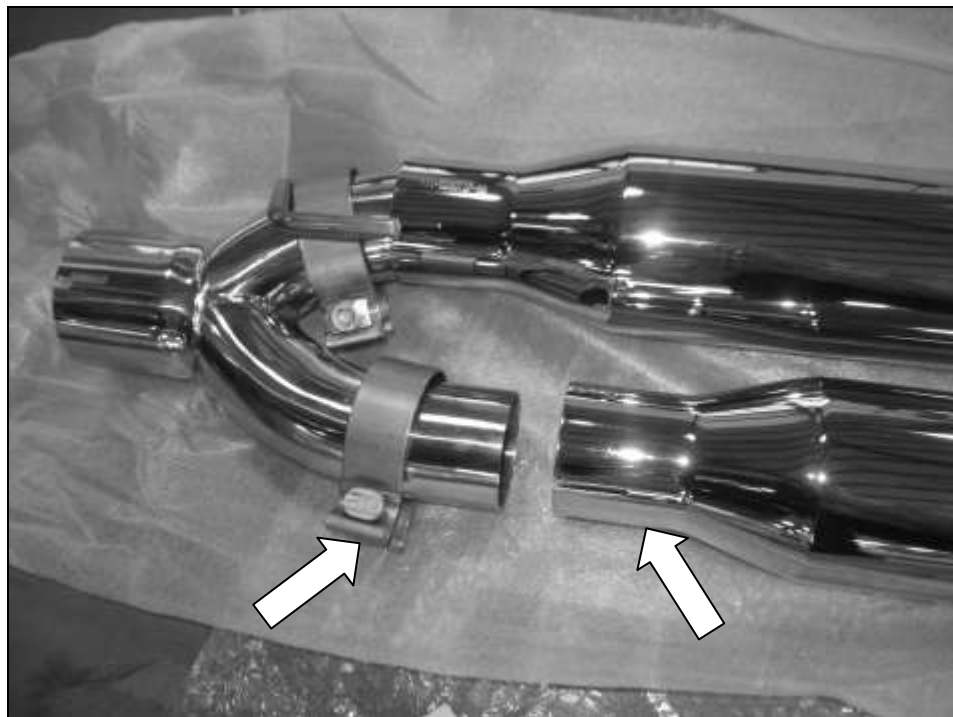



ROUSH[®]
P E R F O R M A N C E

- FOR OFF ROAD USE ONLY -

12. Insert one (1) 3" clamp (R12060012) over the end of the new Y-Pipe Assembly (1111-5255) and slide into position on the end of the muffler outlet pipe.

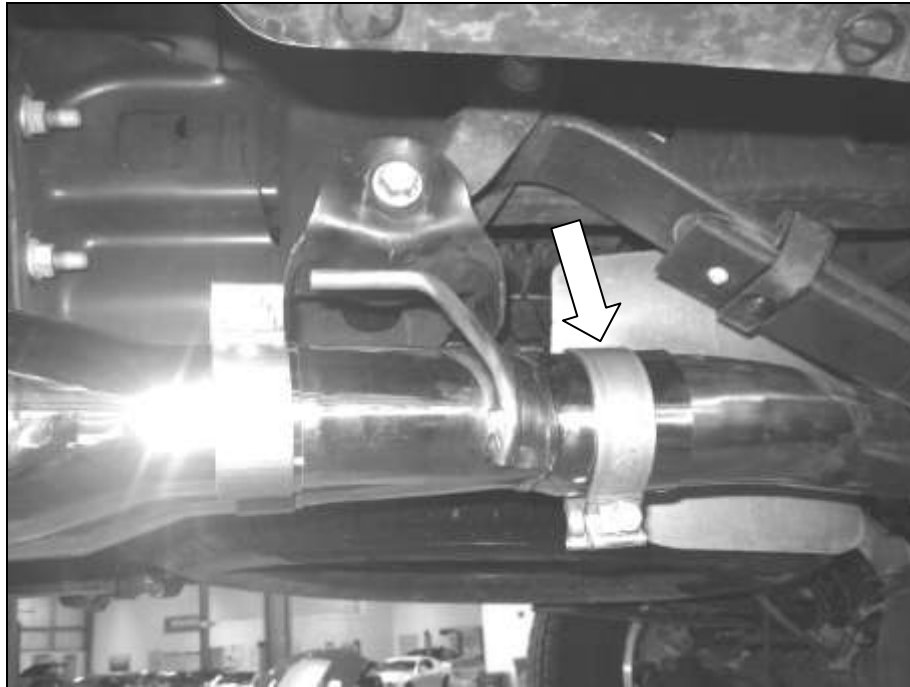

13. Insert the Y-pipe hanger into the hanger bracket. It is important to note the orientation of the bracket as it will hang underneath the suspension bracket.

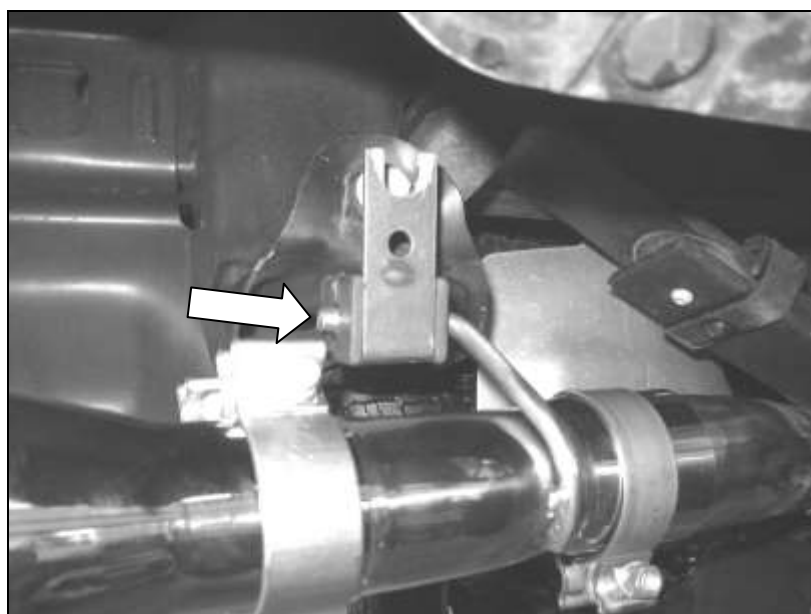



ROUSH[®]
P E R F O R M A N C E

- FOR OFF ROAD USE ONLY -

14. Slide the new rear tailpipe support bracket (1111-5A204) between the head of the bolt and the frame and re-torque the bolt to 185 Nm. Position the bracket as shown.

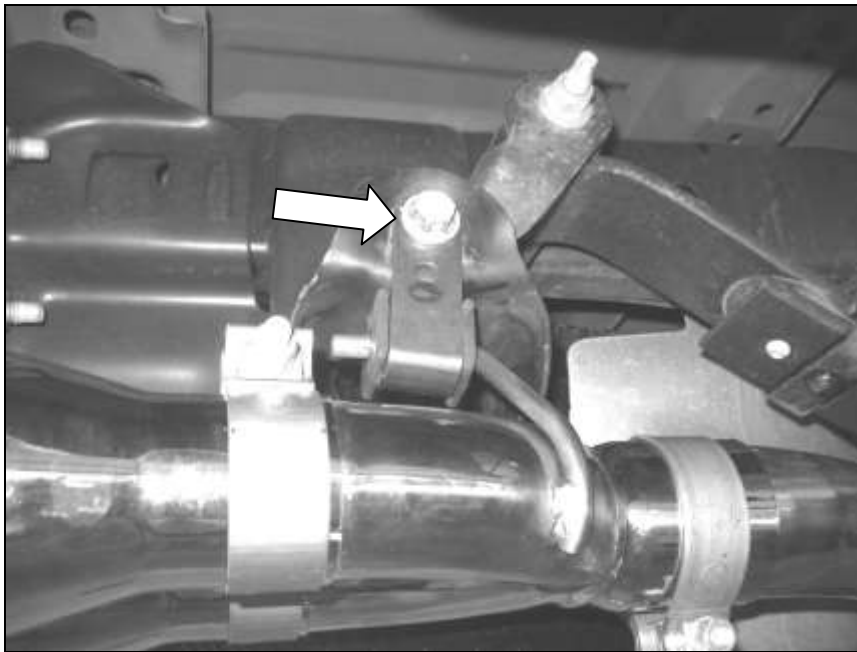

15. With the full system now hanging in the truck, make sure all of the hangers are fully seated and there are no clearance issues with vehicle parts contacting the exhaust system.

Note: On 4x4 trucks the axle pipe needs to be positioned / rotated towards the passenger side frame rail as much as possible. Failure to do this may result in the rear spring contacting the exhaust system ONLY when the suspension is fully relaxed. (ie when vehicle is on a hoist and the suspension has full movement.) To rotate the system, insert a pry bar between the exhaust pipe and axle spring to get the required clearance.



ROUSH[®]
P E R F O R M A N C E

- FOR OFF ROAD USE ONLY -



16. With the system in the desired position, torque all four 3" clamp joints to 47 Nm.
17. Torque the two (2) catalyst adapter bolts (M10 x 1.5) to 44 Nm.



- FOR OFF ROAD USE ONLY -

SECTION C – ASSEMBLY 6.2L

The following additional step needs to be completed prior to starting the installation of the ROUSH components on a vehicle equipped with a 6.2L V8.

1. With the resonator pipe removed from the vehicle as noted in section A, cut the catalyst pipe adapter flange off of your factory resonator pipe. Cut about 12mm (1/2") from the front face of the muffler weld joint. Be sure to remove all sharp edges from the pipe after cutting.

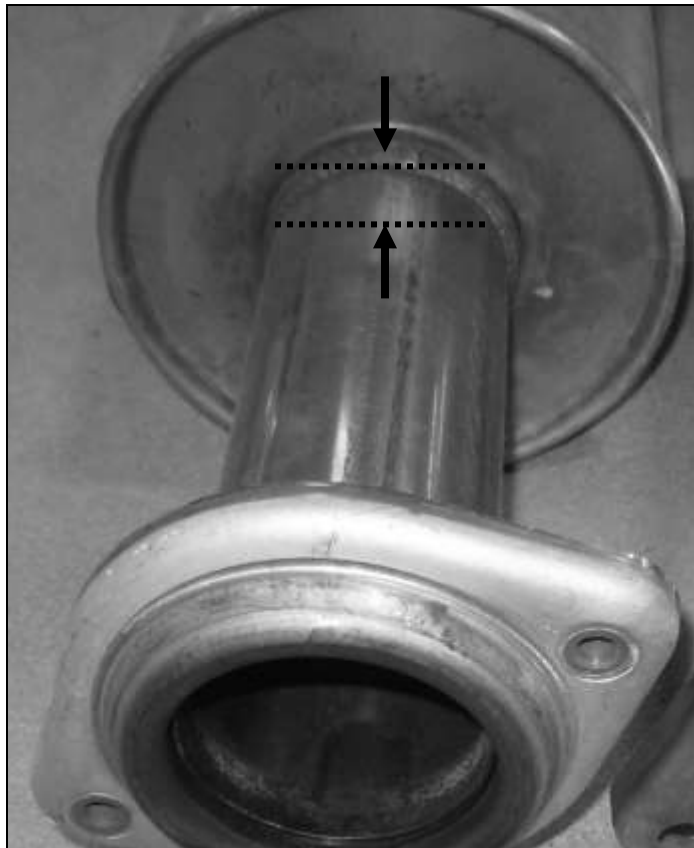

2. Discard the catalyst adapter flange included with your kit (1111-5G267) and replace it with your cut factory 6.2L flange as noted in step #2 of Section B.
3. Repeat the installation in the same sequence as Section B from step 2 onward.