

Rostra External Wiring Harness Repair Kit Installation Instructions

CHRYSLER A604 (41TE)

READ ALL OF THE STEPS BEFORE CUTTING ANY WIRES!

1. Locate and remove the connector of the old harness from the transmission.
2. Installation is easiest and mistakes are avoided when one wire at a time is changed over to the new harness. Although care has been taken to match the repair kit wiring color to the factory wiring color, variations may occur from year to year and model to model. Refer to the diagram below.
3. Cut each wire as far from the original connector as room and the harness allows. Splice using the supplied crimp connectors, staggering the splices approx. 1-1/2" apart. (Splices should not overlap.)
4. Apply heat to the splice insulation to shrink the insulation around the wires.

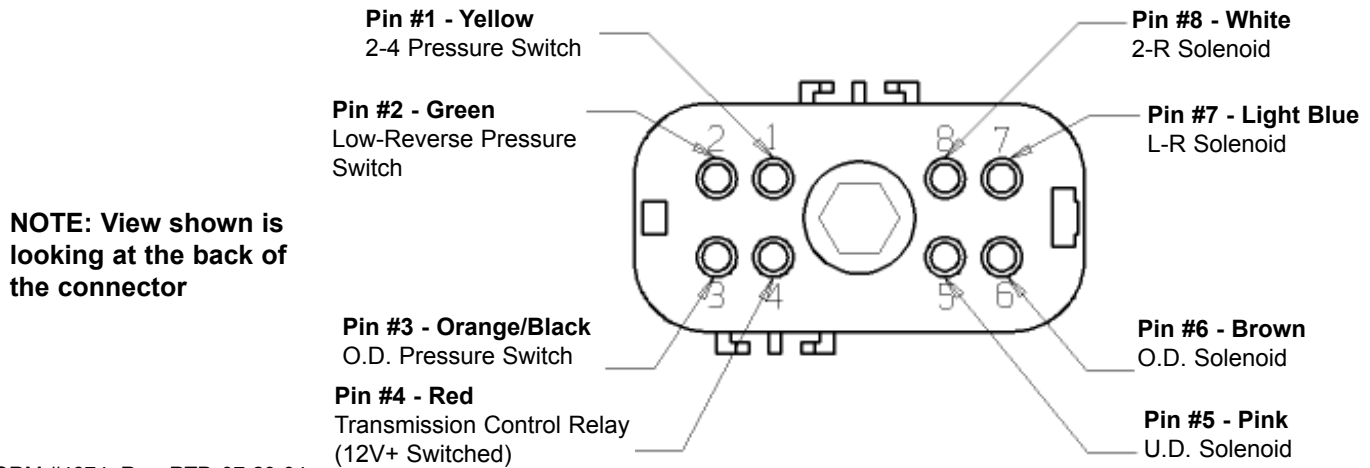

FORM #4874, Rev. RTP, 07-29-04