



**2818 - RANGE ROVER SPORT 2014 - PRESENT**

Installation Instructions



**75 Minutes**

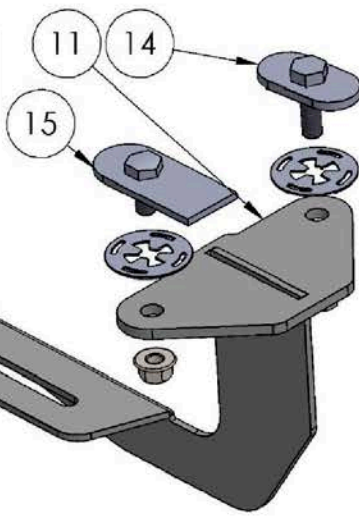

M6 = 8Ft.Lb  
 M8 = 18 Ft.Lb  
 M10 = 35 Ft.Lb

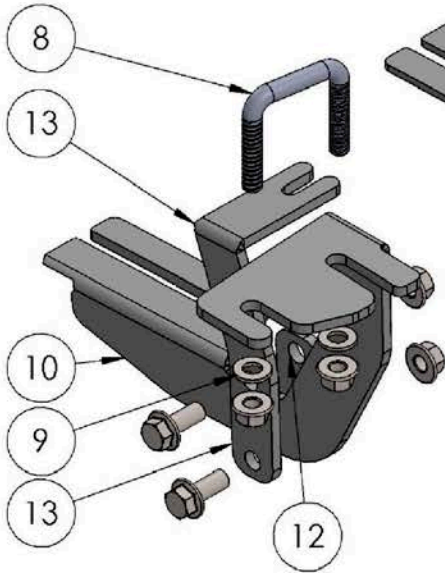

**FRONT**

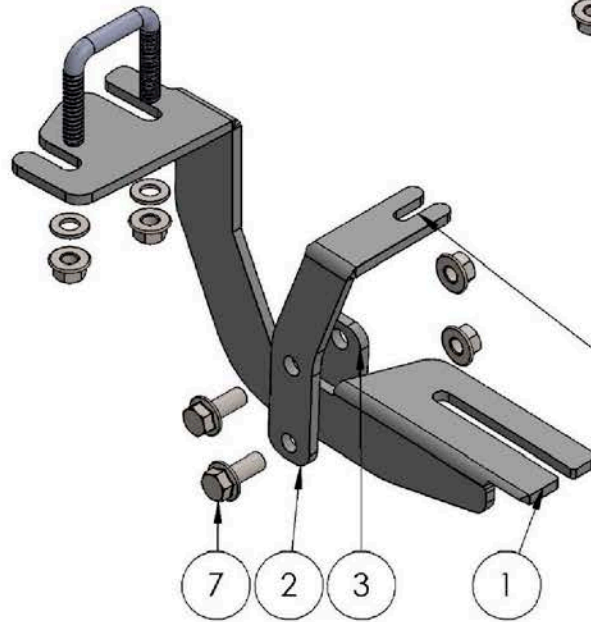

THE BOLT IS ON THE VEHICLES CHASSIS

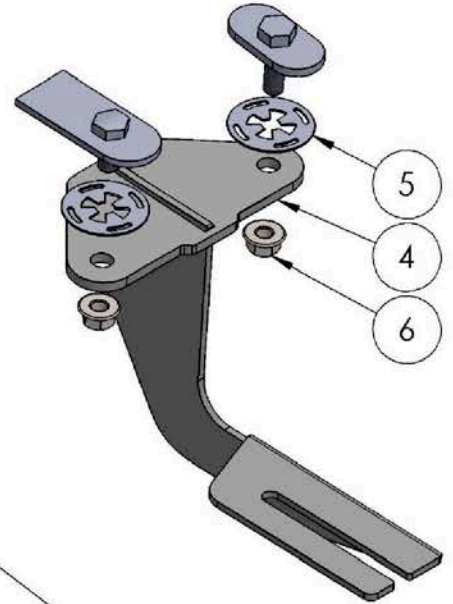

ITEM	PART NUMBER	QTY
1	2818850F0 DRIVER	1
2	2818850F1 DRIVER	1
3	2818850F2 DRIVER	1
4	2818850B0 DRIVER	1
5	HTC 269 - CLIPS (M10)	4
6	DIN 6923 FLANGE NUT - M10	12
7	DIN 6921 FLANGE BOLT - M10 x 25	4
8	HTC 279 - M10 MERKEZ 55	2
9	DIN 125 WASHER - M10	4
10	2818850F0 PASSENGER	1
11	2818850B0 PASSENGER	1
12	2818850F2 PASSENGER	1
13	2818850F1 PASSENGER	1
14	HTC 240 - M10X30 ORTADAN DELIKLİ YAPRAK CIVATA (5X34X60)	2
15	HTC 284 - M1X25 (4X80X35)	2

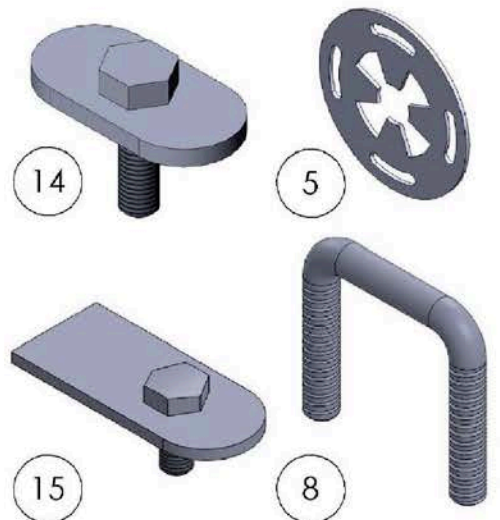



Rear

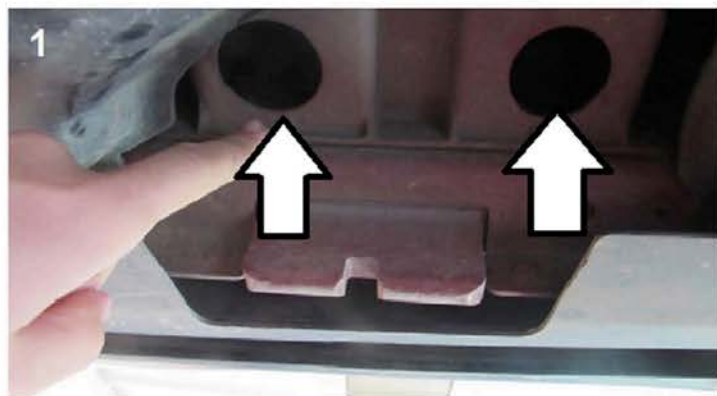

- 1) Locate rear mounting area as shown on image #1
- 2) Install HTC 240 with HTC 269 on the rear most hole as shown on image #2 and #3
- 3) Install HTC 284 with HTC 269 on the forward hole, rear mounting area Image #2 and #3
- 4) Install rear bracket using supplied DIN 6923 Flange Nut 10mm
- 5) Do not tighten anything yet, leave everything hand tight.
- 6) Proceed to front bracket area.

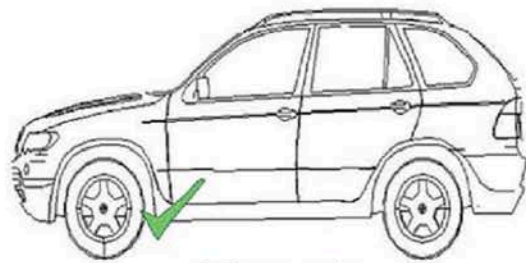

## Front

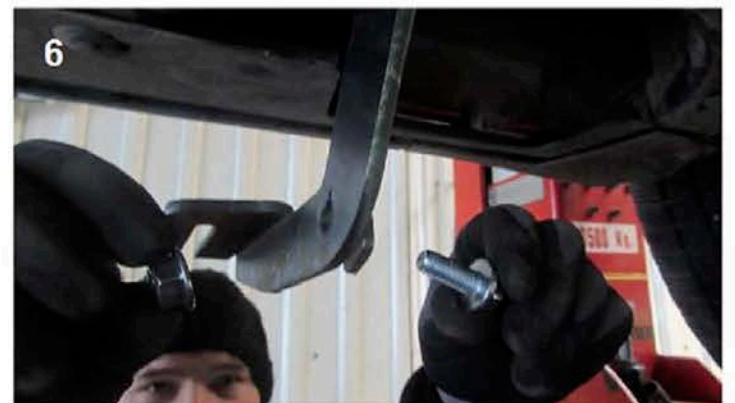
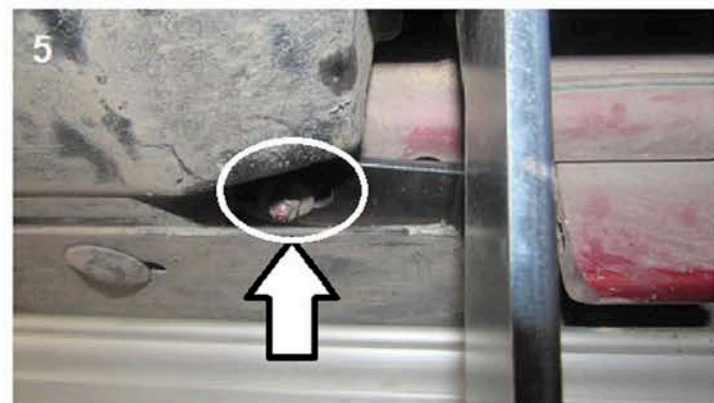
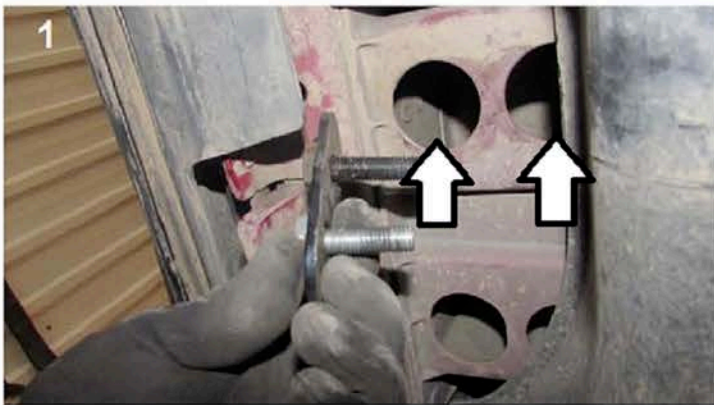

- 1) Locate front mounting area image #1
- 2) Install U bolt HTC 279 with HTC 269 as shown on image #2
- 3) Slide in front mounting bracket as shown on image #3 and attach with DIN 6923 flange nut 10mm. Leave head tight at this point.
- 4) Install extra support as shown on image #4 NOTE the upper portion is attached to a factory mounting point. Loosen nut image #5 and slide extra support do not tighten yet.
- 5) Attach extra support to main front bracket using supplied DIN 6921 and DIN 6923 do not tighten yet. You are now ready to install steps onto brackets.
- 6) Loosen 8mm nuts on steps and slide in place on top of mounting brackets, align and hand tight only.
- 7) Tighten bracket hardware M10 to 35 ft lbs **WARNING** Do not use powertools
- 8) Tighten M8 hardware on bottom of steps to 18 ft lbs. **WARNING** use of powertools may damage the bottom of the steps and will void your warranty.
- 9) Repeat procedure on opposite side.

# 2818 - RANGE ROVER SPORT 2014 - PRESENT

**Note: Use of powertools will damage products and void your warranty**

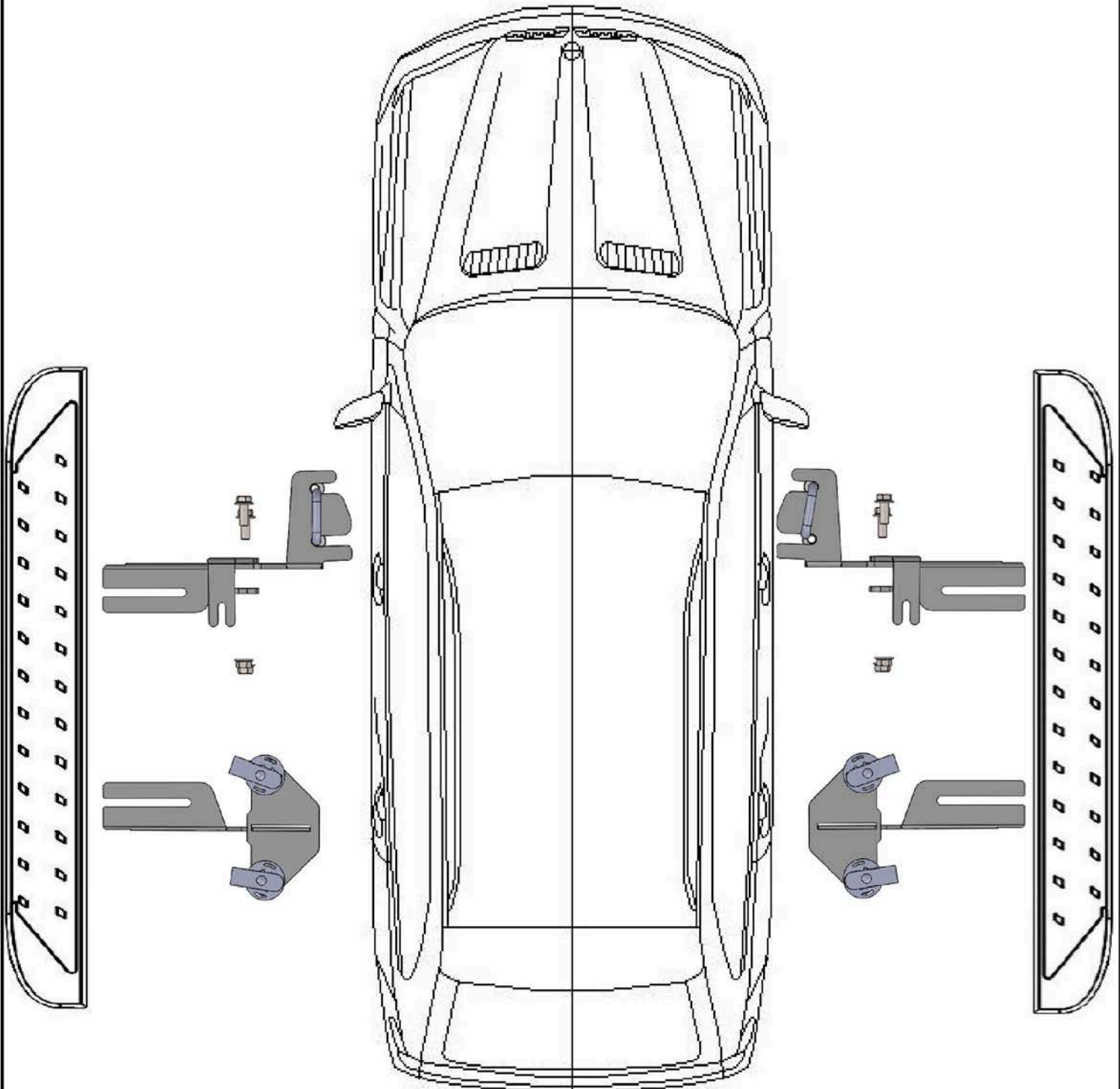

On our website you'll find a wide variety of high-quality Running Boards & Step Bars from Romik.