



JEEP CHEROKEE 2014 - PRESENT

Installation Instructions





90 Minutes

REV 3

850-AB-NS

NOTE: Before starting this installation make sure all the hardware is included and this part number matches your vehicle.
NOT : Montaj işlemine başlamadan önce eksik parça olup olmadığını ve ürün kodunun aracınızın kodu ile uyumlu olup olmadığını kontrol ediniz.

JEEP CHEROKEE 2014 - PRESENT

4		DIN 6921;M10x25
6		DIN 6923;M10
2		DIN 6923;M8

4		DIN 125;M10
2		HTC269 M10

2		HTC 230 M10x30
4		DIN 933 M6x30
4		DIN 934 M6
8		DIN 125 M6

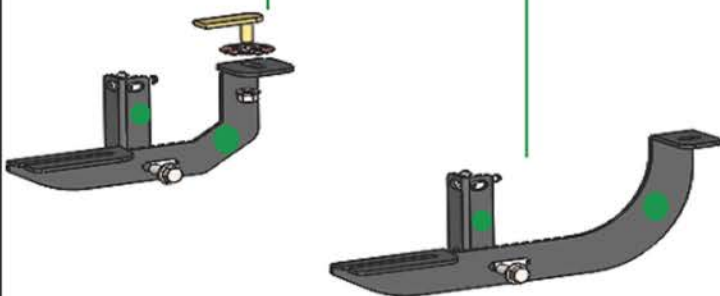
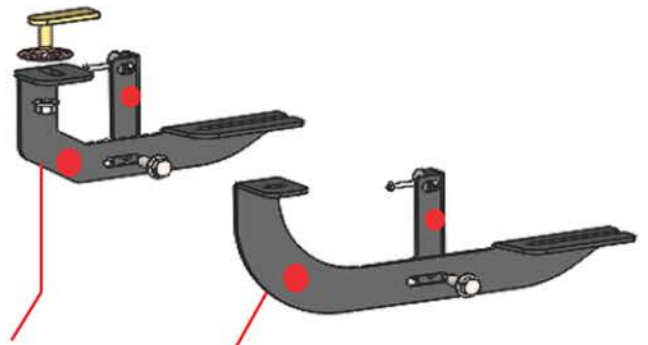

M6 = 8 Ft.Lb
M8 = 18 Ft.Lb
M10 = 35 ft.Lb

ATTENTION: DRILLING REQUIRED

ATTENTION PLEASE! : DO NOT TIGHTEN ALL OF THE SCREWS UNTIL ALL OF THE PARTS ARE INSTALLED.

Keep your accesories clean. To prevent corrsion and to maintain your high quality finish, wax or polish regularly with quality stainless polish. Use a non abrasive type automotive wax. Any use of abrasive soaps, polishes or waxes can be detrimental to the finish.

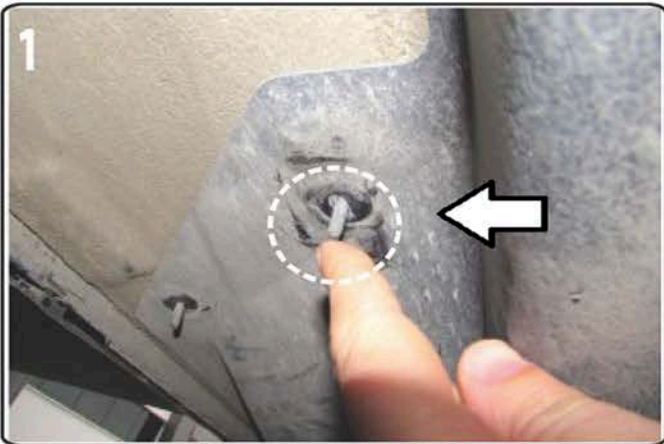

1) Locate front bracket mounting point, if equipped remove factory nut

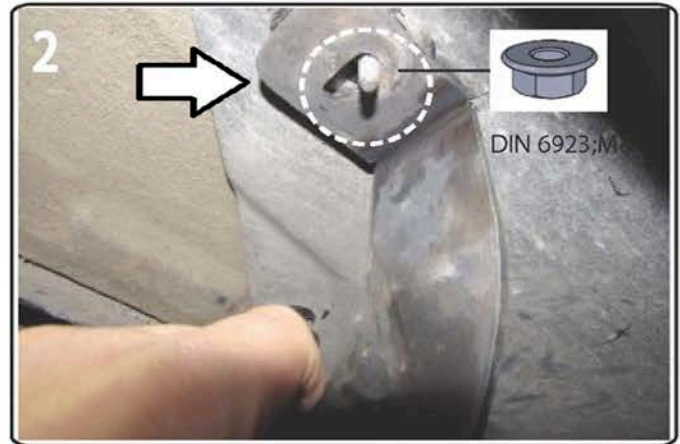

2) Install front mounting bracket using supplied DIN 6923 nut do not tighten

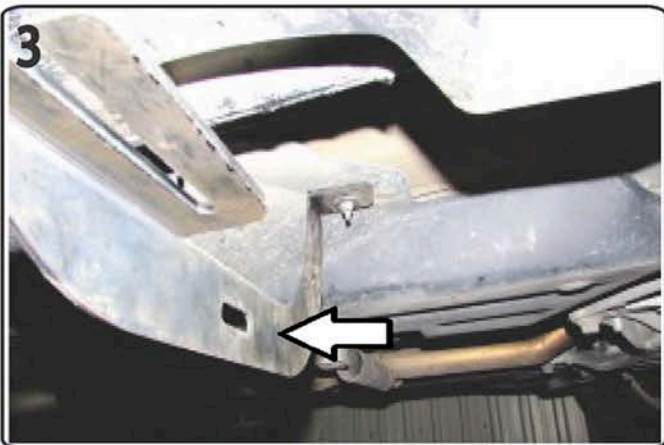

3) Attach extra support to main bracket using supplied M8 hardware

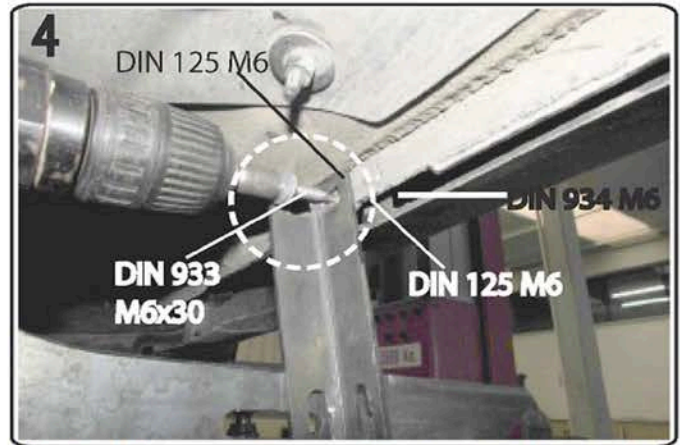

4) Proceed to stage extra support bracket and mark spot for drilling hole
Drill a pilot hole with a 13/64 drill bit, finish hole with 5/16 drill bit



5) Install hardware on upper extra support mounting point do not tighten, you are now ready for the rear bracket.

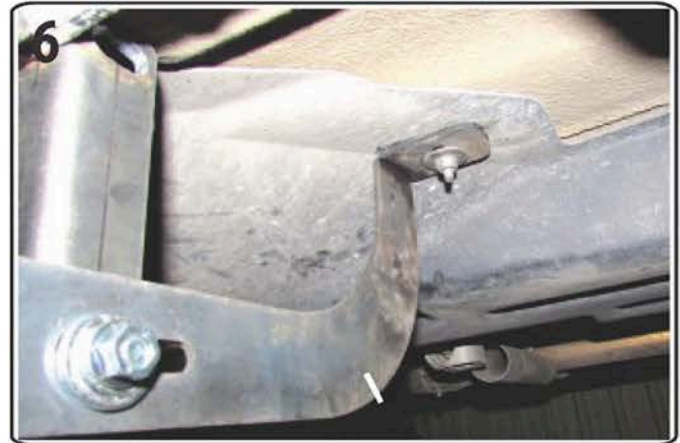

HINT: In order to get the hardware in place it is advised to pull back on the cladding and place a "Paint stir stick" or similar so you can safely drill the pinch weld. Once you drill the hole insert the bolt going from the outside towards the inside so the head of the bolt is hidden by the factory cladding. Another option is to remove the cladding but this adds 30 minutes per side to the installation.

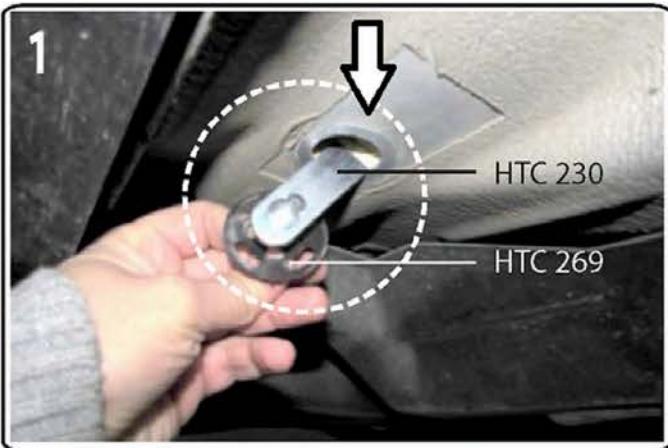

1) Locate rear bracket mounting point insert HTC 230 with HTC 269



2) Attach rear mounting bracket as shown above

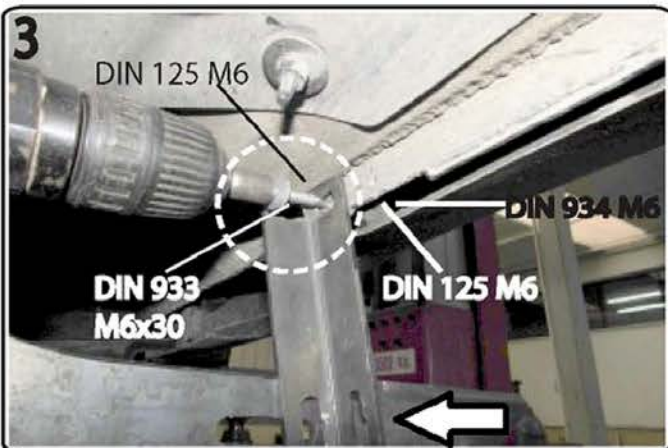

3) Attach extra support as shown and drill pinch weld to 5/16 hole



4) Attach extra support bracket with supplied hardware M6



5) Loosen M8 hardware on back of steps
 6) Attach steps to brackets hand tight only
 7) Proceed to tighten brackets M6 to 8 ft lbs M8 to 18 ft lbs and M10 to 35 ft lbs
 8) Proceed to tighten setps hardware M8 to 18 ft lbs



9) Repeat procedure on opposite side

WARNING: Use of powertools will void the warranty

JEEP CHEROKEE 2014 - PRESENT

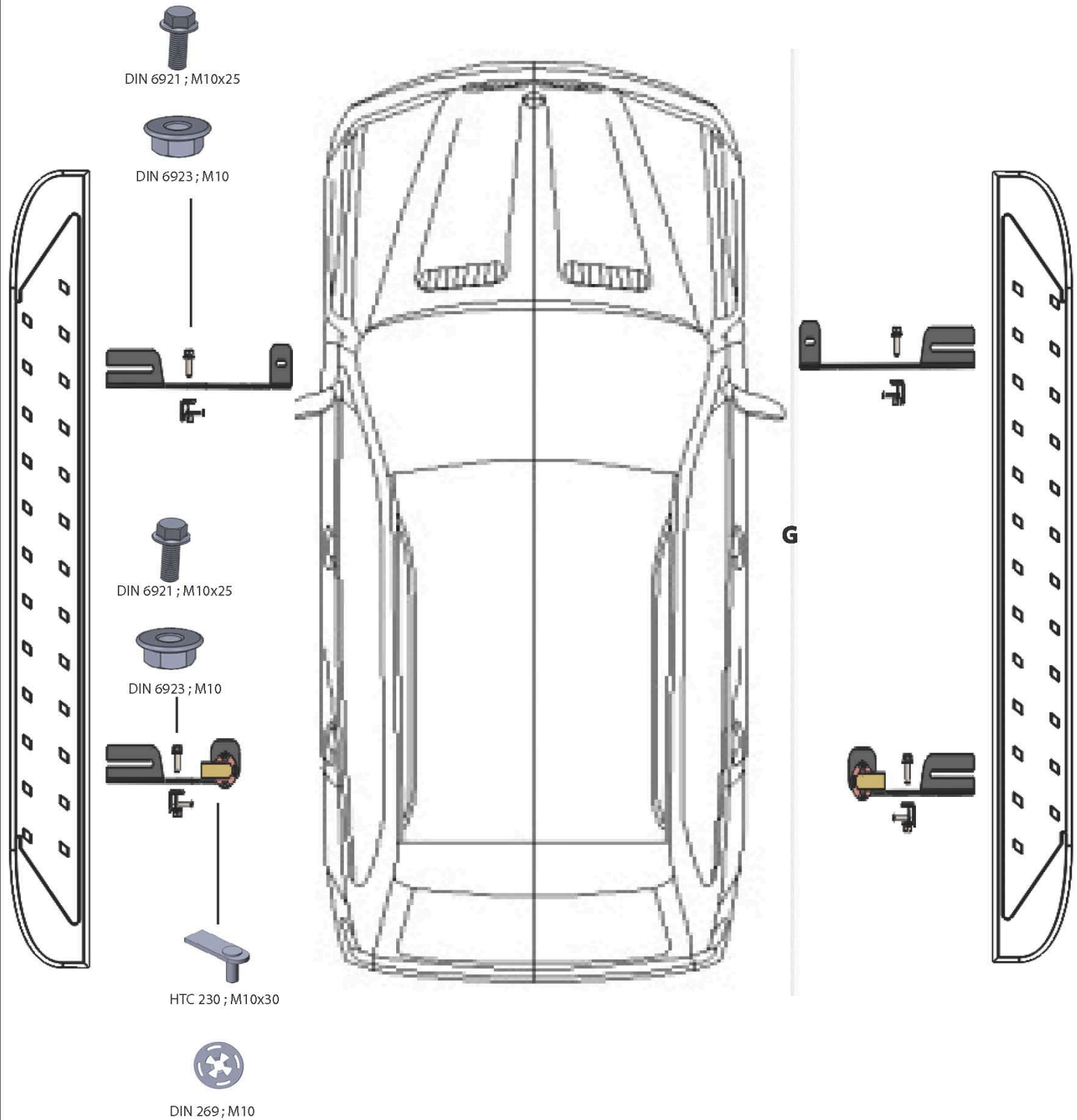

On our website you'll find a wide variety of high-quality Running Boards & Step Bars from Romik.