

ROMIK

3931 – TOYOTA HIGHLANDER 2014 - PRESENT

Installation Instructions



90 Minutes

NOTE: This installation requires removing and trimming the plastic panels under the vehicle. Before starting this installation makes sure that all hardware matches these instructions.

M6 = 8Ft.Lb
M8 = 18 Ft.Lb
M10 = 35 Ft.Lb

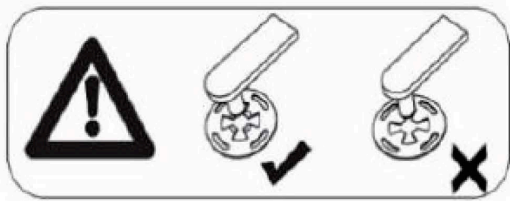
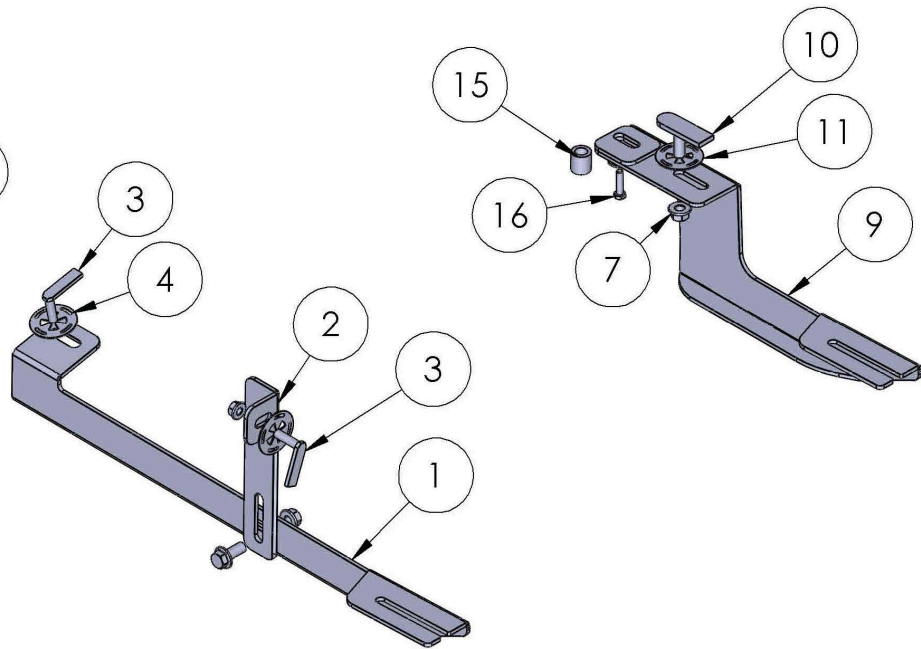
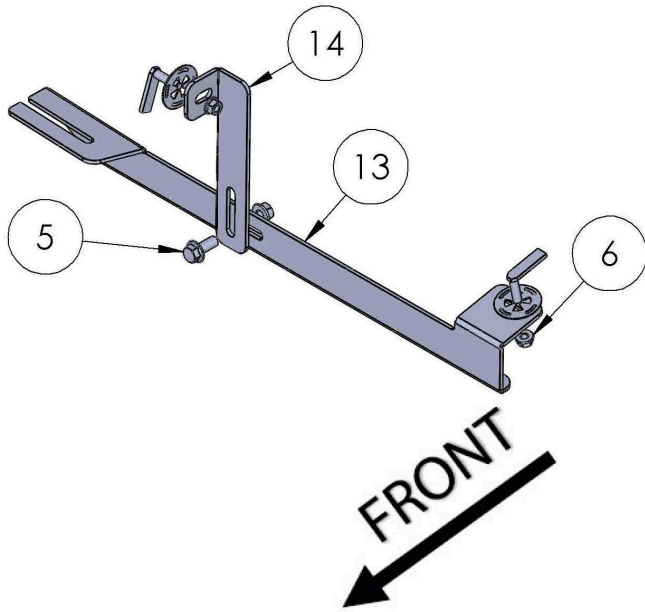
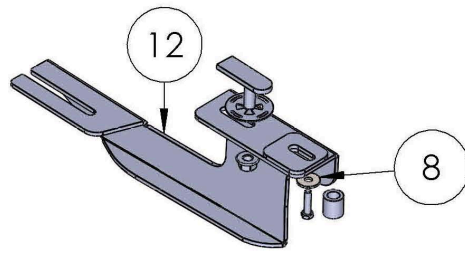
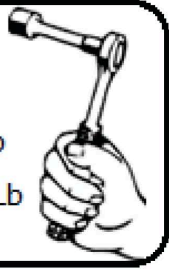

ITEM	PART NAME	QTY
1	3931850F0 DRIVER	1
2	3931850F1 DRIVER	1
3	HTC 226 - M8X30 TIRNAK CİVATA (4X10X37)	4
4	HTC 271 CLIPS M8	4
5	DIN 6921 FLANGE BOLT - M10 x 25	2
6	DIN 6923 FLANGE NUT - M8	4
7	DIN 6923 FLANGE NUT - M10	4
8	DIN 125 WASHER - M6	2
9	3931850B0 DRIVER	1
10	HTC 238 - M10x30(5x20x60)	2
11	HTC 269 - CLIPS (M10)	2
12	3931850B0 PASSENGER	1
13	3931850F0 PASSENGER	1
14	3931850F1 PASSENGER	1
15	SPECIAL PIPE Ø12 x Ø19 x 20	2
16	DIN 933 BOLT M6x30	2

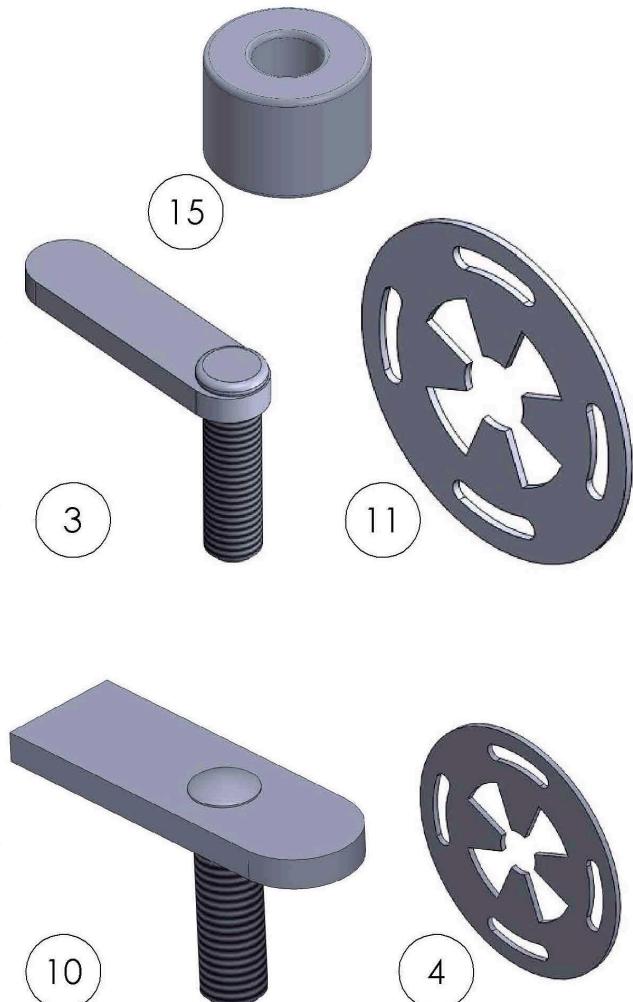

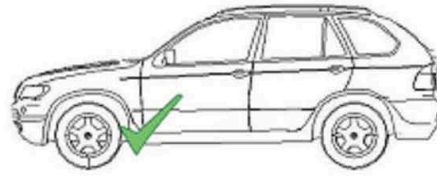

M6 = 8 Ft.Lb

M8 = 18 Ft.Lb

M10 = 35 ft.Lb

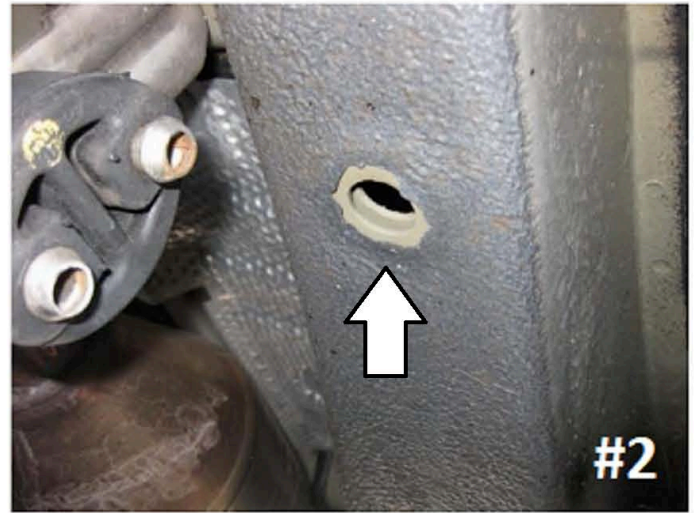

- 1) After removing the plastic panels locate rubber plug image 1 and remove.
- 2) Insert HTC 226 and install front bracket, Hand tight only.
- 3) Locate and remove rubber plug on rocker panel as shown on image 4
- 4) Install HTC 226 on rocker panel hole.
- 5) Install extra support bracket and attach to main bracket with DIN 6923 M10 bolt and nut
- 6) Hand tight everything and move to rear bracket area.

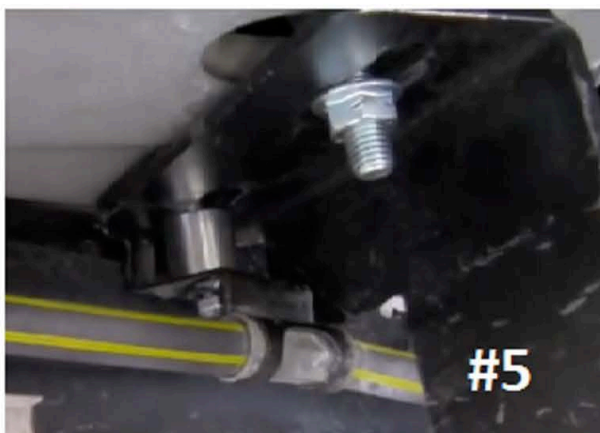
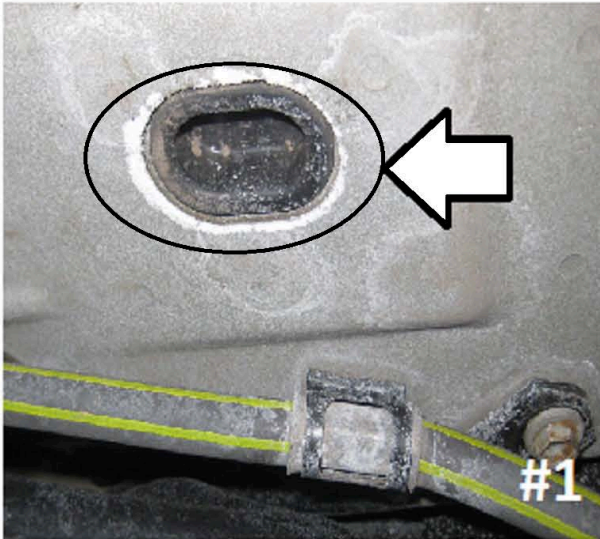
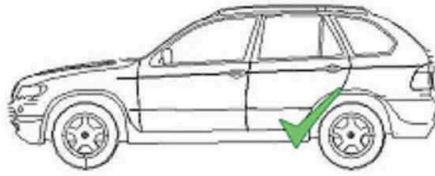

- 1) Locate rear mounting area image 1 and remove rubber plug.
- 2) Remove brake line holder bolt image 2
- 3) Insert HTC 238 and proceed to install bracket hand tight only
- 4) Attach brake line with supplied spacer and M6x30 bolt hand tight only
- 5) proceed to install running boards, align hand tight only
- 6) Proceed to tighten hardware on brackets M6 to 8 ft lb, M8 to 18 ft lb and M10 to 35 ft lb
- 7) Once brackets are installed and tight proceed to tighten running board to 18 ft lb

Plastic Panel modifications

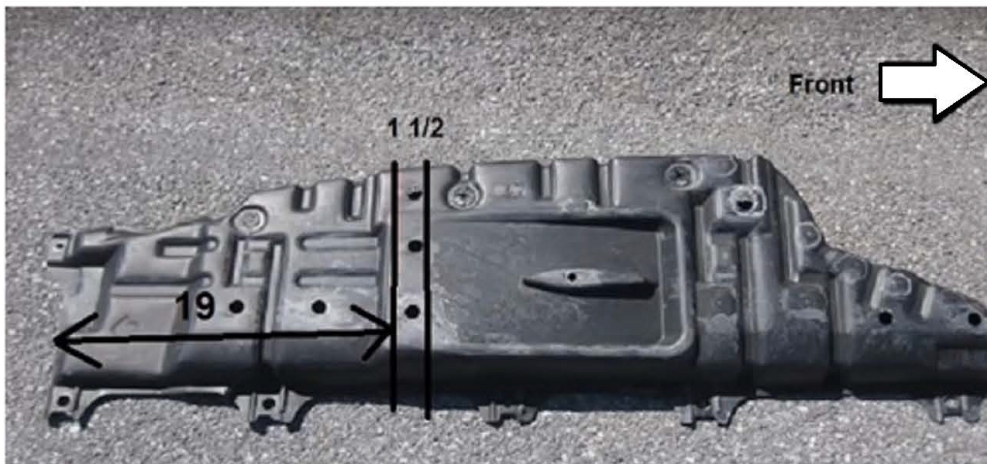
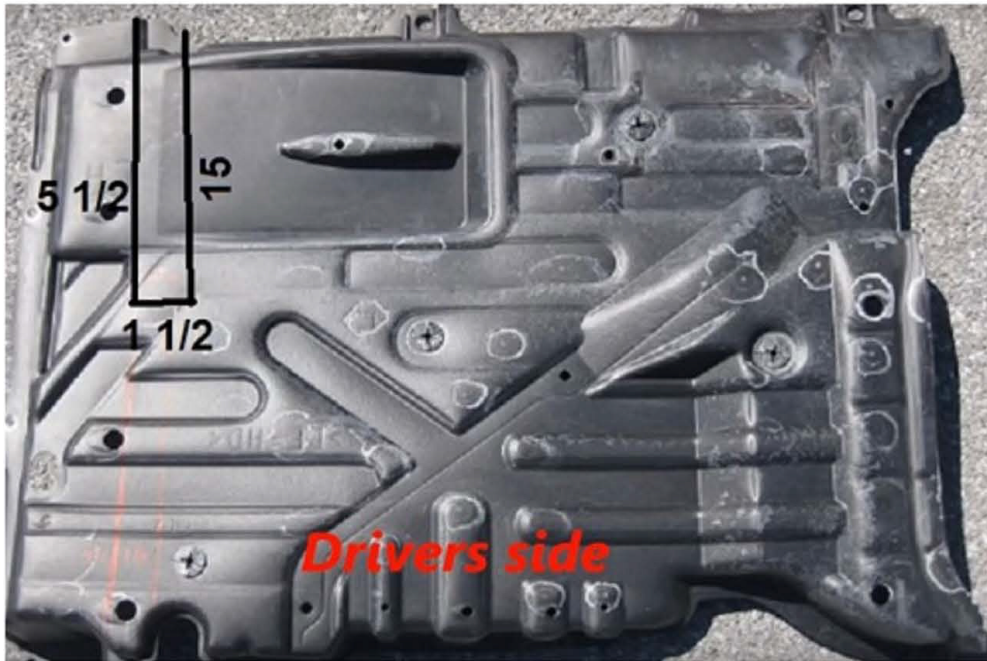

After cutting the panels proceed to install.

Note: Use of power tools will void warranty.

ATTENTION PLEASE! : DO NOT TIGHTEN ALL OF THE SCREWS UNTIL ALL OF THE PARTS ARE INSTALLED.

Keep your Romik accesories clean. To prevent corrsion and to maintain your high quality finish, wax or polish regulary with quality stainless polish. Use a non abrasive type automotive wax. Any use of abrasive soaps, polishes or waxes can be detrimental to the finish.

3931 – TOYOTA HIGHLANDER 2014 - PRESENT

Warning: Use of power tools will void the warranty

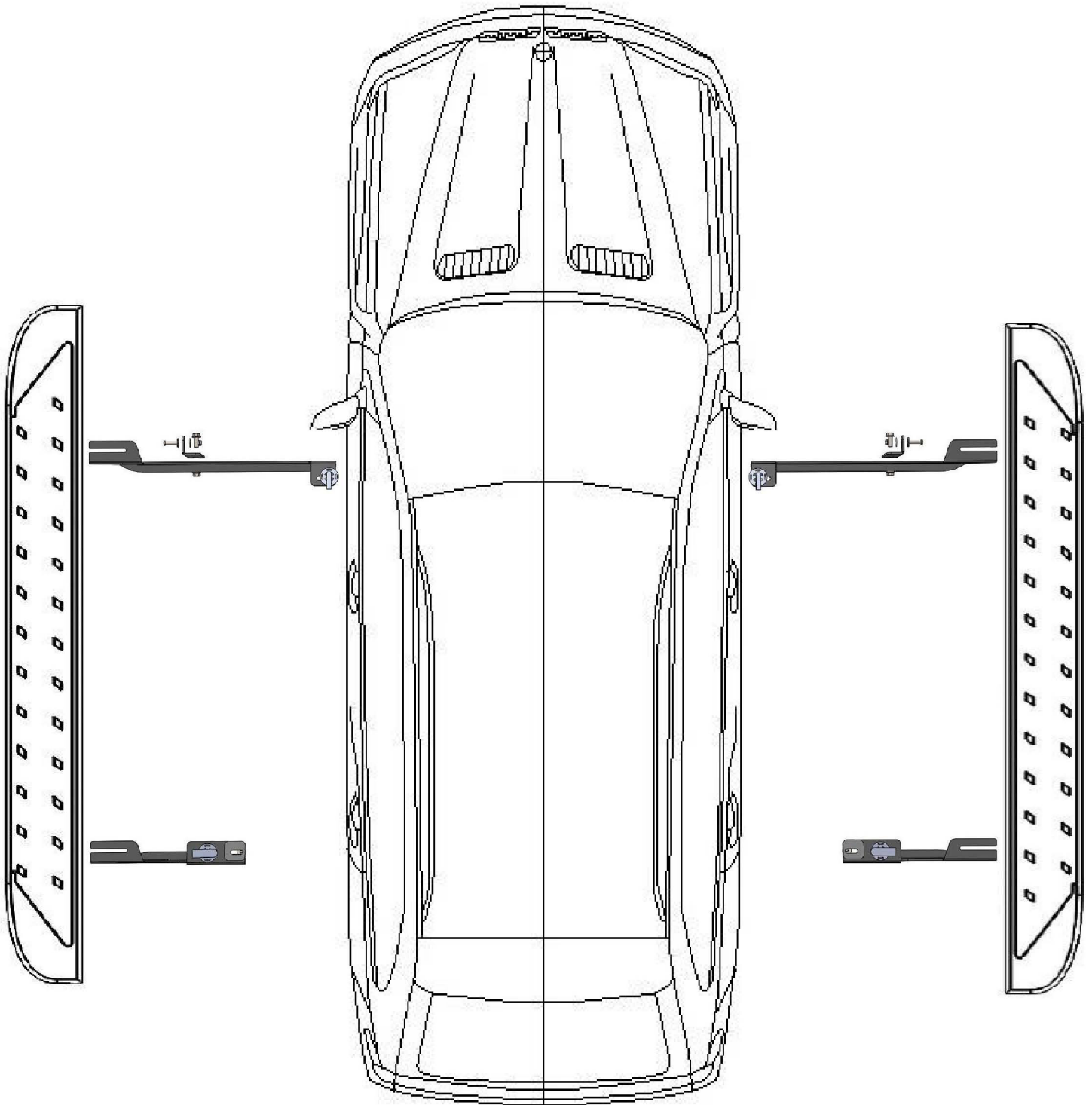

ATTENTION PLEASE! : DO NOT TIGHTEN ALL OF THE SCREWS UNTIL ALL OF THE PARTS ARE INSTALLED.

Keep your Romik accessories clean. To prevent corrosion and to maintain your high quality finish, wax or polish regularly with quality stainless polish. Use a non abrasive type automotive wax. Any use of abrasive soaps, polishes or waxes can be detrimental to the finish.