



INSTALLATION GUIDE
2009-CURRENT
DODGE RAM



PRODUCT CODE:
448 & 449



TOOLS NEEDED

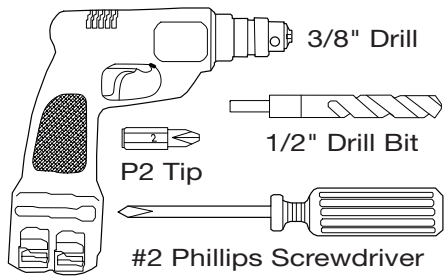

COMPONENTS INCLUDED

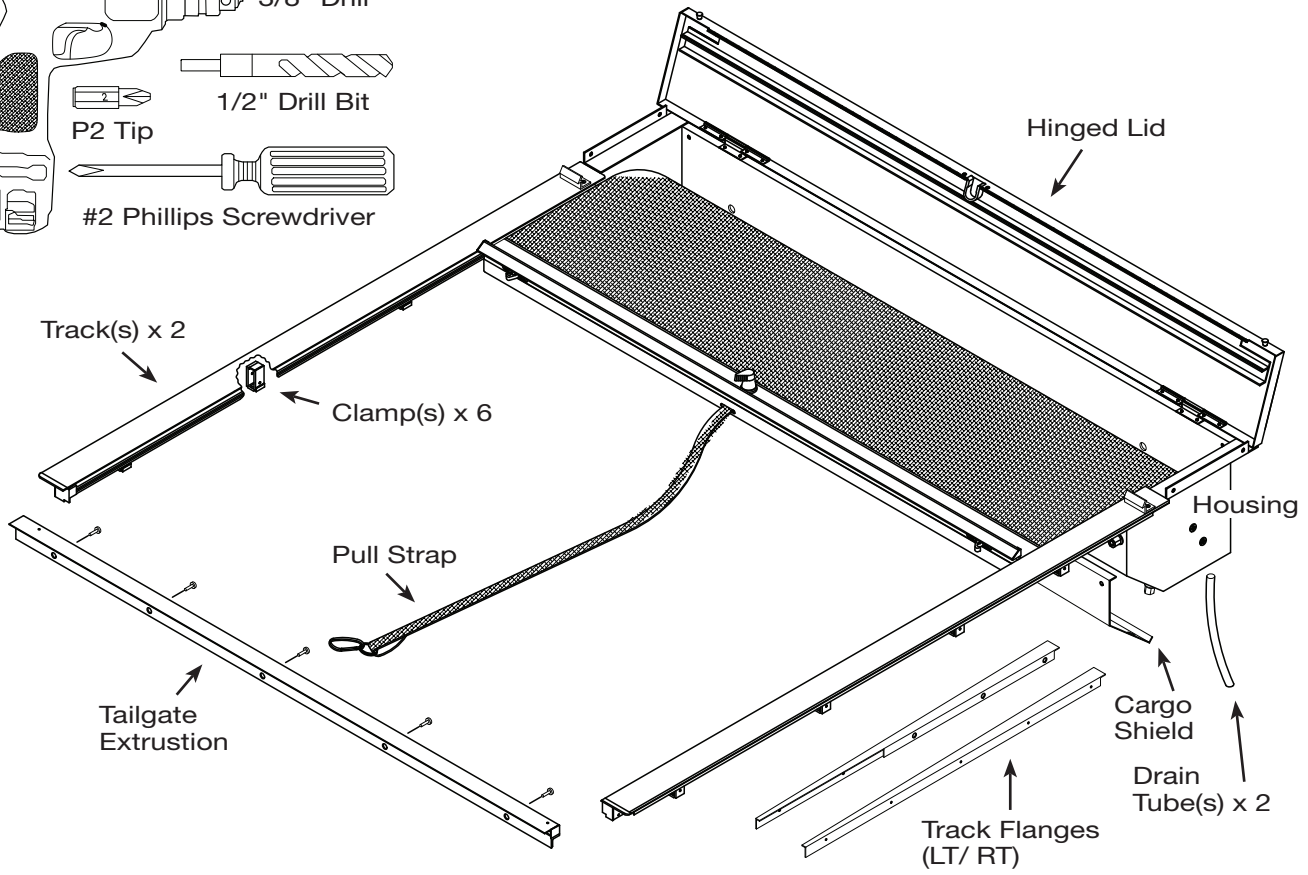

STOP!

IF YOU HAVE A PLASTIC DROP-IN BEDLINER, BE SURE TO FOLLOW STEP 1 ON THE NEXT PAGE.



IF NO BEDLINER IS PRESENT, PROCEED TO STEP 2.

STEP 1: BEDLINER MODIFICATION

Note: If the truck is equipped with a plastic drop-in bedliner, some alteration will be necessary. **If no bedliner is present, proceed to Step 2.**

The dotted lines in (**Diagram 1**) depict the more common **under-the-rail** liner modifications.

- A.** Remove the bedliner from the truck and using a jig saw with a medium tooth blade, remove the bulkhead portion of the liner as indicated. Replace the bedliner in the truck.

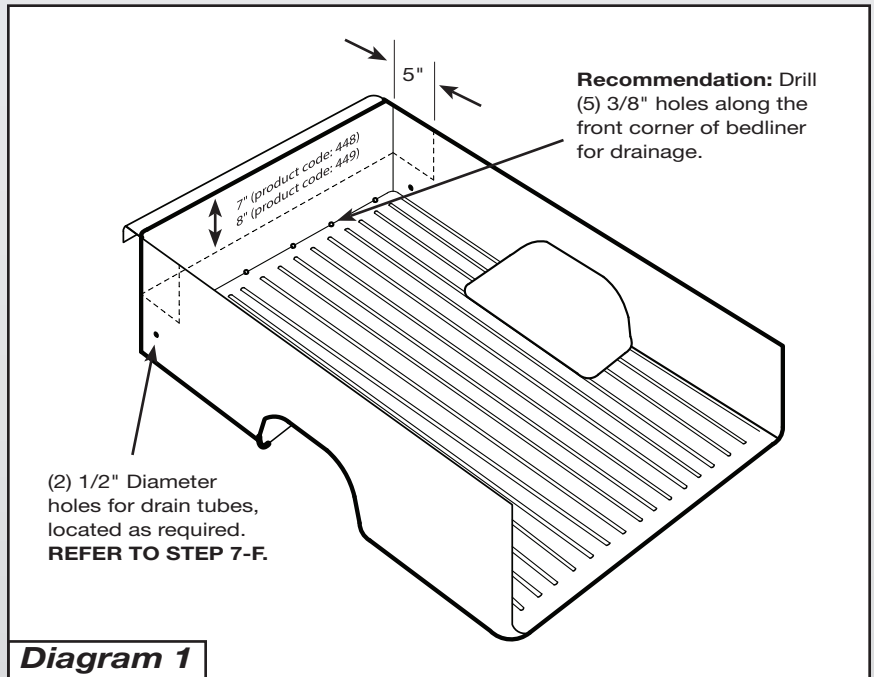

- B.** The top of the tailgate protector panel needs to be 1 3/4" from the top of the tailgate. With the panel still in place measure down from the top of the tailgate 1 3/4" and mark a straight cut line across the top of the panel (**Diagram 2**). If the existing panel is below the 1 3/4" line, proceed to **Step 2**. If the plastic protector panel is above the line, remove the panel and carefully make a straight cut to remove that portion of the panel (**Diagram 3**). Replace the plastic protector panel.

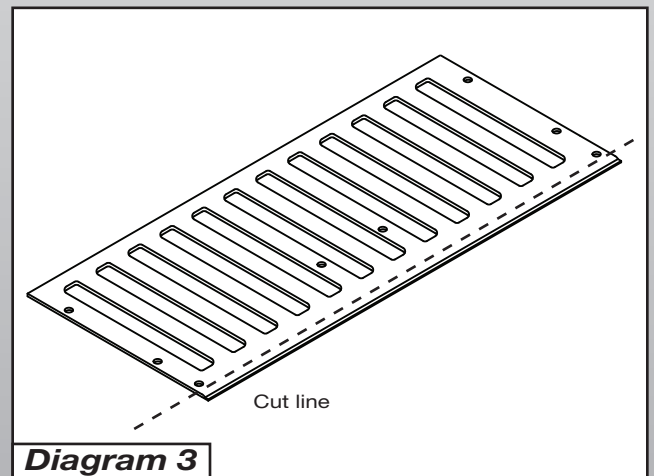
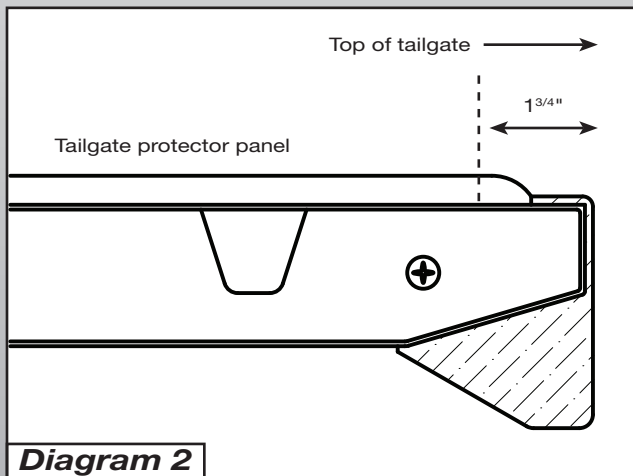

STEP 2: INSTALL THE MOUNTING FLANGES

- A.** Place the Mounting Flange onto the down flange of the bedrail, keeping the forward notches seated against the bulkhead and being sure that the top of the flange is exactly flush with the top of the bedrail (*Diagram 4*).

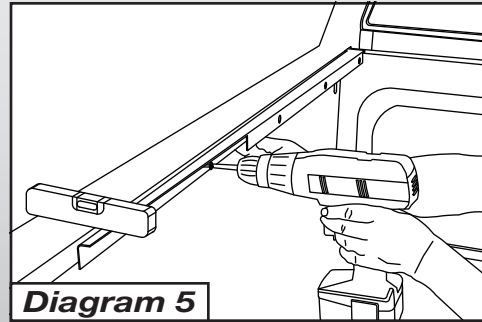
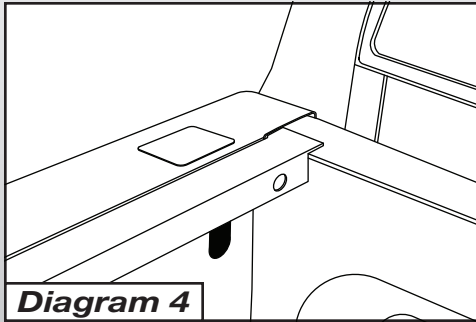

- B.** With the Mounting Flange flush with the bedrail use #8 x 3/4" self tapping screws to secure the Mounting Flanges to the bedrails (*Diagram 5*).

STEP 3: INSTALL THE HOUSING

- A.** If desired, install the Stake-Pocket Hole Covers where necessary (*Diagram 6*).
- B.** Place the Housing Assembly onto the Mounting Flanges (*Diagram 7*). This best accomplished with two people. Center the Housing between the bedrails with the back of the Housing up against the bulkhead. **Do not fasten the Housing in place at this time.**

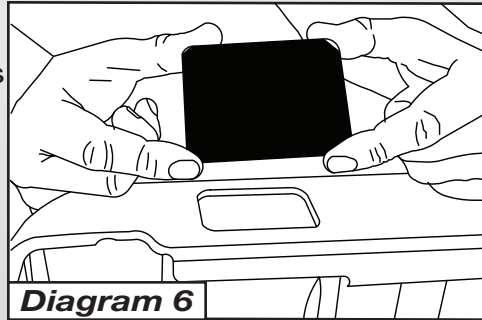

- C.** Lift the Lid on the Housing and lean it against the cab (*Diagram 8*). Place a rag between the Lid and cab to prevent scratches.

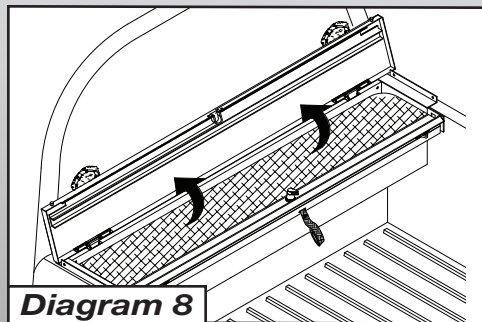
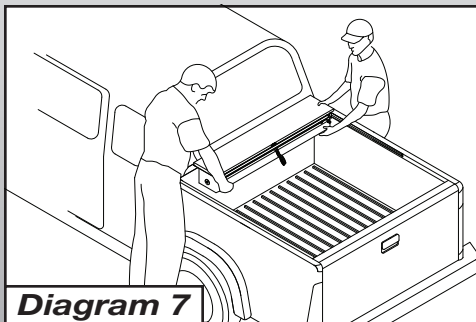

STEP 4: INSTALL THE TRACKS

- A.** Making sure to leave the Pull Strap connected to the threaded shipping stud, rotate the Lock Lever to the 10 o'clock position (*Diagram 9*).

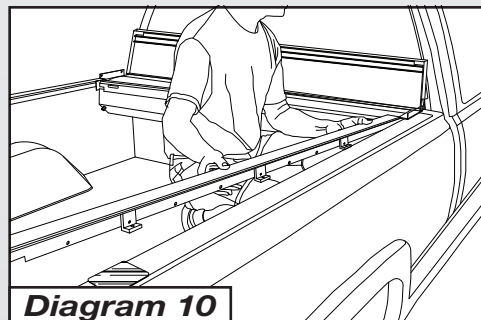
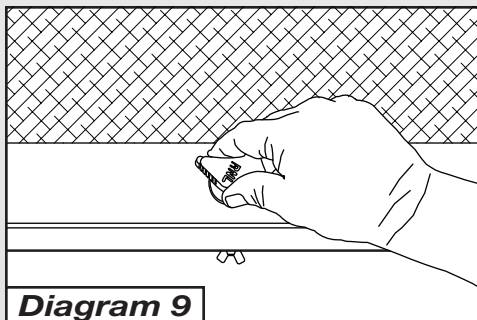

- B.** Unwrap the Tracks and locate the supplied Bed Clamps that are taped together, along with the bolts and washers. Unwrap the Clamps and set them in the bed of the truck. Carefully place the Tracks on the bedrails (*Diagram 10*) and key them onto the Housing Stems (*Diagram 11*), being sure that the Handle is properly engaged into the Tracks.

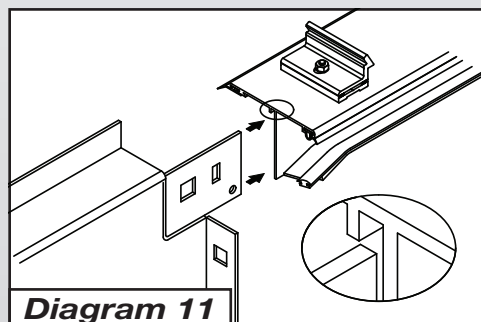

- C.** Attach the back Clamps very loosely to the Tracks to be sure that the Tracks do not fall off of the bed rail while proceeding (*Diagram 12*).

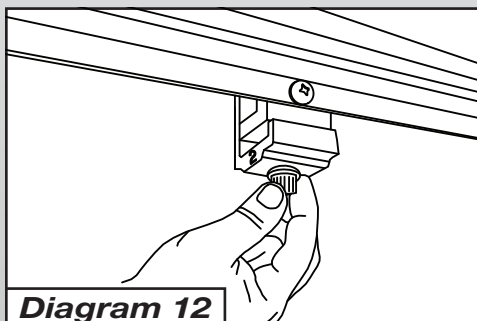

Note: The Clamps are different and are marked to note the difference. The Clamps marked "2" are used at the front and back locations, the Clamp marked with an "X" is used at the center location (*Diagram 13*).

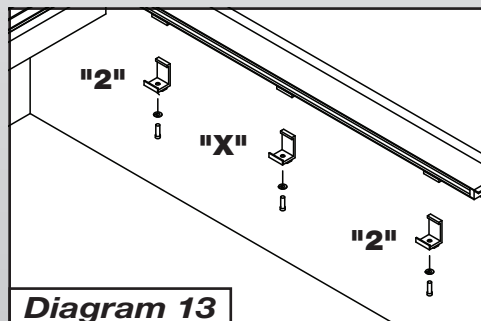

- D.** Use the #10-24 x 1/2" truss head screws and Cargo Nuts supplied to secure the Tracks to the Housing Stems (*Diagram 14*). Tighten these connections securely.

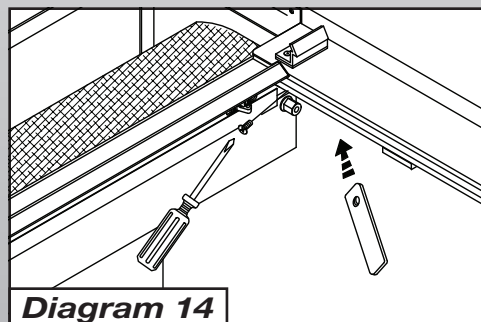

- E.** Attach the remaining Clamps very loosely. **Do not tighten yet.**

STEP 5: INSTALL THE TAILGATE EXTRUSION

- A.** Lower the tailgate. Using a tape measure, locate and mark the center of the tailgate (*Diagram 15*).
- B.** While holding the Tailgate Extrusion square and centered on the tailgate, use the self-taping screws provided and a power screw gun to secure the Tailgate Extrusion to the tailgate.
- C.** With the Tailgate Extrusion secured, carefully close the tailgate, being cautious not to strike the ends of the Tracks.

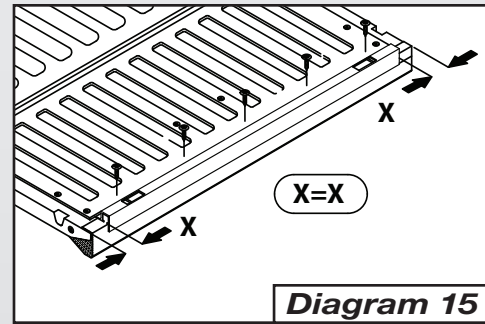

Diagram 15

STEP 6: ORIENTING THE TRACKS TO THE TAILGATE

- A.** Move to the front of the bed, lift up slightly on the Housing and shift each side back toward the tailgate (*Diagram 16*) so that the Track End Caps contact the inside surface of the tailgate. Make sure the Track End Cap Metal Blocks contact the Tailgate Extrusion End Caps (*Diagram 17*). **Note that if the Tracks are not positioned as shown, the Latch Mechanism will not function correctly.**

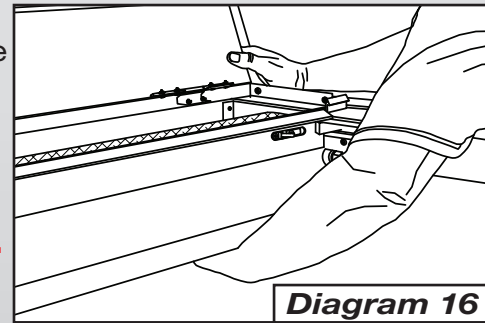

Diagram 16

- B.** With the Tracks in the correct position, you may now tighten the Clamps in the order shown (*Diagram 18*), taking care to make sure the Tracks remain level. **Do not use a power or pneumatic screw gun. Over tightening Track Clamps can cause an indentation in the bedrails.**

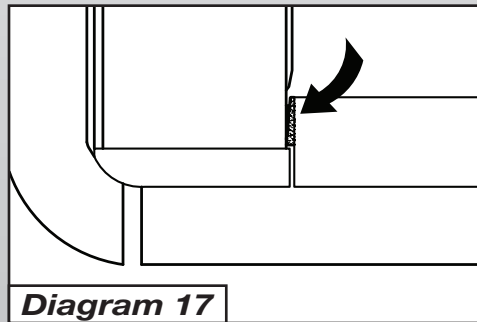

Diagram 17

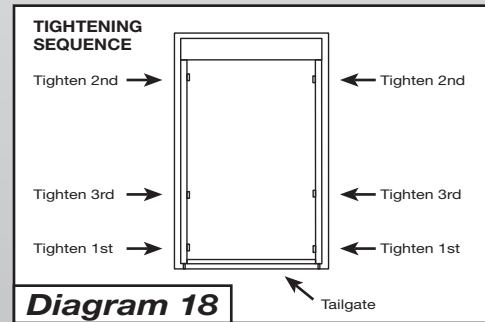

Diagram 18

- C.** If the Track pitches upward, loosen the Clamp, rotate the Track level and install the optional Angularity Adjustment Screw as shown (*Diagram 19*). Tighten the screw until it biases against the bedrail down-flange as shown.

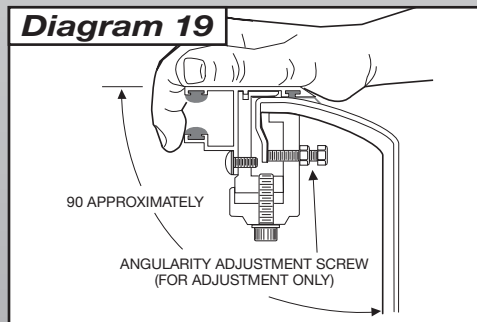

Diagram 19

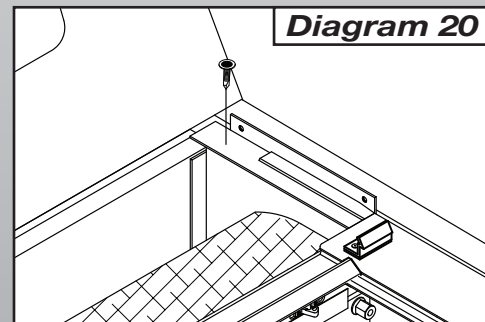
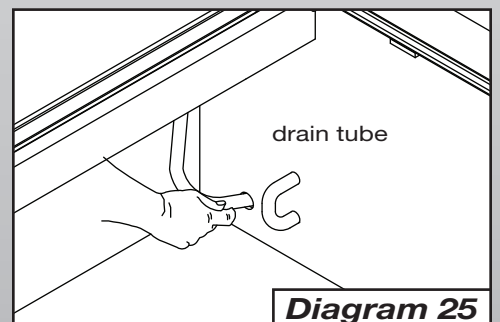
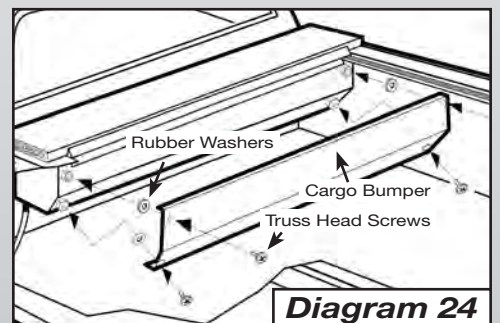
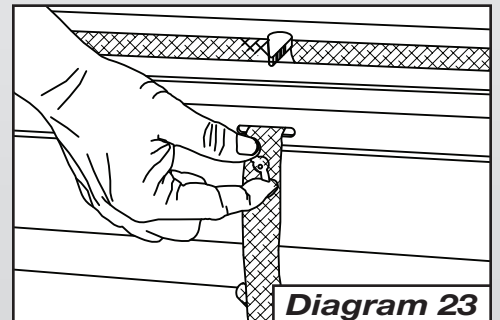
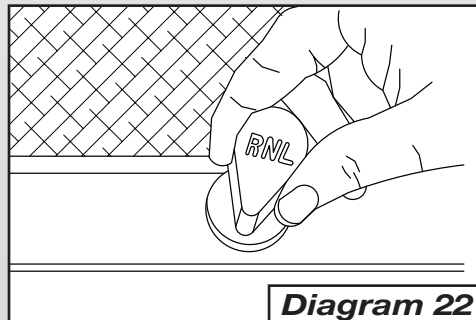
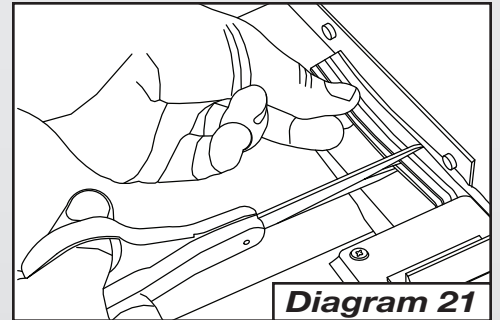

Diagram 20

- D.** Using a #8 x 3/4" self-taping screw and a power screw gun, secure the Housing to the Track Flange (*Diagram 20*). Repeat for the other side.

STEP 7: INSTALL CARGO SHIELD & DRAIN TUBES

- A.** Trim the track gasket 1" from the end of the Track (*Diagram 21*).
- B.** Rotate the Lock to the 7 o'clock (closed) position (*Diagram 22*) then remove the plastic wing nut and detach the Pull Strap from the threaded Stud (*Diagram 23*). Pull the Cover closed and latch it to the tailgate. **Note: Do not allow the Cover to retract while the Housing Lid is open.**
- C.** Before lowering the Housing Lid, turn the Lid Pin Knobs 1/4 turn clockwise, which will cause the pins to pop in if they are not already. Lower the Housing Lid, being sure that the Lid Pins snap into the receptors located on the Tracks.
- D.** To open the Cover, pull back slightly on the Handle to relieve spring tension from the Latch Mechanisms and turn the Lock Lever clockwise to the 10 o'clock (unlatched) position. While holding the pull strap, allow the Cover to retract back into the housing with just enough force to reset the Lock Lever.
- E.** Use the 14-20 x 1/2" truss head screws and rubber washers supplied, to secure the Cargo Shield (*Diagram 24*). **Note: The rubber washers go on the inside of the Cargo Shield.**
- F.** Attach one end of the Drain Tube to the Drain Fitting on the bottom of the Housing, insert the other end of the Tube through the existing hole, on the side of the truck next to the tie down hook (*Diagram 25*), Repeat for the other side. If a bed liner is present, a 1/2" hole may need to be drilled through the bed liner to access the existing hole in the truck.
- G.** **Always make sure the Pull-Strap is securely clipped to a fixed point in the bed.**



STEP 8: TEST UNIT OPERATIONS

In Step 6 the Cover was opened (retracted). This should have caused the Lock Lever to enter the Lock Pocket and rotate the 7 o'clock (latched) position.

A. To close the Cover, pull the Pull-Strap hand-over hand, allowing the excess to fall into the bed until you can reach the Handle. Place your hands evenly spread on the Handle and pull the Handle until it contacts the Tailgate Extrusion. As the Handle contacts the Tailgate Extrusion the spring loaded Latches (which were energized when the Cover was retracted) will automatically trip, simultaneously latching the Cover to the tailgate and side Tracks.

B. To open the Cover, pull back slightly on the Handle to relieve spring tension from the Latch Mechanisms and turn the Lock Lever clockwise to the 10 o'clock position. The cover should retract on its own with only a slight push to set it into motion. When the Cover is retracting it is best to hold the Pull-Strap and allow it to slip through your fingers as the Cover travels. Applying pressure to the Pull-Strap as it slips through your fingers will act as a braking action, preventing the Handle from slamming into the Lid at high speed. The cover must retract with only enough force to rotate and reset the Lock Lever and Latching Mechanism.

STEP 9: OPENING AND CLOSING / ADJUSTMENT THE HINGED LID

To Open:

A. Grasp the Latch Pin Knobs, pull out and turn knobs 90° to hold Pin in the unlock position. Grasp the Lid and lift. Rest the Lid against the back of the cab to hold open for service or cleaning (*Diagram 26*).

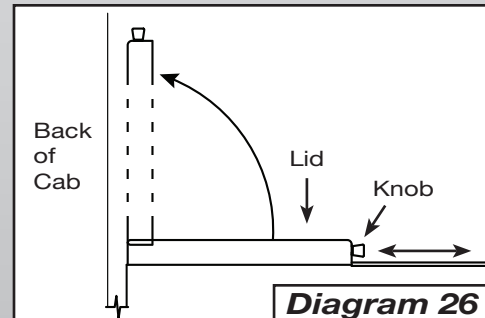

To Close:

A. Lower the Lid and return the Latch Pins to locked position by turning the knobs 1/4 turn.

If Lid is loose:

A. Raise Lid and loosen the nylock nut on each Lid Latch Bracket, move the top half of the bracket one notch toward the tailgate. Tighten both nuts and close lid (*Diagram 27*).

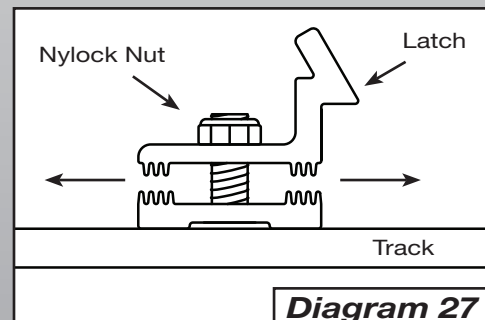

If Lid is tight:

A. Raise Lid and loosen the nylock nut on each Lid Latch Bracket, move the top half of the bracket one notch toward the Housing. Tighten both nuts and close lid (*Diagram 27*). Repeat if further adjustments are needed.