



INSTALLATION GUIDE

2009-CURRENT
HUMMER H3T



PRODUCT CODE:

268



TOOLS NEEDED



COMPONENTS INCLUDED

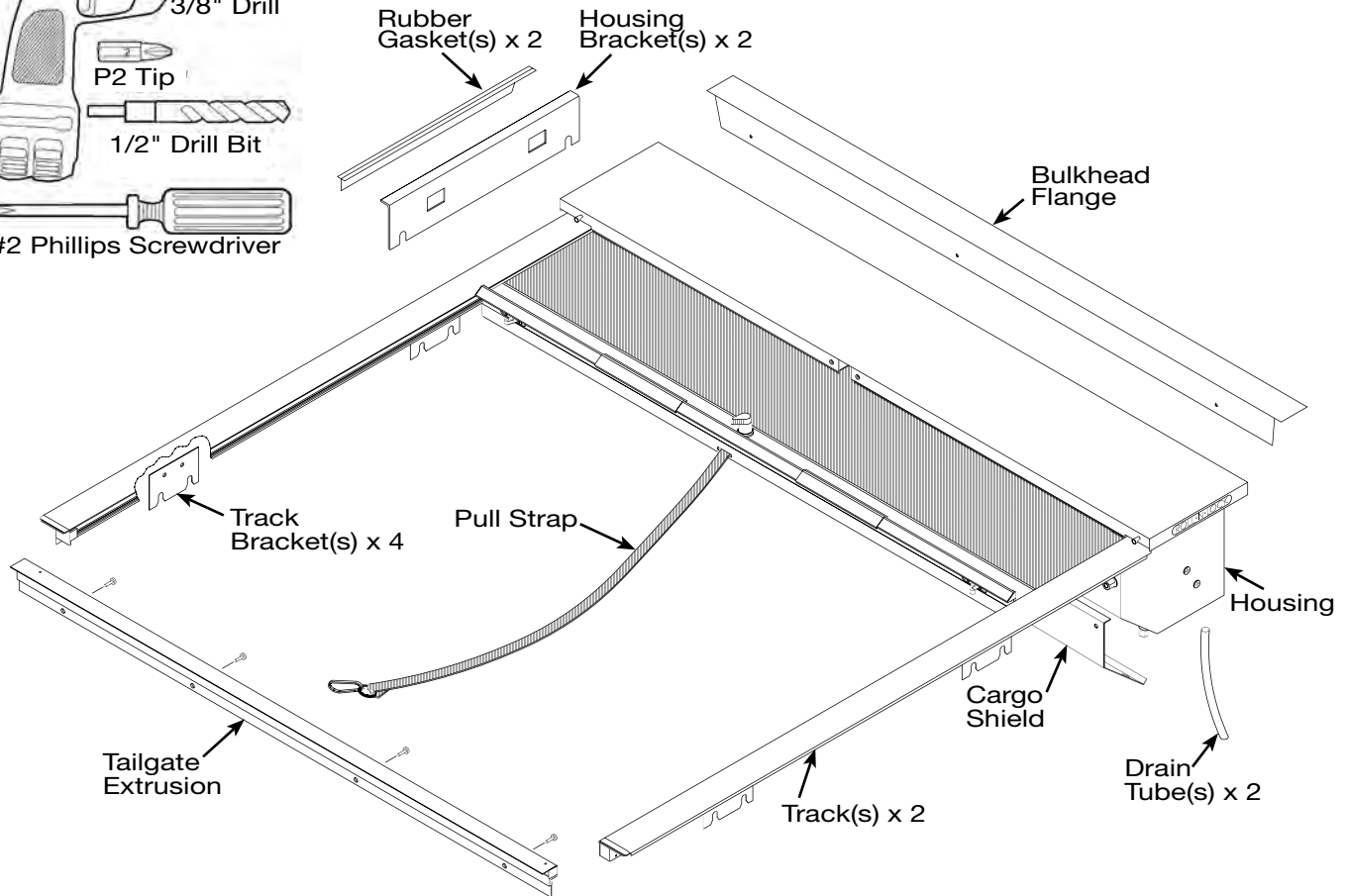

HARDWARE, COMPONENTS & DESCRIPTION



x 10 pieces

(10) 1/4 - 20 Square Nuts, for attachment of Track Brackets and Housing Brackets



x 10 pieces

(10) 1/4 - 20 x 3/4" Truss Head Screw, for attachment of Track Brackets and Housing Bracket



x 10 pieces

(10) 1/4 - 20 Lock Washers, for attachment of Track Brackets and Housing Bracket



x 7 pieces

(7) #8 x 3/4" Self Drilling Button Head Screws, for attachment of Tailgate Extrusion and Housing



(1) Bottle Vinyl Cleaner
(1) Bottle Vinyl Protectant Cleaner, used to remove marks or stains. Protectant should be applied at least monthly.



x 2 pieces

(2) #10 - 24 x 1/2" Truss Head Screws, for attachment of Track to Housing



x 2 pieces

(2) Threaded Tangs (Cargo Nuts) for attachment of Track to Housing



x 4 pieces

(4) 1/4 - 20 x 3/8" Truss Head Screws for attachment of Cargo Shield



x 4 pieces

(4) Rubber Washers for attachment of Cargo Shield



x 3 pieces

(3) 1/4" Black Push Pins for attachment of Bulkhead Flange



STEP 1: INSTALL NUTS & BOLTS FOR BRACKETS

A. Install 1/4-20 x 3/4" bolt, square nut, and lock washer into the holes of the existing cargo management rail system (*Diagram 1*). Locate the bolt in the hole sequence noted (*Diagram 2*).

Note: The # sequence starts at the tailgate and runs towards the cab. Do not fully tighten at this time.

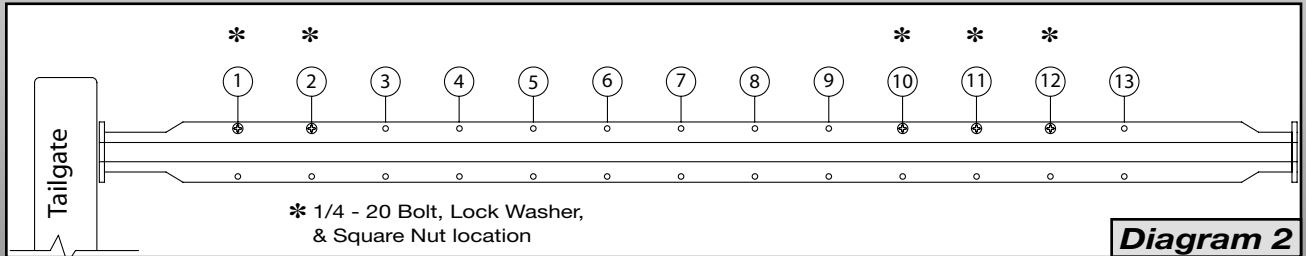
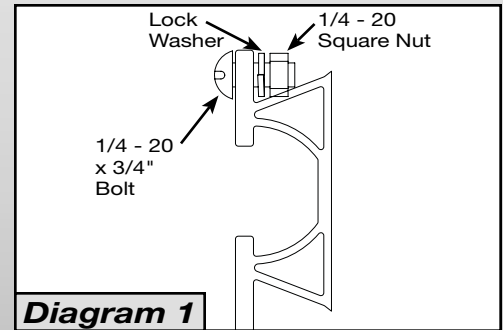

STEP 2: INSTALL HOUSING BRACKETS

A. Slide Housing Bracket over bolt at #12 hole location (*Photo 3*), keeping the Bracket between the cargo management rail and lock washer (*Diagram 4*). Fully tighten and repeat for the other side.

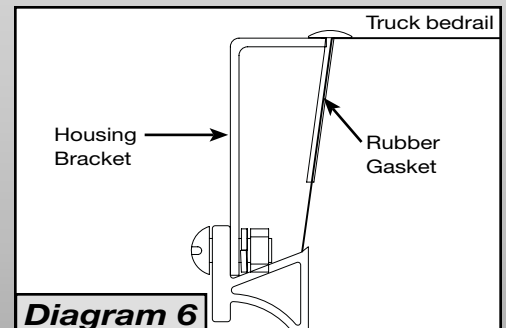
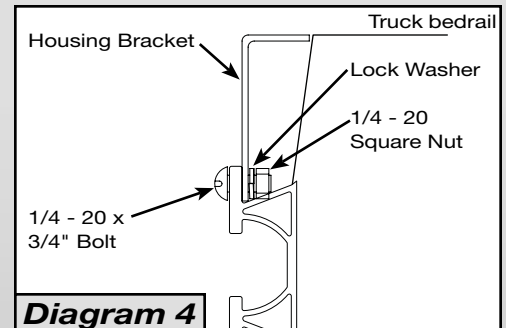
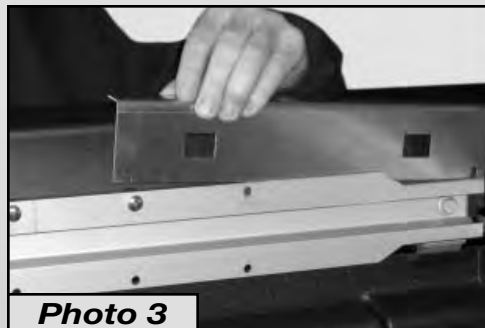

B. Place the small Rubber Gasket (*Photo 5*) provided between the Housing Bracket and the bed rail (*Diagram 6*). **Note: Place the notched end of the gasket on the bulkhead.** Repeat for the other side.

STEP 3: INSTALL THE BULKHEAD FLANGE

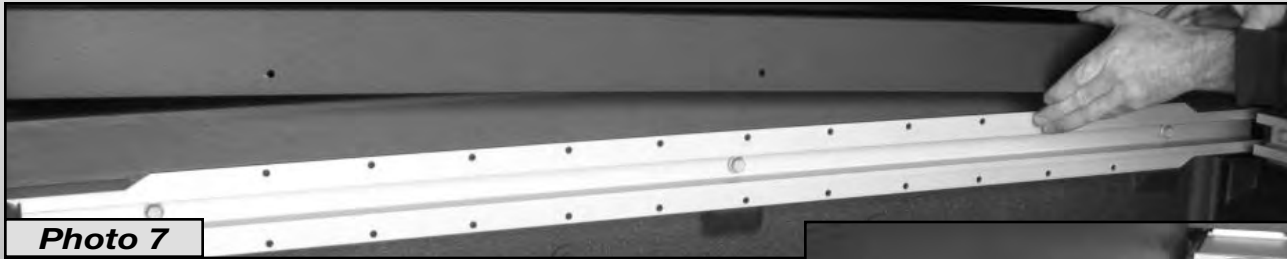

A. Place the Bulkhead Flange over the bulkhead rail (**Photo 7**). Insert the black plastic push-pins to secure the Bulkhead Flange (**Photo 8**).



STEP 4: INSTALL THE HOUSING



A. Place the Housing Assembly onto the Housing Brackets and Bulkhead Flange (**Photo 9**).

STEP 5: INSTALL THE TRACKS



A. Lift the Housing Lid and lean it against the cab (**Photo 10**). Place a rag between the lid and the cab to prevent scratches.

STEP 5: INSTALL THE TRACKS (CONTINUED)

- B.** Making sure to leave the Pull Strap connected to the threaded shipping stud, rotate the Lock Lever to the 10 o'clock position (**Photo 11**).

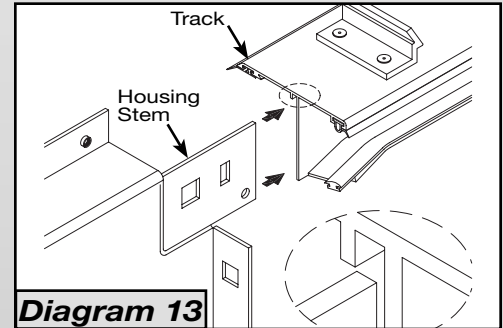

- C.** Carefully place the Tracks on the bedrails (**Photo 12**) and key them onto the Housing Stems (**Diagram 13**), being sure that the Handle is properly engaged into the Tracks.
- D.** Slide the slots in the Track Brackets over the corresponding bolts on the cargo management rail system (**Photo 14**), making sure to keep the Brackets between the bolt head and the cargo management rail.



- E.** Use #10-24 x 1/2" truss head screws and Cargo Nuts to secure the Tracks to the Housing Stems (**Photo 15**). Tighten these connections securely.



STEP 6: POSITIONING THE TRACKS

- A.** Carefully close the tailgate. Push down on the Track (**Photo 16**) so the Track Gasket makes good contact with the top of the bedrail. There should be a slight gap between the Track End Cap and the top of tailgate, so the bottom of the Track End Cap does not rub on the top of the tailgate. Fully tighten the 1/4-20 x 3/4" bolts (**Photo 16**).



STEP 6: POSITIONING THE TRACKS (CONTINUED)

- B.** Loosen **(DO NOT REMOVE)** the [4 #10-24 x 1/2"] Track screws on each Track **(Photo 17)**. Move to the front of the bed, lift up

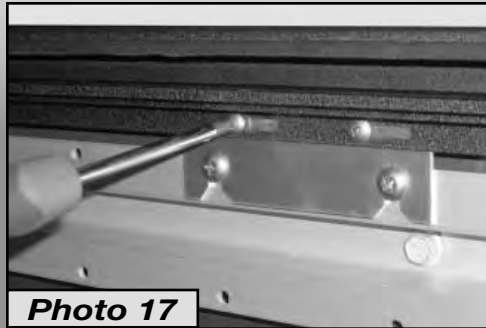

slightly on the Housing and shift each side back toward the tailgate **(Photo 18)** so that the Track End Caps contact the inside surface of the tailgate. Make sure the Track End Cap metal blocks contact the Tailgate Extrusion End Cap.

- C.** Make sure Track height is correct, if adjustments are needed refer to step 6-A.

STEP 7: INSTALL THE TAILGATE EXTRUSION

- A.** With the Tracks installed and the tailgate closed, position the Tailgate Extrusion between the Tracks **(Photo 19)**.



This should be a snug fit. While holding the Tailgate Extrusion in place, use a #8 x 3/4" self tapping screw and power screw gun to secure the center hole **(Photo 20)**.

- B.** Install the remaining self-tapping screws (only 5 needed), making sure to provide even spacing between them. The Tailgate Extrusion should sit snug on top of the tailgate with no gaps.

STEP 8: SECURING THE HOUSING

- A.** Use a #8 x 3/4" self tapping screw and a power screw gun to secure the Housing into the Housing Flange below **(Photo 21)**.



STEP 9: INSTALL CARGO SHIELD & DRAIN TUBES

- A.** Trim the Track Gasket 1" from the end of the Track (**Photo 22**).



- B.** Rotate the Lock Lever to the 7 o'clock position (**Photo 23**), then remove the wing-nut and detach the Pull Strap from the threaded shipping stud (**Photo 24**). Pull the Cover closed and latch it to the tailgate. **NOTE: Do not allow the Cover to retract while the Housing Lid is open.**

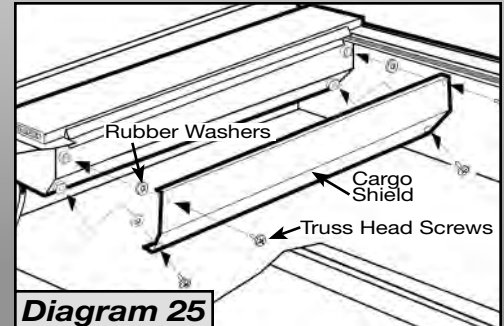

- C.** Before lowering the Housing Lid, turn the Lid Pin Knobs 1/4 turn clockwise, which will cause the pins to pop in if they are not already in. Lower the Housing Lid, being sure that the Lid Pins snap into the receptors located on the Tracks.



- D.** To open the Cover, pull back slightly on the Handle to relieve spring tension from the Latch Mechanisms and turn the Lock Lever clockwise to the 10 o'clock (*unlatched*) position.
- E.** Use 1/4 - 20 x 1/2" truss head screws and rubber washers to secure the Cargo Shield (**Diagram 25**). **Note: The rubber washers go on the inside of the Cargo Shield.**
- F.** Use a 1/2" drill bit to drill holes for the Drain Tubes. Note that this process is easier if a 1/4" pilot hole is drilled first. Align the holes with the Drain Fittings (**Photo 26**). The Drain Tubes made need to be cut to size.
- G.** Always make sure the Pull-Strap is securely clipped to a fixed point in the bed.

STEP 10: TESTING UNIT OPERATION

In Step 9, the Cover was opened (*retracted*). This should have caused the Lock Lever to enter the Lock Pocket and rotate to the 7 o'clock (*latched*) position.

- A. To close the Cover,** pull the Pull-Strap hand-over hand, allowing the excess strap to fall into the bed until you can reach the handle. Place your hands evenly spread on the Handle and pull the Handle until it contacts the Tailgate Extrusion. As the Handle contacts the Tailgate Extrusion the spring loaded Latches (*which were energized when the Cover was retracted*) will automatically trip, simultaneously latching the Cover to the tailgate and side Tracks.
- B. To open the Cover,** pull back slightly on the Handle to relieve spring tension from the Latch Mechanisms and turn the Lock Lever clockwise to the 10 o'clock position. The Cover should retract on its own with only a slight push to set it into motion. When the Cover is retracting it is best to hold the Pull-Strap and allow it to slip through your fingers as the Cover travels. Applying pressure to the Pull-Strap as it slips through your fingers will act as a braking action preventing the Handle from slamming into the Housing Lid at high speed. The Cover must retract with only enough force to rotate and reset the Lock Lever and Latching Mechanisms.

STEP 11: INSTRUCTIONS FOR OPENING AND CLOSING THE HINGED LID

To Open:

- A.** Grasp the Latch Pin Knobs located at the back corners of the Housing Lid (*Diagram 27*) and pull out.
- B.** Turn knobs 90° to hold latch in the unlocked position (*Diagram 28*).
- C.** Grasp the Housing Lid and lift (*Diagram 29*). Rest the Lid against the back of the cab to hold it open for service or cleaning.

To Close:

- A.** Reverse the previous steps. Lower the Lid and return the latch to the locked position by turning the knob 90°. **NOTE: The Latch Pin Knob may be returned to the locked position before or after closing the lid.**

