



# Installation Guide

2008 - Current  
Ford F-250 & Ford F-350 Super Duty



**Product Code:  
109 & 119**

## Tools Needed

## Components Included

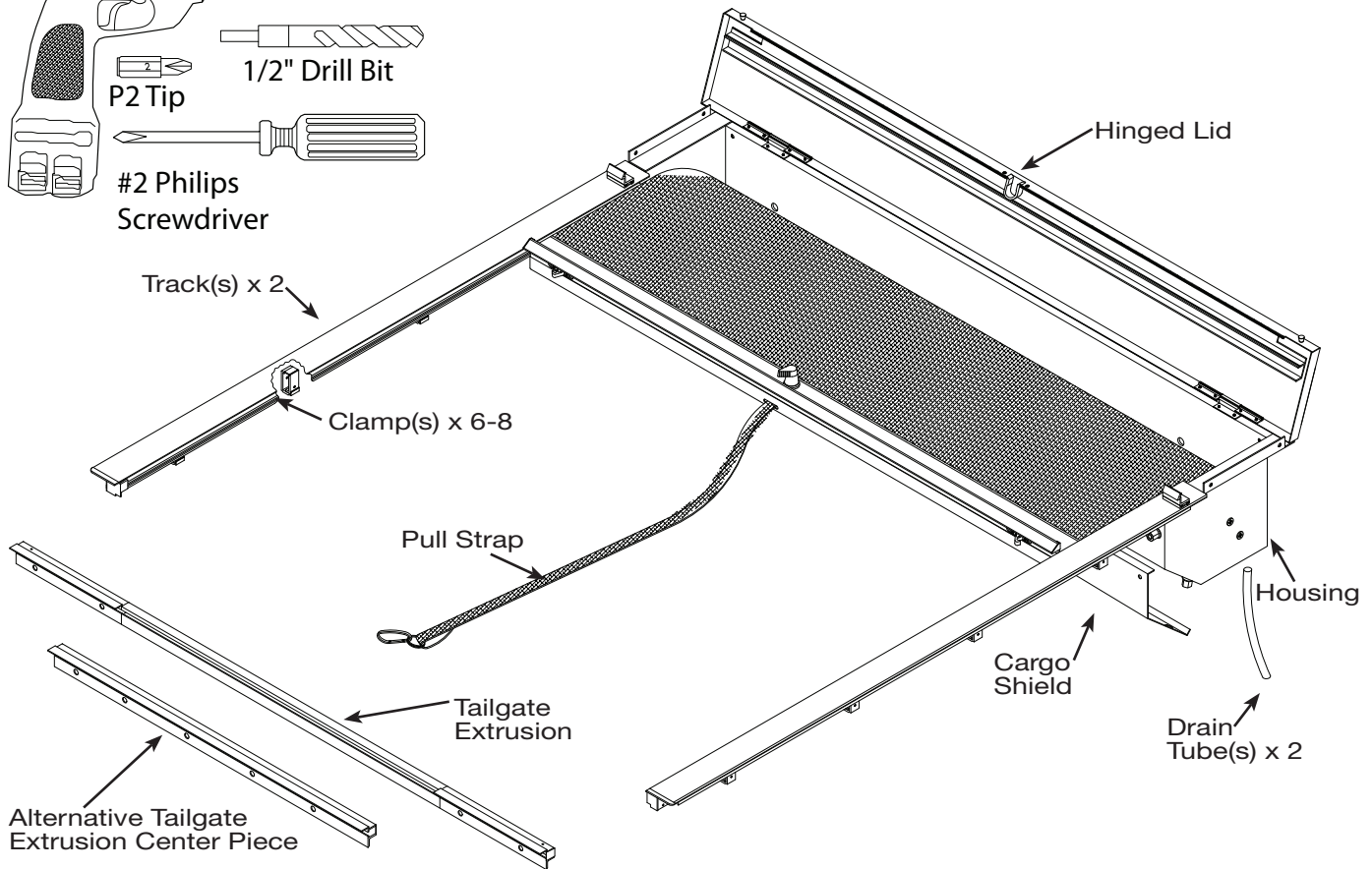
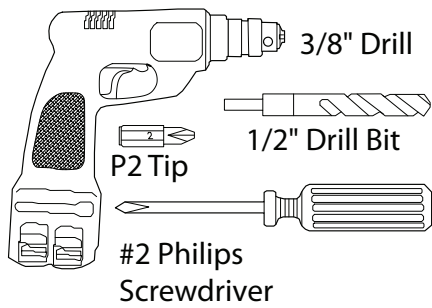

# STOP!

If you have a plastic drop-in bedliner, be sure to follow Step 1 on the next page.

If no bedliner is present, proceed to Step 2



# Step 1: Bedliner Modification

**Note:** If the truck is equipped with a plastic drop-in bedliner and/or a plastic tailgate protector, some alteration will be necessary. **If no bedliner is present skip step 1A and proceed to 1B.**

The dotted lines (**Diagram 1**) depict the under-the-rail liner modifications.

- A.** Remove the bedliner from the truck and using a jig saw with a medium tooth blade, remove the bulkhead portion of the liner as indicated. Replace the bedliner in the truck.
- B.** If the tailgate has no plastic protector panel; remove the metal access panel and proceed to **Step 2**. If the tailgate has a plastic protector panel; remove the panel and, if present, remove and set aside the metal access panel. Mark a straight cut line  $1\frac{1}{4}$ " from the top of the **plastic** panel (**Diagram 2 or 2a**). Carefully make a straight cut and remove the portion from the **plastic** tailgate panel. **Do not replace the plastic or metal panel at this time. Replace in Step 6 as indicated.**

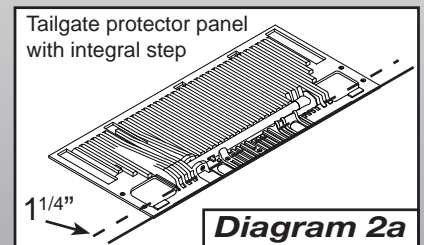
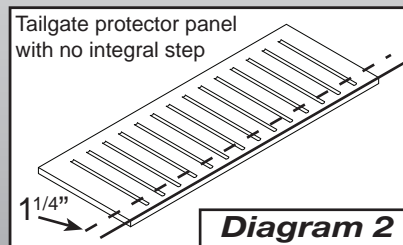
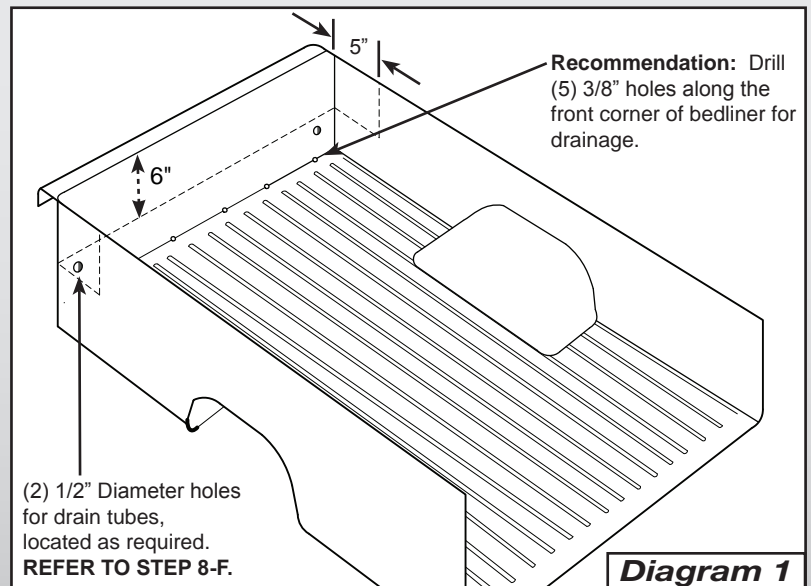

# Step 2: Notching Factory Bedrail Caps

**Note:** This modification is required to ensure proper functioning of the Latching Mechanism.

- A.** Measure 3" from the outside edge and place a vertical mark of the down-flange of the bedrail cap. It is also advisable to mark a horizontal cutting line along the top edge of the bedrail cap (**Diagram 3**).
- B.** Slip a supplied metal Stake Pocket Cover between the bedrail cap and the painted bedrail to prevent scratching the paint when cutting. Carefully use a utility knife to notch the bedrail cap, and remember to always cut away from your body.

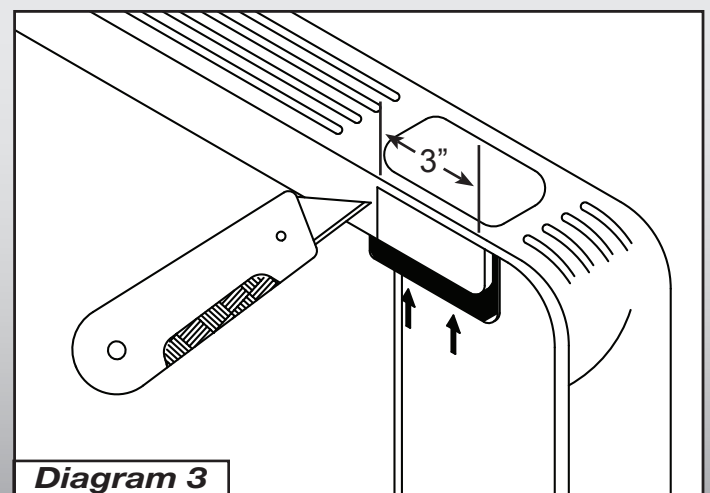

# Step 3: Install the Housing

- A. Place the Housing Assembly on the bedrails (**Diagram 4**). This is best accomplished with two people. Center the Housing between the bedrails with the back of the Housing up against the bulkhead. **Do not fasten the Housing in place.**

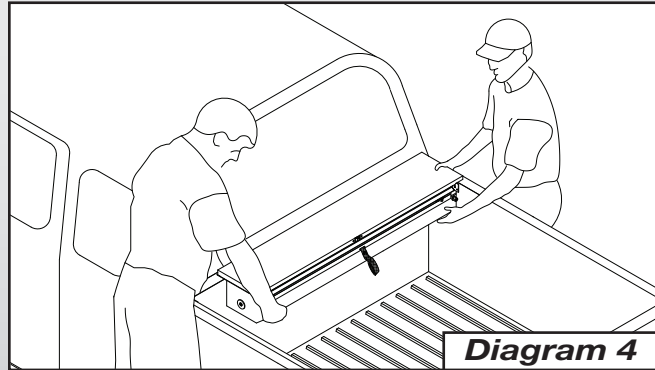

- B. Lift the Lid on the Housing and lean it against the cab (**Diagram 5**). Place a rag between the Lid and cab to prevent scratches.

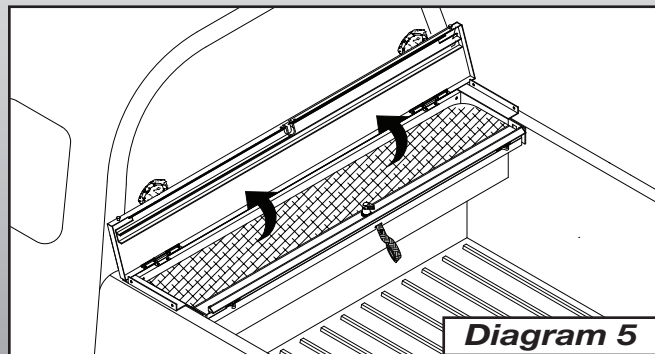

# Step 4: Install the Tracks

- A. Making sure to leave the Pull Strap connected to the Shipping Stud, rotate the Lock Lever to the 10 o'clock position (**Diagram 6**).

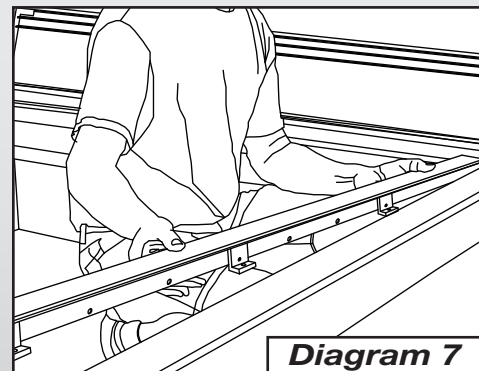
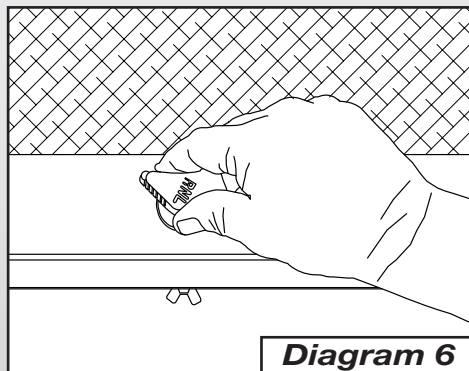

- B. Unwrap the Tracks and locate the supplied Bed Clamps that are taped together along with the bolts and washers. Unwrap the Clamps and set them in the bed of the truck. Carefully place the Tracks on the bedrails (**Diagram 7**) and key them onto the Housing Stems (**Diagram 8**), being sure that the Handle is properly engaged into the Tracks.

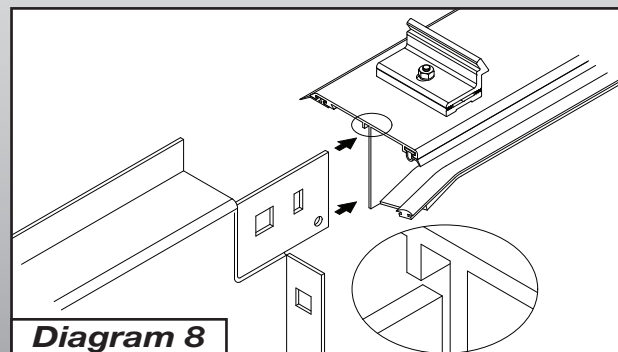

# Step 4: Install the Tracks (Cont.)

- C. Attach the back Clamps very loosely to the Tracks to be sure that the Tracks do not fall off of the bed rail while proceeding (*Diagram 9*).

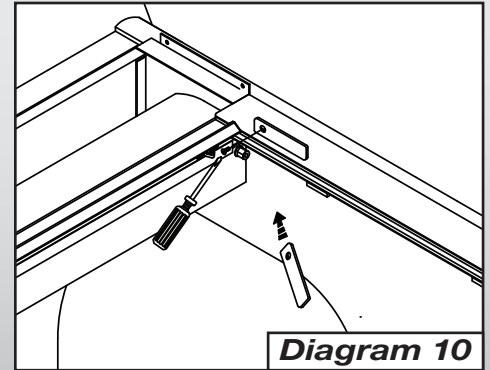
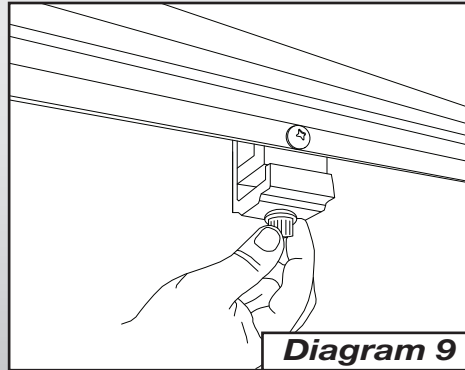

- D. Use the #10-24 x 1/2" truss head screws and Cargo Nuts supplied to secure the Tracks to the Housing Stems (*Diagram 10*). Tighten these connections securely.
- E. Attach the remaining Clamps very loosely. **Do not tighten yet.**

**STOP:** IF THE TAILGATE IS EQUIPPED WITH AN INTEGRAL TAILGATE STEP PROCEED TO STEP 6: INSTALL THE TAILGATE EXTRUSION

## Step 5: Modification of the Tailgate Extrusion with No Integral Step

- A. An alternative center section ("D") for the tailgate extrusion has been supplied for trucks with no integral step. Using the allen wrench provided loosen the set screws and remove the joining block (*Diagram 11*). Repeat for the other side. Discard the shims and the center section ("C") tailgate piece.

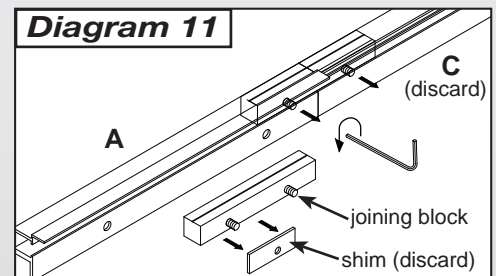

- B. Place the shim provided over the set screws and insert the joining block back 1/2 way into tailgate piece ("A") (*Diagram 12*) tighten set screw. Make sure the locking pin is on the opposite end of the joining block. Repeat for tailgate piece ("B").

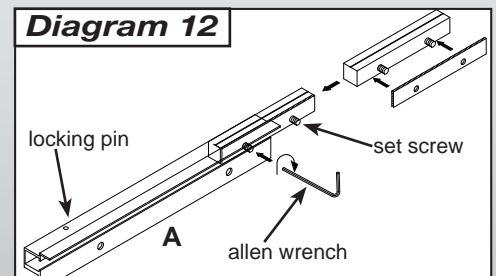

- C. Slide the supplied alternative center tailgate piece ("D") onto tailgate piece "A" and "B". Making sure there is a snug fit; tighten the 4 set screws (*Diagram 13*).

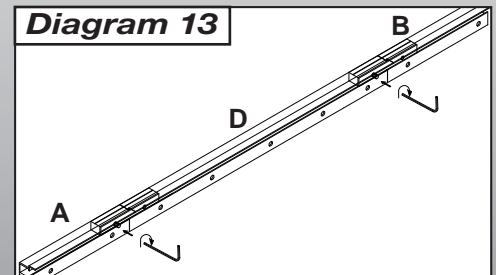

# Step 6: Install the Tailgate Extrusion

- A. Lower the tailgate and use a tape measure to center the Tailgate Extrusion onto the tailgate.
- B. While holding the Tailgate Extrusion square and centered on the tailgate, use the self-taping screws provided and a power screw gun secure the Tailgate Extrusion to the tailgate (*Diagram 14*).  
**Note:** If tailgate has the integral tailgate step use 2 fasteners on each end to secure the Tailgate Extrusion. If tailgate has no integral step an additional fastener in the center of the Tailgate Extrusion can be used.
- C. Replace the metal tailgate access panel (if applicable) and the plastic tailgate protector panel, secure to the tailgate. **Note:** A portion of the metal tailgate panel will overlap the Tailgate Extrusion (*Diagram 15*).
- D. With the Tailgate Extrusion secured, carefully close the tailgate, being cautious not to strike the ends of the Tracks.

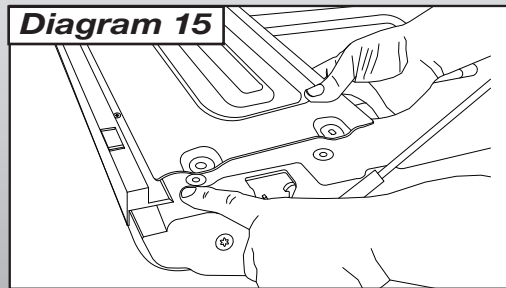
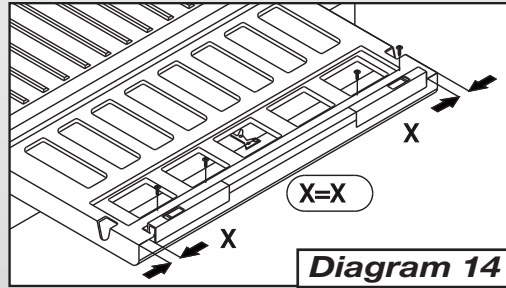

# Step 7: Orienting the Tracks to the Tailgate

- A. Move to the front of the bed, lift up slightly on the Housing and shift each side back toward the tailgate (*Diagram 16*) so that the Track End-Caps contact the inside surface of the tailgate. Make sure the Track End Cap Metal Blocks contact the Tailgate Extrusion End Caps (*Diagram 17*). **Note that if the Tracks are not positioned as shown, the Latch Mechanism will not function correctly.**
- B. With the Tracks in the correct position, you may now tighten the Clamps in the order shown (*Diagram 18*) taking care to make sure the Tracks remain level. **Do not use a power or pneumatic screw gun. Over tightening Track Clamps can cause an indentation in the bedrails**
- C. If the Track pitches upward, loosen the Clamp, rotate the Track level and install the optional Angularity Adjustment Screw as shown (*Diagram 19*). Tighten the screw until it biases against the bedrail down-flange as shown

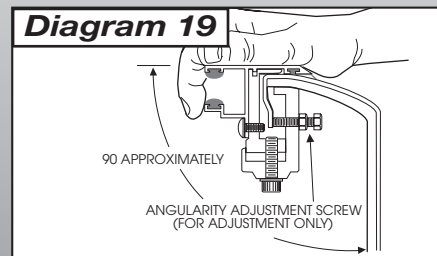
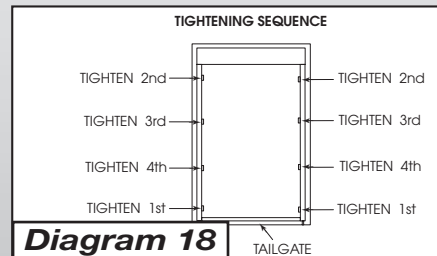
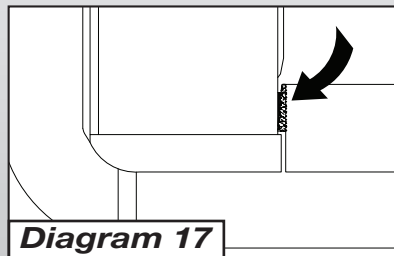
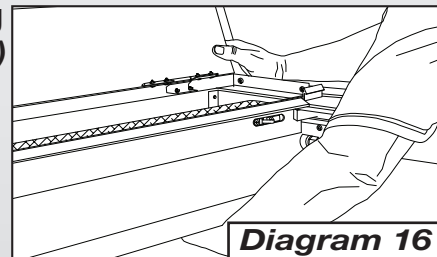

# Step 8: Install Cargo Shield & Drain Tubes

- A. Trim the track gasket 1" from the end of the Track (**Diagram 20**).
- B. Rotate the Lock Lever to the 7 o'clock (*closed*) position (**Diagram 21**), then remove the plastic wing nut and detach the Pull Strap from the threaded Stud (**Diagram 22**). Pull the Cover closed and latch it to the tailgate.

**Note: Do not allow the Cover to retract while the Housing Lid is open.**

- C. Before lowering the Housing Lid, turn the Lid Pin Knobs 1/4 turn clockwise, which will cause the pins to pop in if they are not already. Lower the Housing Lid, being sure that the Lid Pins snap into the receptors located on the Tracks.

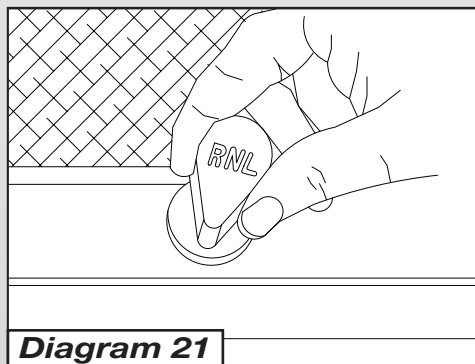

- D. To open the Cover pull back slightly on the Handle to relieve spring tension from the Latch Mechanisms and turn the Lock Lever clockwise to the 10 o'clock (*unlatched*) position, while holding the pull strap allow the Cover to retract back into the housing with just enough force to reset the Lock Lever.

- E. Use the 14-20 x 1/2" truss head screws and rubber washers supplied to secure the Cargo Shield (**Diagram 23**).

**Note: The rubber washers go on the inside of the Cargo Shield.**

- F. Use the 1/2" bit to drill 2 holes for Drain Tubes. Note that this process is easier if a 1/4" pilot hole is drilled first. Align the holes with the Drain Fittings that protrude from the bottom of the Housing Assembly (**Diagram 24**). If provided, locate the Drain Tubes in factory drain holes or bulkhead plugs.

- G. Always make sure the Pull-Strap is securely clipped to a fixed point in the bed.

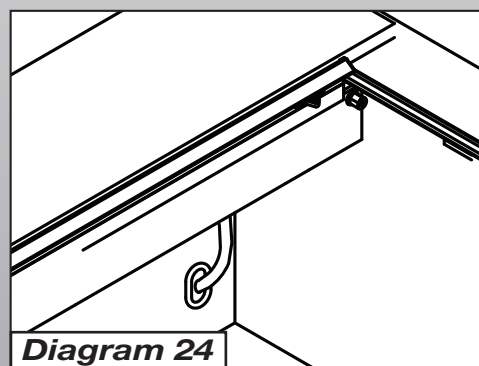
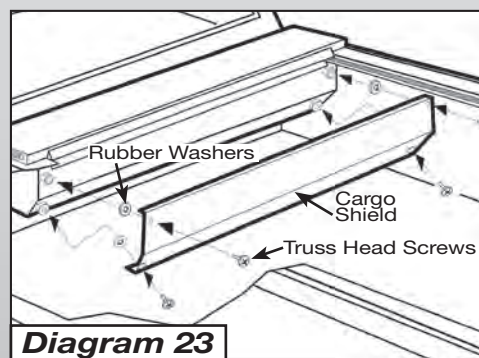
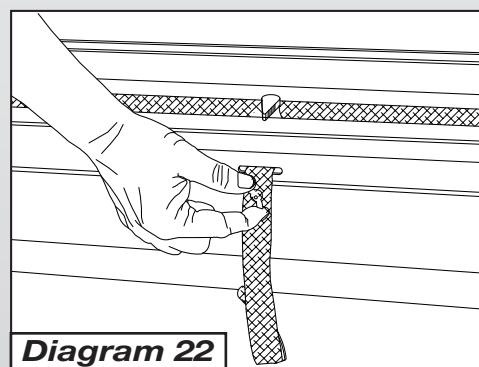
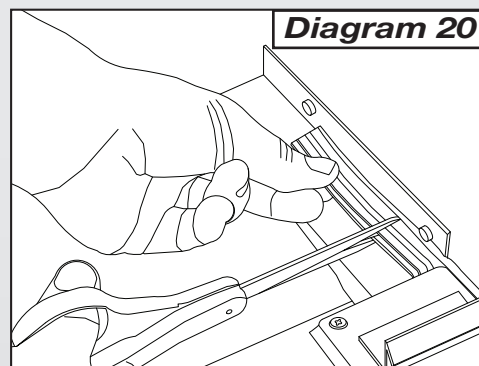

## Step 9: Test Unit Operation

In Step 6 the Cover was opened (*retracted*). This should have caused the Lock Lever to enter the Lock Pocket and rotate to the 7 o'clock (*latched*) position.

- A. To close the Cover**, pull the Pull-Strap hand-over hand, allowing the excess strap to fall into the bed until you can reach the Handle. Place your hands evenly spread on the Handle and pull the Handle until it contacts the Tailgate Extrusion. As the Handle contact the Tailgate Extrusion the spring loaded Latches (*which were energized when the Cover was retracted*) will automatically trip, simultaneously latching the Cover to the tailgate and side Tracks.
- B. To open the Cover**, pull back slightly on the Handle to relieve spring tension from the Latch Mechanisms and turn the Lock Lever clockwise to the 10 o'clock position. The Cover should retract on it's own with only a slight push to set it into motion. When the Cover is retracting it is best to hold the Pull-Strap and allow it to slip through your fingers as the Cover travels. Applying pressure to the Pull-Strap as it slips through your fingers will act as a braking action, preventing the Handle from slamming into the Lid at high speed. The Cover must retract with only enough force to rotate and reset the Lock Lever and Latching Mechanism

## Step 10: Opening and Closing / Adjusting the Hinged Lid

### To Open:

- A.** Grasp the Latch Pin Knobs, pull out and turn knobs 90° to hold Pin in the unlock position. Grasp the Lid and lift. Rest the Lid against the back of the cab to hold open for service or cleaning (**Diagram 25**).

### To Close:

- A.** Lower the Lid and return the Latch Pins to locked position by turning the knobs 1/4 turn.

### If Lid is loose:

- A.** Raise Lid and loosen the nylock nut on each Lid Latch Bracket, move the top half of the Bracket one notch toward the tailgate. Tighten both nuts and close Lid (**Diagram 26**).

### If Lid is tight:

- A.** Raise Lid and loosen the nylock nut on each Lid Latch Bracket, move the top half of the Bracket one notch toward the Housing. Tighten both nuts and close Lid (**Diagram 26**). Repeat if further adjustments are needed.

