

Original Instructions

Model: 34288NI



Recover, Recycle, Recharge Machine
for R-134a A/C Systems

Table of Contents

Safety Precautions	2	Maintenance	19
Explanation of Safety Signal Words	2	Maintenance Schedule	19
Explanation of Safety Decals	2	Load Language	20
Protective Devices	4	Tank Fill	21
Refrigerant Tank Test	4	Filter Maintenance	22
		Check Remaining Filter Capacity	22
Introduction	5	Replace the Filter	23
Technical Specifications	5	Calibration Check	24
Features	6	Change Vacuum Pump Oil	25
Control Panel Functions	8	Leak Check	26
Icon Legend	9	Edit Print Header	27
Setup Menu Functions	10	Replace Printer Paper	27
		Install a Printer	28
Initial Setup	11	A/C Service Function	29
Unpack the Machine	11	Replacement Parts	29
Unpack the Accessory Kit	11	Glossary	29
Install the Oil Drain Bottle	11		
Power Up the Machine	11	Troubleshooting	30
Select Language	12		
Select Units	12	Storage and Transportation of Equipment ...	33
Set Date and Time	12	Storage	33
Edit Print Header	12	Transportation of Equipment	33
Service Vacuum	13		
Tank Fill	13	Disposal of Equipment	34
Unit Activation	14	Disposal of Recycled Materials	34
		Disposal of the Machine	34
Operating Instructions	15	Disposal of Batteries	34
Recover Refrigerant from a Vehicle	15		
Evacuate the Vehicle A/C System	16		
Recharge the Vehicle A/C System	17		
Automatic Function	18		

Safety Precautions

Explanation of Safety Signal Words Used in this Manual

The safety signal word designates the degree, or level, of hazard seriousness.

 **DANGER:** Indicates an imminently hazardous situation which, if not avoided, will result in death or serious injury.

 **WARNING:** Indicates a potentially hazardous situation which, if not avoided, could result in death or serious injury.

 **CAUTION:** Indicates a potentially hazardous situation which, if not avoided, could result in minor or moderate injury.

CAUTION: Used without the safety alert symbol indicates a potentially hazardous situation which, if not avoided, could result in property damage.

These safety messages cover situations Robinair is aware of. Robinair cannot know, evaluate, or advise as to all possible hazards. The user must verify that conditions and procedures do not jeopardize personal safety.

Explanation of Safety Decals Used on the Machine

	Carefully read the instructions.
	Do not use in open air in case of rain or high humidity.
	Wear gloves.
	Wear protection goggles.
	Alternating voltage.
	Grounding protection.
	Electrical shock hazard.

Safety Precautions



WARNING: To prevent personal injury,



ALLOW ONLY QUALIFIED PERSONNEL TO OPERATE THE MACHINE. Before operating the machine, read and follow the instructions and warnings in this manual. The operator must be familiar with air conditioning and refrigeration systems, refrigerants, and the dangers of pressurized components. If the operator cannot read this manual, operating instructions and safety precautions must be read and discussed in the operator's native language.



USE THE MACHINE AS OUTLINED IN THIS MANUAL. Using the machine in a manner for which it was not designed will compromise the machine and nullify the protections provided.



PRESSURIZED TANK CONTAINS LIQUID REFRIGERANT. Do not overfill the internal storage vessel (ISV). Overfilling can cause explosion resulting in personal injury or death. Do not recover refrigerants into nonrefillable containers; use only type-approved refillable containers that have pressure relief valves.



HOSES CAN CONTAIN LIQUID REFRIGERANT UNDER PRESSURE. Contact with refrigerant can cause personal injury, including blindness and frozen skin. Wear protective equipment, including goggles and gloves. Disconnect hoses using extreme caution. Ensure the phase is complete before disconnecting the machine to prevent the release of refrigeration to the atmosphere.



AVOID BREATHING A/C REFRIGERANT AND LUBRICANT VAPOR OR MIST. Exposure can irritate eyes, nose, and throat. To remove refrigerant from the A/C system, use only equipment certified for the type of refrigerant being removed. Use the unit in locations with mechanical ventilation that provides at least four air changes per hour. If accidental system discharge occurs, ventilate the work area before resuming service.

DO NOT DISPERSE REFRIGERANT INTO THE ENVIRONMENT. Prevent the possible presence of refrigerant in the working environment.



TO REDUCE THE RISK OF FIRE, do not use the machine in the vicinity of spilled or open containers of gasoline or other flammable substances.

TO REDUCE THE RISK OF FIRE, do not use an extension cord. An extension cord can overheat and cause fire. If an extension cord must be used, use the shortest possible cord with a minimum size of 14 AWG.

TO REDUCE THE RISK OF FIRE, do not use the machine in the vicinity of flames and hot surfaces. Refrigerant can decompose at high temperatures and free toxic substances to the environment that can be noxious to the user.

TO REDUCE THE RISK OF FIRE, do not use the machine in environments containing explosive gases or vapors.

TO REDUCE THE RISK OF FIRE, do not use this machine in ATEX classified zones or areas. Protect the machine from conditions that can cause electrical failure or other hazards relating to ambient interaction.



CAUTION—DO NOT PRESSURE TEST OR LEAK TEST EQUIPMENT AND/OR VEHICLE AIR CONDITIONING SYSTEMS WITH COMPRESSED AIR. Mixtures of air and R-134a refrigerant can be combustible at elevated pressures. These mixtures are potentially dangerous and can result in fire or explosion causing personal injury and/or property damage.



HIGH VOLTAGE ELECTRICITY INSIDE THE MACHINE HAS A RISK OF ELECTRICAL SHOCK. Exposure can cause personal injury. Disconnect power before servicing the machine.

NEVER LEAVE THE MACHINE LIVE IF AN IMMEDIATE USE IS NOT SCHEDULED. Disconnect the electrical supply before a long period of inactivity or before internal maintenance is performed.

DO NOT MODIFY THE PRESSURE RELIEF VALVE OR CHANGE THE CONTROL SYSTEM SETTINGS. Using the machine in a manner for which it was not designed will compromise the machine and nullify the protections provided.

**Additional health and safety information can be obtained
from refrigerant and lubricant manufacturers.**

Safety Precautions

CAUTION : To prevent equipment damage,



TO PREVENT CROSS-CONTAMINATION, USE THIS MACHINE WITH R-134A REFRIGERANT ONLY.

The machine is equipped with special connectors to recover, recycle, and recharge only R-134a refrigerant. Do not attempt to adapt the machine for another refrigerant. Do not mix refrigerant types through a system or in the same container; mixing of refrigerants will cause severe damage to the machine and the vehicle air conditioning system.

DO NOT USE THIS MACHINE IN DIRECT SUNLIGHT. Position the machine far from heat sources, such as direct sunlight, which can cause excessive temperatures. The use of this machine under normal environmental conditions (10°C to 50°C) keeps pressures under reasonable limits.



DO NOT USE THIS MACHINE OUTDOORS DURING RAIN OR HIGH HUMIDITY. Protect the machine from conditions that can cause electrical failure or other hazards relating to ambient interaction.

DO NOT USE THIS MACHINE IN AREAS WHERE THERE IS A RISK OF EXPLOSION.

SET UP THE MACHINE ON AN EVEN SURFACE AND UNDER SUFFICIENT LIGHTING. LOCK THE FRONT WHEELS, AND DO NOT SUBJECT THE MACHINE TO VIBRATION.

TO AVOID CHEMICAL INCOMPATIBILITIES WITH THE INTERNAL COMPONENTS OF THE MACHINE, USE ONLY OILS APPROVED BY THE VEHICLE MANUFACTURER. Problems resulting from the use of non-approved oils will void the warranty.

Additional health and safety information can be obtained from refrigerant and lubricant manufacturers.

Protective Devices

The machine is equipped with the following protective devices:

- Over pressure valves.
- A maximum pressure switch stops the compressor when excessive pressure is sensed.



WARNING: Tampering with these protective devices could result in serious injury.

Refrigerant Tank Test

Official records and recurring tests necessary for pressurized instruments are governed by laws and/or national regulations dependent upon the country where the refrigerant tank is used. The system manager is responsible for compliance with laws, regulations, and technical rules. During normal service, refrigerant tanks do not need maintenance. Refer to the Maintenance section of this manual for more information.

This machine is used on R-134a equipped vehicles and is designed to be compatible with existing service equipment and standard service procedures. This machine is a single-pass system (i.e. refrigerant flows through a filter once) that meets specifications for recycled refrigerant. Follow recommended service procedures for the containment of R-134a.

Note: Refrigerant systems require special oils. Refer to the A/C system manufacturer's service manual for oil specifications.



Technical Specifications

Dimensions	107 cm x 61 cm x 76 cm
Display	5 × 9 cm (4.3-in. diag) graphical LCD
Filter Life Capacity	68 kg (150 lb)
Humidity	32.2°C (90°F), 80% RH non-condensing
Manometers	Ø 80 mm (3.15 in.)
Maximum Pressure	27.3 bar (396 PSI)
Noise	<70 dB(A)
Nominal Voltage	115V, 60 Hz
Oil Drain Bottle Capacity	355 ml (12 oz)
Operating Temperature	10°C to 50°C (50°F to 122°F)
Power Consumption	1380 VA
Vacuum Pump Free-Air Displacement	1.5 CFM (42 L/m) @ 60 Hz
Service Hoses	2.75 m (9 ft) / SAE J2196
Tank Capacity	10 kg (22 lb)
Weight	73 kg (161 lb)

Introduction

Features

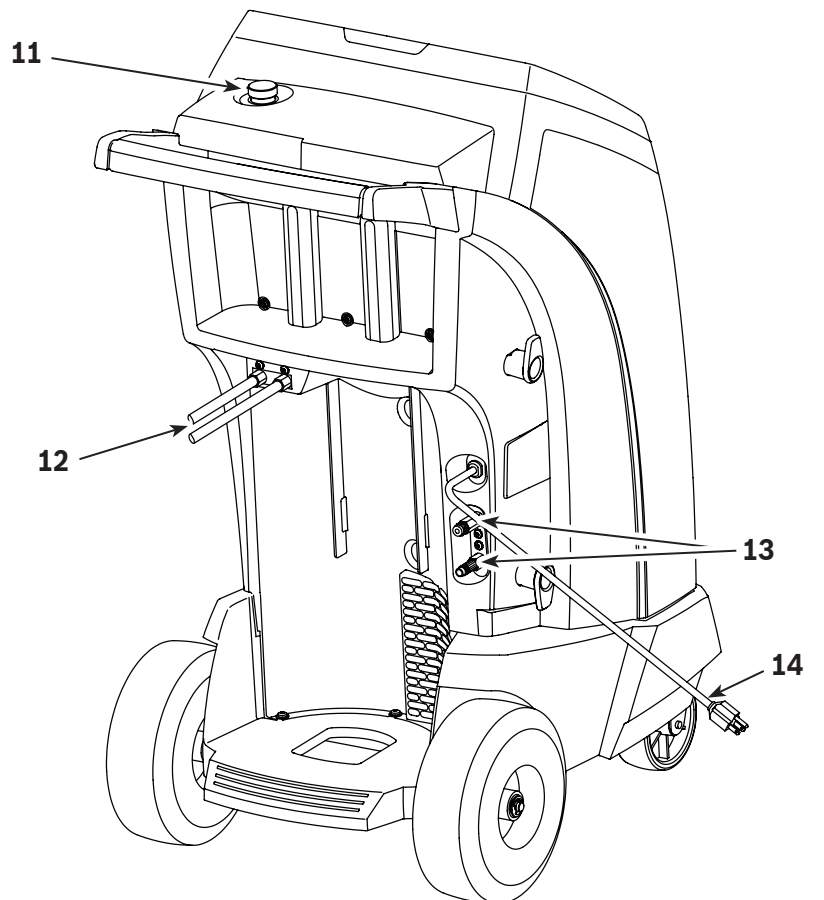
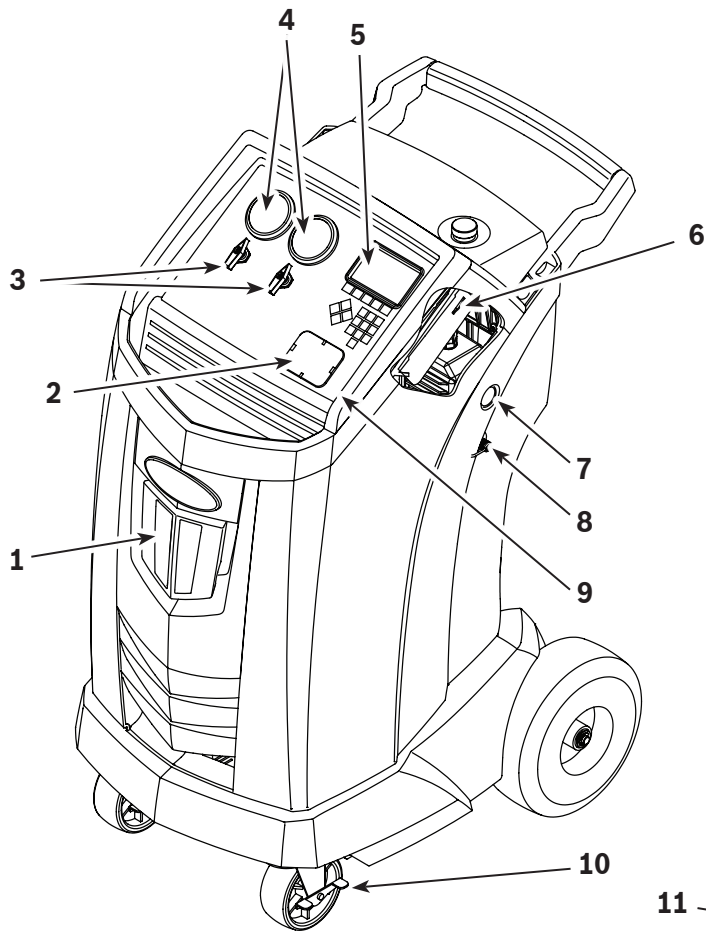

Item No.	Description
1	Oil Drain Bottle
2	Printer Cap (printer sold separately)
3	Panel Valves
4	Low-side (blue) and High-side (red) Manifold Gauges
5	Graphic Display and Keypad
6	SD Card Connection
7	Vacuum Pump Oil Sight Glass
8	Vacuum Pump Oil Drain Fitting
9	Power Switch
10	Wheel Lock
11	Vacuum Pump Oil Fill Cap and Port
12	Service Hoses
13	Service Hose Storage Ports
14	Power Cord

Introduction

Control Panel Functions

- ARROW UP** highlights the previous item.
- ARROW DOWN** highlights the following item.
- ARROW RIGHT** scrolls to next screen.
- ARROW LEFT** scrolls to previous screen.
- SELECTION ARROWS** make a selection or answer a query.

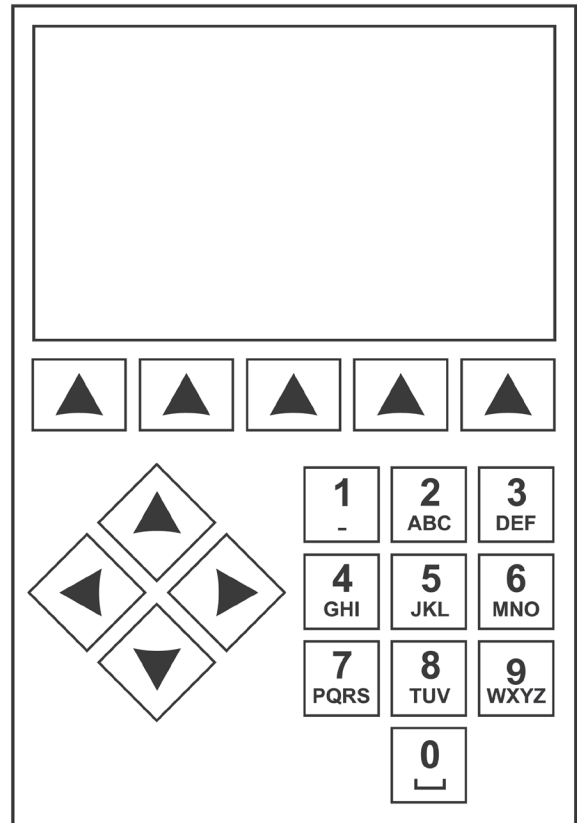

Control Panel Keypad

Icon Legend



AUTOMATIC ICON

Pressing the key under this icon will enter the automatic refrigerant recovery, vacuum, and charge process.



RECOVER ICON

Pressing the key under this icon will enter the refrigerant recovery process.



VACUUM ICON

Pressing the key under this icon will enter the system vacuum process.



CHARGE ICON

Pressing the key under this icon will enter the refrigerant charge process.



NEXT/FORWARD ICON

Pressing the key under this icon will proceed to additional menu selection options, or proceed to an additional step in a function or process.



BACK ICON

Pressing the key under this icon will return to previously seen menu selection options, or return to the previous screen within a function or process.



HELP ICON

Pressing the key under this icon will provide help and information corresponding to the current screen and/or function being viewed or performed.



DATABASE ICON

Pressing the key under this icon will enter the vehicle database retrieval process.



SETUP MENU ICON

Pressing the key under this icon will enter the Setup Menu.



YES/ACCEPT ICON

Pressing the key under this icon will accept any choices made on the current screen and proceed to the next step of the function.



NO/CLOSE ICON

Pressing the key under this icon will reject any choices made on the current screen and return to the previous step of the function or the Main Menu.



RETRY ICON

Pressing the key under this icon will retry the current process or function.



CHARGE PATH SELECTION ICON

Pressing the key under this icon will toggle the desired path of refrigerant charge between high side, low side, and both side.



ON/OFF ICON

Pressing the key under this icon will toggle the highlighted function on or off as desired.



BACKSPACE ICON

Pressing the key under this icon will delete a text character to the left of the current selection.



PAUSE ICON

Pressing the key under this icon will pause the current process.



RESUME ICON

Pressing the key under this icon will resume a process that has been paused.



PRINT ICON

Pressing the key under this icon will print a summary corresponding to the current completed process.



DELETE ICON

Pressing the key under this icon will delete a selected entry from the memory of the machine.



CHANGE UNITS ICONS



Pressing the key under one of these icons will toggle the unit of measurement for the current entry field.

Introduction

Setup Menu Functions

Access the following functions by pressing the Menu key and selecting Setup.

Select Language

Select a language for screen prompts. English is the default language.

Hose Equalize

Use this Setup Menu item to recover refrigerant from the service hoses back into the vehicle A/C system. This item is useful after performing diagnostics which do not require the need to recover the A/C system into the RRR machine. The user will be prompted to connect the low side service hose to the appropriate port and to start the vehicle's A/C system on max.

Tank Fill

Use this Setup Menu item to transfer refrigerant from a source tank to the ISV. The tank fill amount may be adjusted up or down to suit the user's needs. Refer to Tank Fill in the Maintenance section.

Refrigerant Tracking

If enabled, the machine will retain records of refrigerant that has been recovered, charged, and replenished (filled from source tank). This data can be exported to SD card or printed (if printer is installed).

Refrigerant Management

Displays the amount of refrigerant recovered, charged, and replenished (for the life of the machine), and filtered since the last filter change.

Filter Maintenance

The filter removes acid, particulates, and moisture from the refrigerant. To meet requirements, it is mandatory to replace the filter after 68 kg (150 lb) of refrigerant has been filtered.

This menu item displays the filter capacity remaining until the machine locks down and no longer functions. Refer to Filter Maintenance in the Maintenance section.

Pump Maintenance

Displays the amount of time remaining until the next vacuum pump oil change is needed. For maximum vacuum pump performance, change vacuum pump oil every time the filter is replaced. Refer to Change Vacuum Pump Oil in the Maintenance section.

Calibration Check

Use to verify internal scale calibration. Refer to Calibration Check in the Maintenance section of this user manual.

ISV Purge Condition

Displays the temperature and pressure of the internal tank.

Display Title Info

Enables/Disables diagnostic information of the machine to be displayed on the title bar of the display.

Leak Check

Initiates a leak check on the machine.

Select Units

Program the machine to display units of measure in kilograms or pounds. The default display is kilograms.

Date and Time

Program the machine for current date and time.

Edit Print Header

Programs information that will appear on the printout each time a print function is used.

Replace Service Hoses

Initiates the set of actions required to replace the service hoses.

Default Vacuum Time

Allows user to modify the machine's default setting.

Unit Activation

Failure to register and activate the machine within 30 days of initial startup will cause the machine to lock out and no longer function. Select this Setup Menu item and follow the prompts before the trial period expires.

System Information

Displays the revision level of the software in the machine.

Service Menu

For Robinair service center use only.

Production Menu

For Robinair production use only.

Unpack the Machine



1. Remove the bandings from the box.
2. Remove the top carton infold, the molded pulp tray, and the angle boards.
3. Remove the sleeve from the bottom carton infold.
4. Gently roll the unit forward and off the pallet, avoiding any sudden shocks to the machine.



WARNING: To prevent personal injury while working with refrigerant, read and follow the instructions and warnings in this manual, and wear protective equipment such as goggles and gloves.

Unpack the Accessory Kit

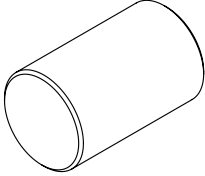
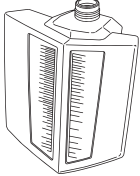
Unpack the accessory kit from the box, and remove the plastic packaging.

Calibration Check Weight 533 g (1.18 lb) 	Oil Drain Bottle 
Pouch containing the user manual, safety data sheets, and a service center list.	Tank Adapter 

Install the Oil Drain Bottle

1. Locate the oil drain coupler on the front of the machine (see Figure 1).
2. Lubricate the O-ring inside the coupler.
3. Insert the oil drain bottle into the coupler, pushing straight upward. (Do not use a twisting or rocking motion.)

Power Up the Machine

1. Unwind the power cord, and plug it into a correct voltage, grounded outlet.
2. Position the machine so the plug and the power switch are of easy access for the operator. Verify the fan vents on the rear of the machine are not obstructed.
3. Lock the front wheels.
4. Toggle the power switch on the control panel to turn the machine ON.

The machine launches into the initial Setup mode.

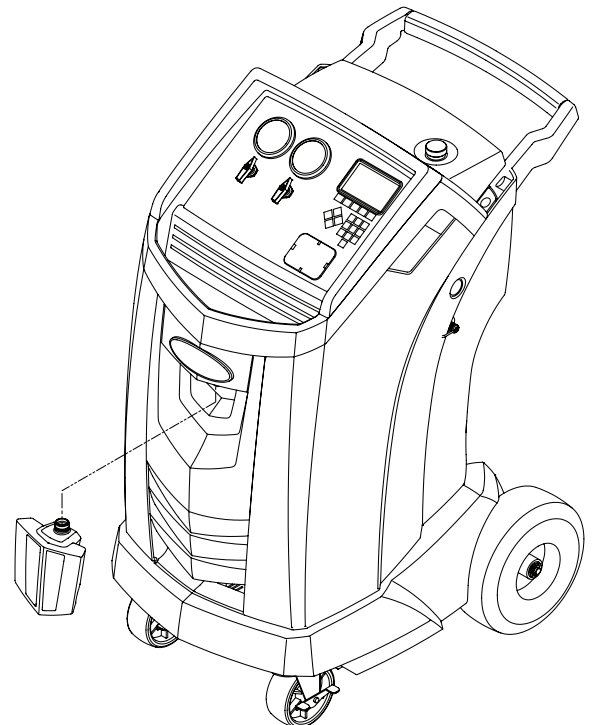

Figure 1

Initial Setup

Select Language

The operator selects the language for the screen prompt displays. English is the default language.

1. Use the **UP** or **DOWN** arrow key to toggle through the available languages one line at a time.
2. Select ✓ to set the selected language.

Note: To update an existing language or to add a new language, refer to Load Language in the Maintenance section of this manual.

Select Units

The operator sets the display for units of measure. Metric is the default.

3. Use the **ARROW UP** or **ARROW DOWN** key to toggle Imperial or Metric units.
4. Select ✓ to choose the displayed unit of measure.

Set Date and Time

Use the arrow keys to move the cursor. Use the keypad to modify the information displayed.

5. Use the **ARROW UP** and **ARROW DOWN** keys to select which item to change: day, month, year, or time. Select **I/O** to toggle between AM and PM.
6. Use the multi-tap interface on the numeric keypad to modify the information.
7. Select ✓ to save.

Edit Print Header

This machine has the capability to print recovery, vacuum, and charge information if a printer is installed (sold separately). The information loaded into Edit Print Header will appear on each printout.

1. Enter text by using the arrows and the multi-tap interface on the numeric keypad:
 - **ARROW LEFT** and  key act as backspace key.
 - **ARROW RIGHT** moves the cursor to the right.
 - **0 (ZERO)** acts as a spacebar when pressed twice.
 - **ARROW UP** and **DOWN** navigate between the rows.
2. Select ✓ to save/exit the function; select ✕ to return to the previous header without saving data.

Service Vacuum

At this point the machine clears its internal plumbing before proceeding with setup.

1. Check the vacuum pump oil level sight glass and verify the oil level is at the center of the sight glass.
2. When prompted, connect the service hoses from the machine to their storage ports as shown in Figure 2. Select ►► to continue.
3. The machine enters a 5-minute vacuum and will automatically enter the next set-up process when complete.

Tank Fill

This procedure transfers refrigerant from a source tank to the internal storage vessel (ISV) in the machine. The maximum capacity of the ISV is 10 kg (22 lb). Use arrow keys to move the cursor; use the keypad to enter a value.

1. The machine displays fields for desired tank fill amount, charge capacity, and the amount of recoverable refrigerant (recover capacity) within the internal storage vessel. Enter the desired tank fill amount.

Note: Add at least 3.6 kg of refrigerant to ensure enough is available for charging.

2. Install the tank adapter (included) to the source tank.
3. Connect the low-side service hose coupler to the tank adapter.
4. Open the source tank valve, low-side coupler valve, and low-side panel valve.
5. Position the source tank in such a way that liquid refrigerant is supplied to the connection.
6. Select ✓ to start the tank fill process. The machine begins filling the internal storage vessel (ISV). Add at least 3.6 kg of refrigerant to ensure enough is available for charging. This process takes 15–20 minutes.
7. The machine stops when the designated amount of refrigerant has been transferred to the ISV or when the source tank is empty. Follow the messages on the display.
8. Close the source tank valve.
9. Select ✕ to complete Initial Setup.

The machine is ready for operation.



WARNING: To prevent personal injury while working with refrigerant, read and follow the instructions and warnings in this manual, and wear protective equipment such as goggles and gloves.

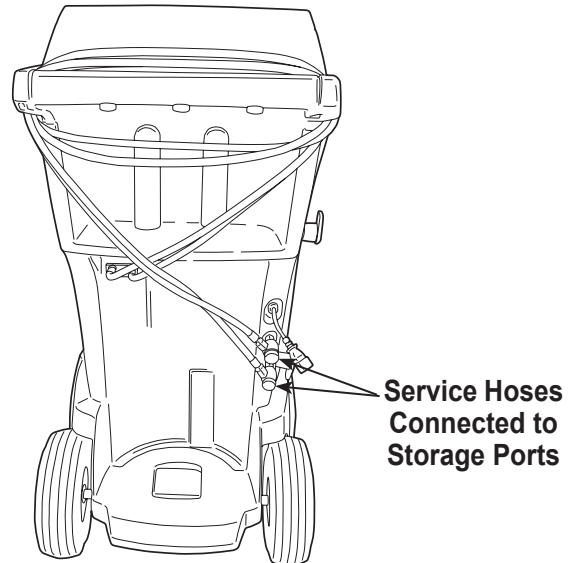

Figure 2

Notes:

- There is no need to calibrate the scale; it is calibrated at the factory.
- After the tank fill process is complete, the display does not show the same amount as the programmed fill level.
- The display shows the amount of refrigerant that is available for charging, which is approximately 0.67 kg (1.4 lb) less than the total amount of refrigerant in the tank.
- For optimum performance during tank-fill operation, verify proper orientation of source tank. Some tanks may need to be inverted for liquid supply.

Charge Capacity: The amount of refrigerant in the ISV that can be charged into a vehicle A/C system.

Recover Capacity: The amount of additional refrigerant that could be recovered into the ISV.

Initial Setup

Unit Activation

Failure to register and activate the machine within 30 days of initial startup will cause the machine to lock out and no longer function.

1. Select Unit Activation from the Setup Menu. The machine displays

XX Days Left on Trial
Period to activate unit.
Activate Now?

2. Select to start the activation process. The machine displays

Product Activation

Personal product code:
XXXXXXXXXXXX

Enter code:
XXXXXXXXXXXX



3. Open a web browser on a personal computer and enter register.servicesolutionsportal
4. Enter the user name and password, and log in to the website.
Note: If a first-time user, select REGISTER to create a user name and password.
5. On the personal computer, enter the Personal Product Code of the machine into the Product Activation key box on the website to receive an activation code.
6. On the machine, enter the activation code into the correct field. Note: Enter the code exactly as received. Capitalization is required.
7. Record the activation code on a piece of paper and file it in a secure place. Select .
8. The machine displays

Activation successful.

Select **▶▶**. The machine has been activated.



Recover Refrigerant from a Vehicle



1. Empty the oil drain bottle before starting a recovery. Remove the oil drain bottle from the machine by pulling the bottle straight down—do not use a twisting or rocking motion. Reinstall the oil drain bottle. See Figure 3.
2. Select **RECOVER**  from the **MAIN MENU**.
3. Connect the high-side (red) and low-side (blue) service hoses to the vehicle A/C system.
4. Open the coupler valves on the hoses by turning the collars clockwise.
5. Open the high-side and low-side valves on the control panel.
6. Select  to continue.

The machine begins the recovery process. A clicking noise indicates the solenoid is opening and closing — this is normal.

The machine runs a self-clearing cycle to clear any internal refrigerant from its internal plumbing.

System recovery begins and includes a timed vacuum, deep recovery process.

After recovery, the machine will perform an oil drain, which may require up to 90 seconds to complete.

7. After the oil drain is complete, a summary is displayed showing the total amount of refrigerant recovered. The user is prompted to “Check Oil Drain Bottle” to note amount of oil drained. Recovery information can be printed by selecting  on machines equipped with a printer.
8. Select  to return to the Main Menu.

Note: The displayed recovered weight can vary depending on ambient conditions and should not be used as an indicator of scale accuracy.

Note: The amount of oil that was removed from the A/C system is the amount of new oil that should be charged into the A/C system after evacuation is complete.

- Only new lubricant, as specified by the system manufacturer, shall be installed in the MAC System. Lubricant removed from the system and/or the equipment shall be disposed of in accordance with the applicable federal, state and local procedures and regulations.



WARNING: To prevent personal injury while working with refrigerant, read and follow the instructions and warnings in this manual, and wear protective equipment such as goggles and gloves.

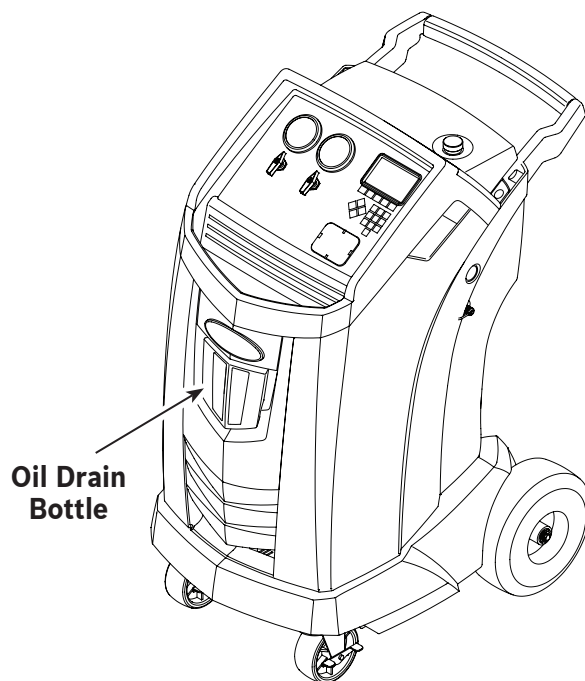





Figure 3

Operating Instructions



Evacuate the Vehicle A/C System

1. Select **VACUUM**  from the **MAIN MENU**.
2. Select Vacuum Leak Check, if desired, to automatically perform a 5-minute pressure rise leak check after the vacuum.
3. Select  to accept the 10-minute default evacuation time, or enter a desired vacuum time using the number keys.
4. Connect the service hoses to the vehicle's service ports.
5. Open the service hose coupler valves by turning the collars clockwise.
6. Open both panel valves.
7. Select  to begin the vacuum process.

Note: The vacuum process will halt if pressure rises above 1.1 bar (16 psi). Recover refrigerant before proceeding.

The machine pulls a vacuum on the A/C system for the programmed amount of time.

Vacuum information can be printed by selecting  on machines equipped with a printer.

8. Select  to return to the Main Menu.

IMPORTANT: The machine pulls a vacuum on the vehicle's A/C system to remove air and boil off moisture. Evacuate the system for at least 10 minutes to ensure adequate moisture and contaminant removal, unless otherwise specified by the vehicle manufacturer.



WARNING: To prevent personal injury while working with refrigerant, read and follow the instructions and warnings in this manual, and wear protective equipment such as goggles and gloves.



Recharge the Vehicle A/C System

1. Connect both service hoses to the vehicle's service ports.
2. Select **CHARGE**  from the **MAIN MENU**.

The display shows

Charge: XX.XXX kg
Charge Path: HIGH
Min Charge quantity 10g

3. Use the arrow keys and the numeric keypad to enter the desired charge amount. Select **kg lbs oz** to change units.
4. Using the arrow keys, maneuver to the charge path selection. High Side is default. Select **HSL** to toggle between high, low, and both side charge paths. The current selection is indicated on the display.
5. Select **▶▶** to continue.
6. Follow on-screen prompts to adjust panel valve positions based on the charge path specified.

Note: Oil may be injected at this time using Robinair injector 18480 or 18490 (sold separately).

7. Select **▶▶** to start the charge process. Moving or bumping the machine at this point may result in an inaccurate charge. When the charge cycle approaches the desired weight value, the machine slows down. It will charge, settle, charge again, settle, etc.
8. Follow on-screen prompts to perform hose equalization.
Note: Hose equalization requires the user to start the vehicle.
9. The user will be prompted to close the coupler valves and disconnect the hoses from the vehicle. Select **▶▶** to recover any remaining refrigerant from the hoses.
10. When the **CHARGE COMPLETE** screen appears, it includes a summary of charge results. The user may select  to print the summary, if a printer is installed. Select **▶▶** to return to the main menu.

The vehicle A/C system is now ready for use.



WARNING: To prevent personal injury while working with refrigerant, read and follow the instructions and warnings in this manual, and wear protective equipment such as goggles and gloves.

Note: The charging process differs from vehicle to vehicle. Charge function for vehicles equipped with a single service fitting should be carried out manually. Refer to the vehicle service manual for specific instructions.

CAUTION: If the low-side (blue) or high-side (red) coupler valve is left open during the hose clearing process, the system will pull refrigerant back out of the vehicle.

Operating Instructions





Automatic Function

The **AUTOMATIC** function allows a user to perform an automatic recovery, vacuum, leak test, and/or charge sequence. A total automatic sequence may take up to an hour to complete.

1. Connect high-side (red) and low-side (blue) service hoses to the A/C system.
2. Open the service hose coupler valves by turning the collars clockwise.
3. Select **AUTOMATIC**  from the **MAIN MENU**. The display shows

Vacuum Time: XX:XX
Charge: XX.XXX kg
Charge Path: High

4. Use the numeric keypad to enter the desired length of vacuum.
5. Use the arrow keys and the numeric keypad to enter the desired charge amount. Select **kg|lbs|oz** to change units.
6. Using the arrow keys, maneuver to the “charge path selection.” High Side is default. Select **HSLS** to toggle between high, low, and both side charge paths. The text on the display will change to the current selection.
7. Select **▶▶** to continue.
8. Follow on-screen prompts to adjust valve positions.
9. Select **▶▶** to begin the **AUTOMATIC** cycle. The unit will now proceed through all applicable functions: **RECOVER**, **VACUUM**, and **CHARGE**.

If the machine detects low pressure, follow on-screen prompts and select  to continue automatic cycle with recovery,  to perform vacuum, or  to cancel.
10. Before recharging the system, the machine’s display will illuminate yellow, indicating user input is required. Follow on-screen prompts to adjust panel valve positions based on the charge path specified.

Note: Oil may be injected at this time using a manual oil injector.



WARNING: To prevent personal injury while working with refrigerant, read and follow the instructions and warnings in this manual, and wear protective equipment such as goggles and gloves.

11. Select **▶▶** to start the charge process. Moving or bumping the machine at this point may result in an inaccurate charge. When the charge cycle approaches the desired weight value, the machine slows down. It will charge, settle, charge again, settle, etc.
12. Follow on-screen prompts to perform hose equalization.
Note: Hose equalization requires the user to start the vehicle.
13. The user will be prompted to close the coupler valves and disconnect the hoses from the vehicle. Select **▶▶** to recover any remaining refrigerant from the hoses.
14. When the **AUTOMATIC COMPLETE** screen appears, it includes a summary of results. The user may select  to print the summary, if a printer is installed. Select **▶▶** to return to the Main Menu.

The vehicle A/C system is now ready to use.

*Note: The **CHARGE** function for vehicles equipped with a single-service fitting should be carried out manually according to procedures in the vehicle manufacturer’s service manual.*

IMPORTANT: The machine pulls a vacuum on the vehicle’s A/C system to remove air and boil off moisture. Evacuate the system for at least 10 minutes to ensure adequate moisture and contaminant removal, unless otherwise specified by the vehicle manufacturer.

Maintenance Schedule

Maintenance Task	Recommended Interval
Change filter	After 68 kg (150 lb) of refrigerant has been filtered. Refer to Filter Maintenance in the Maintenance section of this manual.
Change vacuum pump oil	When the filter is replaced. Refer to Change Vacuum Pump Oil in the Maintenance section of this manual.
Check casters and wheels for ease of operation	Monthly.
Check internal scale calibration	Monthly. Refer to Calibration Check in the Maintenance section of this manual.
Check machine for leaks	Monthly. Check hoses and connections for leakage. Disconnect power, remove the shroud, and use an electronic leak detector to check fittings.
Clean airflow outlet panel (see Figure 4)	Monthly. Use a clean cloth.
Clean cabinet and control panel	Monthly. Use a clean cloth.
Inspect power cord and hoses for cuts and abrasions	Daily.
Lubricate wheel bearings and inspect brake components	Monthly.
Pressure Test	Every 10 years. Performed by an authorized Robinair service center.

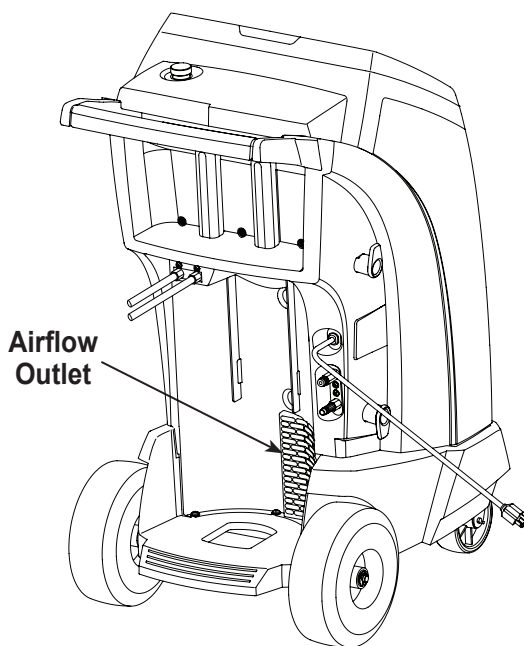

Figure 4



WARNING: To prevent personal injury only qualified personnel may perform inspections and repairs to this machine. Read and follow instructions and warnings in this manual, and wear protective equipment such as goggles and gloves.

Maintenance

Load Language

Use the following instructions to add or update a language from an SD card.

1. Choose **SELECT LANGUAGE** from the **SETUP MENU**.
2. Use the arrow keys to scroll to **LOAD NEW**. Select **✓**.
3. Insert the SD card containing the language data. See Figure 5.

Note: Access to SD card slot may require removal of shroud. See Figure 7 on page 23.

4. Follow the prompts to select the language to load or update. If loading a new language, it will be necessary to select which language to replace.

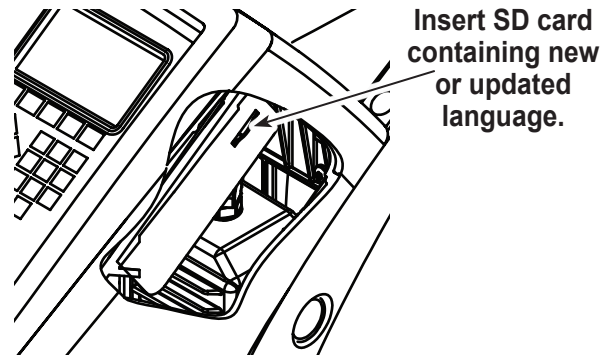



Figure 5

Tank Fill

This menu item is used to transfer refrigerant from a source tank to the ISV.

The maximum capacity of the internal storage vessel (ISV) is 10 kg. Use the arrow keys to move the cursor; use the keypad to enter a value.

Note: Add at least 3.6 kg of refrigerant to ensure sufficient refrigerant is available for charging.

1. The machine displays fields for desired tank fill amount, charge capacity, and the amount of recoverable refrigerant (recover capacity) within the internal storage vessel. Enter the desired tank fill amount.
2. Install the tank adapter (included) to the source tank.
3. Connect the low-side service hose coupler to the tank adapter.
4. Open the source tank valve, low-side coupler valve, and low-side panel valve.
5. Position the source tank in such a way that liquid refrigerant is supplied to the connection.
6. Select  to start the tank fill process. The machine begins filling the internal storage vessel (ISV). Add at least 3.6 kg of refrigerant to ensure enough is available for charging. This process takes 15–20 minutes.
7. The machine stops when the designated amount of refrigerant has been transferred to the ISV or when the source tank is empty. Follow the messages on the display.
8. Close the source tank valve.
9. Select  to complete Initial Setup.

The machine is ready for operation.

Notes:

- *There is no need to calibrate the scale; it is calibrated at the factory.*
- *After the tank fill process is complete, the display does not show the same amount as the programmed fill level.*
- *The display shows the amount of refrigerant that is available for charging, which is approximately 0.67 kg (1.4 lb) less than the total amount of refrigerant in the tank.*
- *For optimum performance during tank-fill operation, verify proper orientation of source tank. Some tanks may need to be inverted for liquid supply.*



WARNING: To prevent personal injury while working with refrigerant, read and follow the instructions and warnings in this manual, and wear protective equipment such as goggles and gloves.

Charge Capacity: The amount of refrigerant in the ISV that can be charged into a vehicle A/C system.

Recover Capacity: The amount of additional refrigerant that could be recovered into the ISV.

Maintenance

Filter Maintenance

The filter is designed to trap acid and particulates, and to remove moisture from refrigerant. To meet the mandate for adequate moisture and contaminant removal, the filter must be replaced after 68 kg (150 lb) of refrigerant has been filtered.

The machine gives a warning when 57 kg (125 lb) of the filter capacity has been used; the machine locks down when the 68 kg (150 lb) filter capacity has been reached and will no longer function.

Check Remaining Filter Capacity

1. Select **FILTER MAINTENANCE** from the **SETUP MENU** or when the machine prompts. The machine displays

Remaining Filter Capacity: XXX.XO kg
Replace filter now?

The machine displays the amount of filter capacity remaining until the machine locks down.

2. Select ✓ to change the filter; select ✗ to resume using the machine.

⚠ WARNING: The components in the machine are under high pressure. To prevent personal injury, change the filter only when the machine prompts.



WARNING: To prevent personal injury while working with refrigerant, read and follow the instructions and warnings in this manual, and wear protective equipment such as goggles and gloves.

Replace the Filter

1. If ✓ was selected to change the filter, the machine prompts for the new filter code to be entered.

Enter new filter serial number

Use the keypad to enter the serial number that appears on the new filter, and select ✓ to continue.

Note: If "Invalid serial number" is displayed, the serial number has been incorrectly entered, or the filter has already been used in this machine.

2. The machine clears the existing filter and displays

Serial number accepted.

Turn power off and replace filter.

Turn off the machine. Remove the oil drain bottle. Remove the screws holding the shroud. See Figure 6.

3. Hang the shroud on the back of the machine as shown in Figure 7.
4. Remove the filter by turning it counterclockwise (as viewed from the bottom of the filter).
5. Look at the new filter. Verify both o-rings are lubricated and correctly located in the grooves.
6. Install the new filter by threading it clockwise into place. Verify the filter is positioned correctly as shown in Figure 7. Tighten the filter to 20 Nm.
7. Power the machine on. The Change Vacuum Pump Oil operation will begin, and the screen will display

Warming oil for drain XX:XX

See Change Vacuum Pump Oil for more information.

The machine will then begin the Leak Check operation. See Leak Check section for more information.

Caution: To prevent equipment damage, use only authentic Robinair No. 34724 filters in this machine. All performance tests and claims are based on using this specific filter.

Remove the screws holding the shroud.

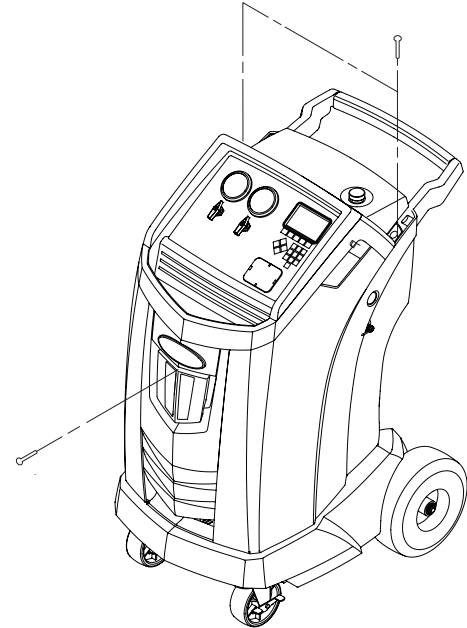

Figure 6

Hang Shroud Here

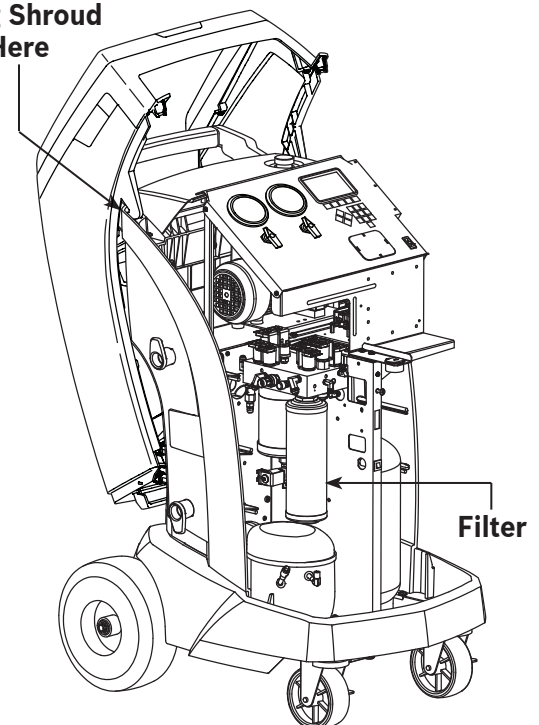

Figure 7

Maintenance

Calibration Check

This function is used to ensure the machine's internal scale is always calibrated. During this test, use only the calibration weight that is provided with the machine.

1. Refer to Figure 8, and verify the magnet on the bottom of the machine is clean.
2. Select **CALIBRATION CHECK** from the **SETUP MENU**.
The machine displays

Place calibration weight onto the magnet located on the bottom of the machine.

3. Attach the calibration weight to the magnet on the bottom of the machine. Select ✓ to continue.
4. The machine displays

Remove calibration weight from the magnet located on the bottom of the machine.

Remove the calibration weight from the magnet. Select ✓ to continue.

- If the display shows

Calibration check passed

the scale is in calibration. Select ►► to return to the Setup Menu.

- If the display shows

Calibration check failed. Retry?

the scale is out of calibration. To retry, select ↺. If calibration continues to fail, contact an authorized Robinair service center for assistance.

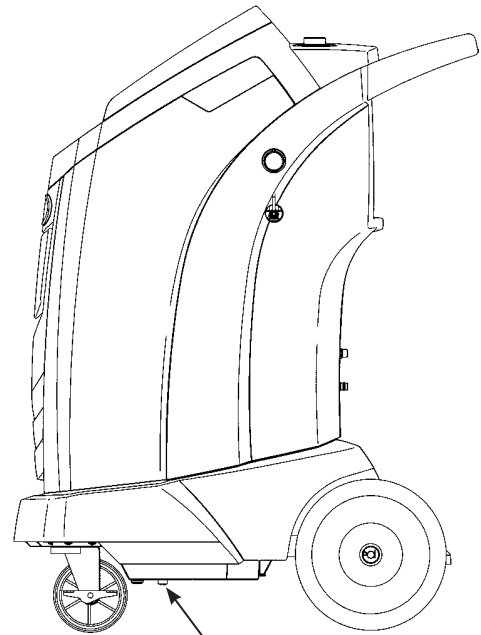

Magnet

Figure 8

Change Vacuum Pump Oil

1. Select **PUMP MAINTENANCE** from the **SETUP MENU** or when prompted. The display shows

Remaining oil life:
XXX:XX (hhh:mm)
Change oil now?

2. Select to change vacuum pump oil. If the machine displays

Warming oil for drain
XX:XX

allow the vacuum pump to run for two minutes to warm up the oil. If the oil is already warm, the display shows

Drain used oil from pump
and replace with 150 ml of new oil
Remove fill cap to speed draining of oil

3. **Slowly** open the oil fill cap to verify there is no pressure in the machine. Then carefully remove the cap. See Figure 9.
4. Remove the oil drain fitting cap and drain the oil into a suitable container for disposal. Replace the cap and close tightly. Select **▶▶** to continue.
5. The machine displays

Fill vacuum pump to the center
of the sight glass
Reinstall fill cap

Slowly add vacuum pump oil to the pump through the oil fill port until the oil reaches the center of the sight glass. Install the cap on the oil fill port and close tightly. Select **▶▶** to return to the **SETUP MENU**.

Notes:

- For proper oil level, ensure the machine is on a flat, level surface.
- Robinair vacuum pump oil is available in various sizes. See "Replacement Parts" section.

⚠ WARNING: To prevent personal injury, do NOT operate the machine at any other time without the oil fill port cap installed, because the vacuum pump is pressurized during normal operation.

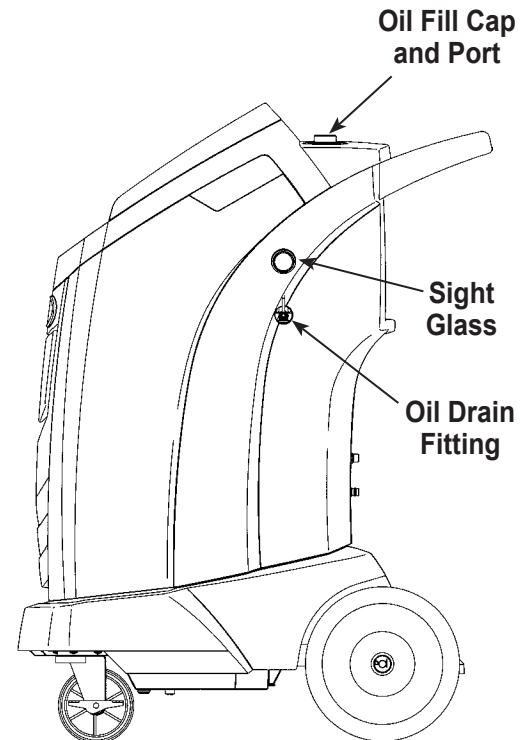

Figure 9

CAUTION: It is the responsibility of the user to monitor vacuum pump oil level and clarity. If contaminated oil is not removed from the vacuum pump and replaced, the vacuum pump will be permanently damaged.

Maintenance

Leak Check

A leak test may be performed on the machine at any time. During this test, components containing refrigerant are pressurized. An electronic leak detector is required.

Note: The leak check function is to check for leaks on the Robinair unit and its components only. This procedure is not for checking for leaks on the vehicle A/C system.

1. Select **LEAK CHECK** from the **SETUP MENU**. The machine displays

Connect service hoses to storage ports, open coupler valves, and open panel valves.

2. Connect the service hose couplers to the storage ports at the rear of the machine. Open the couplers by turning the collars clockwise. Turn panel valves to open position.
3. Remove and store shroud as shown in Figure 6 and Figure 7.
4. Select ✓ to start. The machine performs a self-recovery and displays

Recover in progress

The machine performs a 30-second vacuum test and displays

Vacuum leak check in progress

If the vacuum test fails, the machine will prompt to check for leaks.

Once the machine passes the vacuum test, a controlled pressure is applied. The machine displays

Use an electronic leak detector to search the unit for leaks.

5. Scan the machine's internal and external components with the leak detector, specifically high-risk areas such as hoses and fittings.
6. Select ✓ to continue. The machine performs a self-recovery to clear the refrigerant used for the leak test, and the process is complete.

CAUTION: If a leak is detected, contact an authorized Robinair service center for repair.



WARNING: To prevent personal injury while working with refrigerant, read and follow the instructions and warnings in this manual, and wear protective equipment such as goggles and gloves.

WARNING: To prevent personal injury should the machine require transport to a local Robinair service center, follow local government regulations regarding transportation of equipment containing R-134a.

Edit Print Header

To make changes to text that appears in this screen:

1. Select **EDIT PRINT HEADER** from the **SETUP MENU**.
2. The cursor is in the first field. Update the text by using the arrows and the multi-tap interface on the numeric keypad:
 - **ARROW LEFT** and **X** act as a backspace key.
 - **ARROW RIGHT** moves the cursor to the right.
 - **ZERO (0)** key acts as a spacebar.
 - **ARROW UP** and **DOWN** navigate between the rows.
3. Select **✓** to save the changes and return to the Setup Menu; select **X** to return to the previous header and exit to the Setup Menu.

Replace Printer Paper

To install a new paper roll in the printer:

1. Remove the cover on the printer by pulling out on the tab as shown in Figure 10.
2. Remove the paper core.
3. Install the new roll of paper with the end of the paper at the top of the roll.
4. Assemble the cover onto the printer with the leading edge of the paper over the roller.

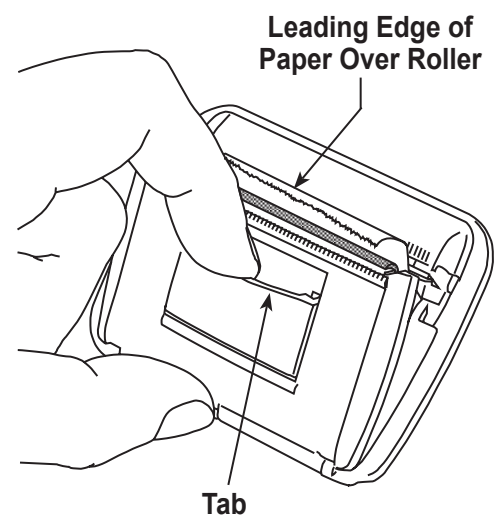

Figure 10

Maintenance

Install a Printer

1. Turn **OFF** the machine and disconnect it from its power source.
 2. Remove the oil drain bottle.
 3. Remove the screws holding the shroud. See Figure 6.
 4. Hang the shroud on the back of the machine as shown in Figure 7.
 5. Remove the two screws on the top corners of the control panel, allowing the control panel to swivel forward.
 6. Remove the cap from the printer location cutout by pressing on the cap's tabs from the back of the control panel and pushing the cap out of the panel.
 7. Remove the two locking arms from the printer by inserting the face of a flathead screwdriver under each tab near the back of its locking arm. Pry the tab outward while sliding the entire arm away from the printer.
 8. Place the printer into the cut-out area on the control panel. Press the face of the printer flush to the panel, oriented with the paper coming out at the top of the printer as shown in Figure 10.
 9. Replace the printer locking arms from within the inside of the control panel. Push them forward until they come into firm contact with the inside face of the control panel.
 10. Using the harness included with the printer, connect to the control board as shown in Figure 11. The wires are marked with their respective connector labels.
 11. Attach the two free connectors to the appropriate connectors on the back of the printer.
 12. Swivel the control panel back into place and fasten it using the two screws removed in Step 5.
 13. Assemble the shroud back onto the machine and install the screws removed in Step 3.
 14. Reinstall the oil drain bottle.
- The printer is now ready for use.

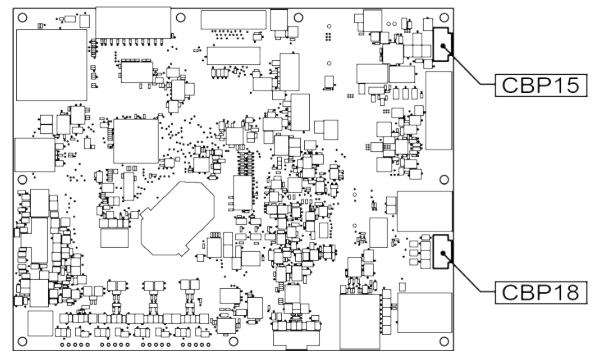



Figure 11

Replacement Parts

Component	Replacement Part No.
Calibration Weight	16214
Filter	34724
Oil Drain Bottle	19100
Printer	30038
Printer Paper (3 rolls)	34214
LP Service Coupler	18190A
HP Service Coupler	18191A
Service Coupler Set (high-side [red] and low-side [blue] couplers)	18192
Hose Set without Couplers (high-side [red] and low-side [blue])	71789
Service Hose without Coupler (low-side, blue)	70020
Service Hose without Coupler (high-side, red)	70021
Tank Fill Adapter	16301
Oil Injector (PAG)	18480
Oil Injector (POE)	18490
Vacuum Pump Oil (pint)	13119
Vacuum Pump Oil (quart)	13203
Vacuum Pump Oil (gallon)	13204
Vinyl Dust Cover (optional)	17499

 **WARNING:** To prevent personal injury, use only those repair parts called out in this parts list. Items found in this parts list have been carefully tested and selected by Robinair.

Glossary

A/C System : The vehicle air conditioning system being serviced.

Evacuation : Moisture and other non-condensables are removed from an A/C system by a vacuum pump.



Internal Storage Vessel (ISV) : The refillable refrigerant storage tank designed specifically for this machine; 10 kg (22 lb) capacity.

Machine : Model No. 34288NI.







Recovery / Recycling : Refrigerant is recovered from an A/C system, filtered, and stored in the ISV.

Refrigerant : R-134a.

Troubleshooting

Display	Cause	Solution
CALIBRATION CHECK FAILED	Internal scale is out of calibration.	Select  to retry calibration check. If calibration continues to fail, exit current test and contact a Robinair authorized service center for repair.
CHARGE STALLED!	Refrigerant is stalled in the ISV or the machine.	Verify connections are secure and valves are in correct position.
DATABASE NOT AVAILABLE	Machine is not shipped with database installed.	Contact a Robinair authorized service center for more information.
EXCESS TANK WEIGHT	Overfill safety circuit tripped. Machine is locked out because of too much refrigerant in ISV.	Contact a Robinair authorized service center for more information.
FILTER CAPACITY EXHAUSTED, FILTER MUST BE REPLACED FILTER WEIGHT XXX.XYY REPLACE FILTER NOW?	68 kg (150 lb) or more refrigerant has been recovered since last filter change.	Refer to Filter Maintenance section of this manual for instructions to change filter.
FILTER SERIAL NUMBER HAS ALREADY BEEN USED. RE-ENTER OR EXIT	Filter serial number entered into the machine is not correct.	Filter has already been used on this machine. Obtain new Robinair filter No. 34724.
HIGH TANK PRESSURE	Machine is locked out because pressure in ISV is too high, possibly because of excessively high tank temperature.	Allow machine to cool before performing additional A/C service. If problem continues, contact a Robinair authorized service center for more information.
INLET PRESSURE IS TOO HIGH FOR VACUUM	Before the machine begins evacuating the A/C system, it checks for pressure in the system that could damage the vacuum pump. In this case, system pressure is above 0.62 bar gauge (9 psi).	Select  . Refer to Recover section of this manual to recover refrigerant before proceeding.
INSUFFICIENT REFRIGERANT AVAILABLE FOR CHARGE SELECTED: XX.XXYY AVAILABLE: XX.XXYY	After a desired weight is entered, if the charge process will leave less than 0.67 kg (1.4 lb) of refrigerant in ISV, the charge function will not start.	Refer to Tank Fill in the Maintenance section of this manual.

Troubleshooting

Display	Cause	Solution
INVALID CODE	Activation code entered into the machine is not correct.	Verify activation code is entered exactly as received. Capitalization is required.
INVALID SERIAL NUMBER!	Filter serial number entered into the machine is not correct.	Verify serial number entered matches serial number on filter. Verify filter has not been used on machine previously.
NO PRESSURE ON INLETS CHECK CONNECTIONS RECOVER ANYWAY?	System pressure is below 0.62 bar gauge (9 psi).	Verify high-side (red) and low-side (blue) hoses are connected and panel valves and coupler valves open. Select   to RECOVER; select   to bypass recover and proceed to VACUUM.
OIL DRAIN HALTED	The machine's internal conditions have caused the oil drain process to take an excessive amount of time.	Select  to retry; select  to exit. If retry does not resolve the issue and ISV contains at least 0.67 kg (1.4 lb) of refrigerant, contact an authorized Robinair service center.
OUT OF RANGE ACCUMULATOR PRESSURE	Accumulator pressure transducer is reading pressure outside of normal operating range.	Exit current test and contact a Robinair authorized service center for more information.
OUT OF RANGE ISV PRESSURE	Internal storage vessel pressure transducer is reading pressure outside of normal operating range.	Exit current test and contact a Robinair authorized service center for more information.
OUT OF RANGE ISV TEMPERATURE	Internal storage vessel temperature sensor is reading temperature outside of normal operating range.	Exit current test and contact a Robinair authorized service center for more information.
POWER BOARD COMMUNICATION FAILED	Communication error between control boards within the machine.	Cycle power. If problem continues, contact an authorized Robinair service center for more information.
SOURCE TANK IS EMPTY	Refrigerant cannot be transferred to the ISV.	If all connections and valve positions have been verified, exit current test and replace the source tank.

Troubleshooting

Display	Cause	Solution
TANK FULL. REMOVE REFRIGERANT BEFORE CONTINUING	ISV is too full to recover additional refrigerant.	<i>Perform a charge process to remove refrigerant from ISV before any further recovery attempts.</i>
TRIAL PERIOD EXPIRED UNIT ACTIVATION REQUIRED TO CONTINUE USE	Failure to register and activate the machine within 30 days of initial startup will cause the machine to lock out and no longer function.	<i>Select ✓ and refer to Unit Activation section in this manual to register the machine.</i>

Storage and Transportation of Equipment

Storage

Never leave the machine live if an immediate use is not scheduled.

1. Disconnect the machine from its power supply.
2. Loop the service hoses around the handle twice and attach them to the storage ports. See Figure 12.
3. Store the machine in a dry, stable area, away from flames and hot surfaces. The temperature of the storage area should range between -18°C and 60°C (0°F and 140°F).
4. Lock the front wheels.

Transportation of Equipment

! **WARNING:** To prevent personal injury, should the machine require transport to a Robinair service center, follow local government regulations regarding transportation of equipment containing R-134a.

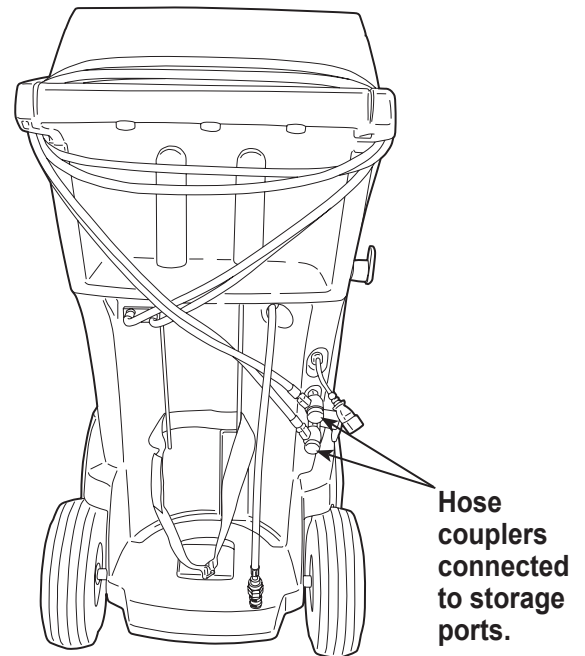

Figure 12

Disposal of Equipment



At the end of its useful life, dispose of the R-134a machine according to current government regulations.

- Public administration and producers of electrical / electronic equipment (EEE) are involved in facilitating the processes of the re-use and recovery of waste electrical / electronic equipment through the organization of collection activities and the use of appropriate planning arrangements.
- Do not dispose of this equipment as miscellaneous solid municipal waste. Arrange to have it collected separately. Unauthorized disposal of waste electrical / electronic equipment is punishable by law with appropriate penalties.
- The reuse and correct recycling of electrical / electronic equipment (EEE) is required for the protection of the environment and the well-being of humans.

Disposal of Recycled Materials

It is the responsibility of the user to determine if a material is a hazardous waste at the time of disposal. The user must ensure compliance with all applicable laws and regulations.

1. Deliver the refrigerant recovered from A/C systems to gas suppliers for recycling or disposal.
2. Deliver the lubricants extracted from A/C systems to used oil collection centers.
3. Review the laws in your jurisdiction to determine correct disposal procedures for pump oil.

Disposal of the Machine

1. Detach and vent the gas from the machine circuit. Completely discharge the refrigerant tank in compliance with current government regulations.
2. Deliver the machine to an appropriate disposal center.

Disposal of Batteries



At the end of their useful life, dispose of batteries according to current government regulations. Batteries must be recycled or disposed of correctly. Do not throw away batteries as part of normal refuse disposal.



WARNING: To prevent personal injury, do not throw batteries into open flame.
