

Installation Instructions

15144/15547/15548 Replacement Vacuum Pump (less motor)



WARNING



Unplug the unit before beginning service work. Incorrect use or connections can cause electrical shock.

Follow these procedures to replace the vacuum pump (less motor assembly) in your 15120A, 15121A, 15401, or 15601 VacuMaster® vacuum pump. The numbers shown in parentheses correspond to the callouts in the drawings.

1. Drain the oil from the vacuum pump following the instructions in your pump's operating manual.
2. Remove the gas ballast valve (1). On 15120A/15121A pumps **only**, remove the exhaust filter from the oil fill port (10).
3. Loosen the handle bolt (2) from the housing (3), but do not remove it from the handle (4).
4. Turn the pump on its nose on the edge of a table, and loosen the four clamp bolts (5) from the housing (3), but do not remove them from the motor. Lift the motor (6) off the housing and set aside.
5. Remove the base (7) and discard the old pump (less motor). Locate the old rubber spider (8) and discard it.
6. Remove the gas ballast valve (1) from the new pump (less motor); set the assembly on its nose.
7. Place the new spider (8) into the coupler half that is attached to the new pump (less motor).
8. Remove the coupler half (9) that is attached to the motor shaft and discard it. Assemble the appropriate new coupler half to the motor shaft, locating

it in approximately the same position as the old coupler.

9. Before attempting to reassemble the motor to the pump, align the coupler halves so that they seat together.
10. Assemble the motor to the pump, taking care not to damage the rubber spider (8) as the two coupler halves (9) mate.
11. Partially thread the handle bolt (2) into the housing (3), but do not tighten.
12. Fully tighten the four clamp bolts (5). Do not cross thread!
13. Finish tightening the handle bolt (2). Do not over-tighten.
14. Adjust the coupler halves (9) if necessary, so they are separated by a gap of 1/16 to 1/8 inches.
15. Reassemble the base (7), and set the pump upright.
16. Insert the gas ballast valve (1) back into the housing. Do not cross thread!
17. On 15120A/15121A pumps **only**, remove and discard the red plug in the oil fill port (10).
18. Pour fresh oil into the pump reservoir, following directions in your pump's operating manual.
19. On 15120A/15121A pumps **only**, replace the exhaust filter in the oil fill port (10). Hand tighten the filter. If a new filter is required, order replacement part no. 15147.

Because of ongoing product improvements, we reserve the right to change design, specifications, and materials without notice.

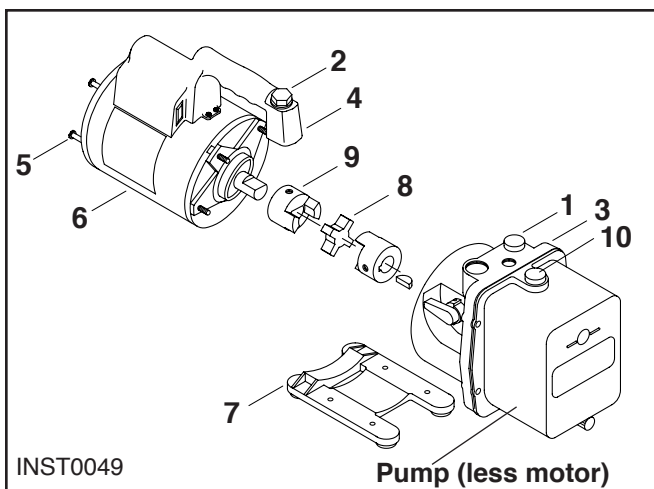

ROBINAIR

Discover other automotive A/C tools and equipment on our website.