

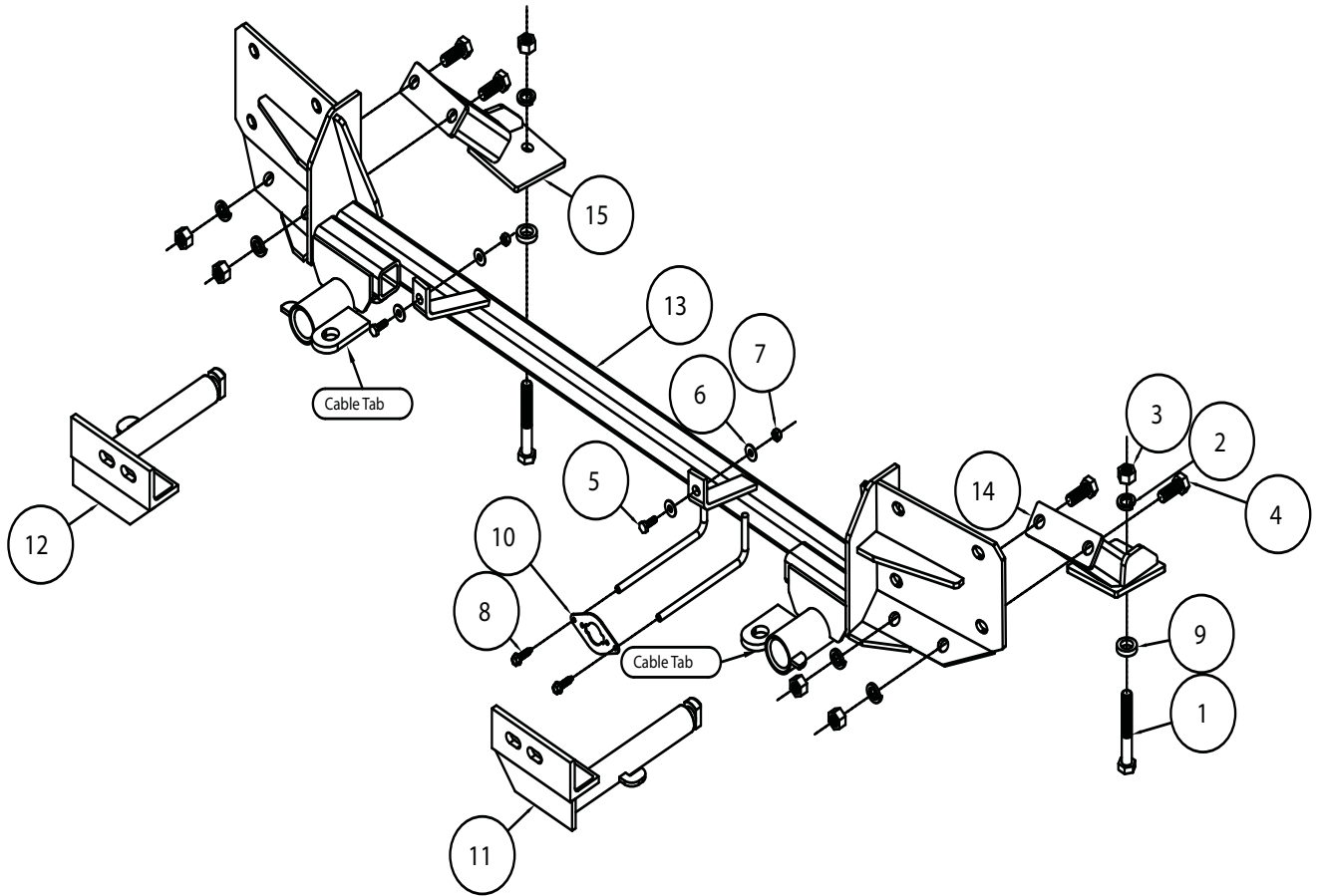

# MOUNTING BRACKET KIT KIT# 524429-1

## INSTALLATION INSTRUCTIONS



ITEM	QTY	NAME	MATERIAL
1	2	1/2" x 3 1/2" BOLTS	350103-00
2	6	1/2" LOCKWASHER	350309-00
3	6	1/2" HEX NUTS	350258-00
4	4	1/2" x 1 1/4" BLOT	350094-00
5	2	1/4" x 1" BOLTS	350005-00
6	4	1/4" WASHER	350300-00
7	2	1/4" NYLOCK NUTS	350251-00
8	2	#10 x 3/4" SELF DRILLING SCREW	350247-35
9	2	1" O.D. x 0.188 x 1/4" SPACER	A-001022
10	1	WIRE PLUG PLATE	A-003801
11	1	DRIVER SIDE ARM	C-002516
12	1	PASSENGER SIDE ARM	C-002517
13	1	MAIN RECEIVER	C-002518
14	1	DRIVER SIDE BRACE	C-002519
15	1	PASSENGER SIDE BRACE	C-002520



# MOUNTING BRACKET KIT INSTALLATION INSTRUCTIONS

**KIT# 524429-1**

This is one of our EZ2 series brackets, which allows the visible front portion of the bracket to be easily removed from the front of the vehicle (Fig.A and Fig.B). The bracket consists of a main receiver brace, two removable front braces, and a hardware pack.

The main receiver brace mounts to the sub-frame and support braces. The removable front braces install in the main receiver brace.

Before starting the installation, lay out the kit components in order, as they will be used. This will give you a visual idea of how the components work, and will also confirm that everything is present and accounted for.



Fig.A



Fig.B

**IMPORTANT:** All brackets *must* be assembled with all the bolts left loose for final adjustment and positioning (before tightening) unless otherwise instructed. All bolts *must* be torqued for proper strength. If more than one bolt is used per fastening point, the diagram may only show one.

- Use flat washers over all slotted holes
- Use lock washers on all fasteners

ROADMASTER Limited Warranty, including One-Year Conditional Warranty Text and Product Registration Card, in Carton.

## WARNING

Failure to follow these instructions can result in property damage, personal injury or even death.

- Installation of most mounting brackets requires moderate mechanical aptitude and skills. We strongly recommend professional installation by an experienced installer.
- The installer must read the instructions and use all bolts and parts supplied. Failure to do so could result in loss of the towed vehicle.
- Use Loctite® Red on all bolts used for mounting this bracket.
- Every 3,000 miles, the owner must inspect the fasteners for proper torque, according to the bolt torque requirements chart on the last page of these instructions. The owner must also inspect all mounts and brackets for cracks or other signs of fatigue every 3,000 miles. Failure to do so could result in loss of the towed vehicle.
- The owner must check the vehicle manufacturer's instructions for the proper procedure(s) to prepare the vehicle for towing. Some vehicles must be equipped with a transmission lube pump, an axle disconnect, driveline disconnect or free-wheeling hubs before they can be towed. Failure to properly equip the vehicle will cause severe damage to the transmission.
- If running changes were made by the vehicle manufacturer after this bracket was designed, some bolts or other fasteners in the hardware pack may no longer be the correct size. It is the installer's responsibility to verify that the bracket is securely fastened to the vehicle and fitted with the correct hardware to account for these changes. Failure to securely fasten the bracket could result in loss of the towed vehicle.
- If the towed vehicle has been in an accident, it must be properly repaired before attaching the bracket. Do not install the bracket if any structural frame damage is found. Failure to repair the damage could result in the loss of the towed vehicle.
- Roadmaster manufactures many styles of brackets. If your bracket has removable arms, they must be removed before driving the vehicle, unless the arms can be pinned or padlocked in place. If not secured, the arms could vibrate out, resulting in non-warranty damage or personal injury.
- Some motorhome chassis have such a tight turning radius that you can damage your motorhome, towed vehicle, tow bar or bracket while turning sharply. Before getting on the road, test your turning radius in an empty parking lot. Turning too sharply could result in non-warranty damage to towing system, motorhome and/or towed vehicle.
- Do not back up with the towed vehicle attached or non-warranty damage will occur to your towing system, motorhome and/or towed vehicle.
- The safety cables must connect the towing vehicle to the towed vehicle frame to frame, with the cables crossed, with enough slack for sharp turns. Refer to the cable instructions for proper routing. Failure to leave enough slack in the safety cables, or failure to connect the safety cables frame to frame, will result in the loss of the towed vehicle.
- This bracket is designed for use with ROADMASTER tow bars and ROADMASTER adaptors only. Using this bracket with other brands, without an approved ROADMASTER adaptor, may result in non-warranty damage or injury.
- Do not use this document for custom fabrication, as it may not show all parts or structural components. Custom fabrication or an attempt to copy this bracket design could result in loss of the towed vehicle.
- Upon final installation, the installer must inspect the bracket to ensure adequate clearance, particularly around hoses, air conditioner lines, radiators, etc., or non-warranty damage to the towed vehicle will result.
- This bracket is only warranted for the original installation. Installing a used bracket on another vehicle is not recommended and will void the warranty.





# MOUNTING BRACKET KIT INSTALLATION INSTRUCTIONS

**KIT# 524429-1**



1. **Important:** please use all supplied bolts and parts and read all instructions carefully before beginning this installation. The majority of questions you may have can be answered within the text, and proper installation will ensure safe and secure travel. Now, begin the installation. Remove four 10mm (head) bolts and two plastic fasteners attaching the radiator cover to the core support (Fig.C).

2. On each side, remove three 5.5mm screws and one plastic fastener attaching the fender wall to the fender (Fig.D).



3. Remove five plastic fasteners attaching the splash shield to the subframe (Fig.E) and an 8mm screw on each side attaching the fender liner to the splash shield (Fig.F).

4. Pull out and forward on the corners of the fascia to remove it from the locking strip (Fig.G). Disconnect the fog lights, if the vehicle is so equipped.







# MOUNTING BRACKET KIT INSTALLATION INSTRUCTIONS

**KIT# 524429-1**

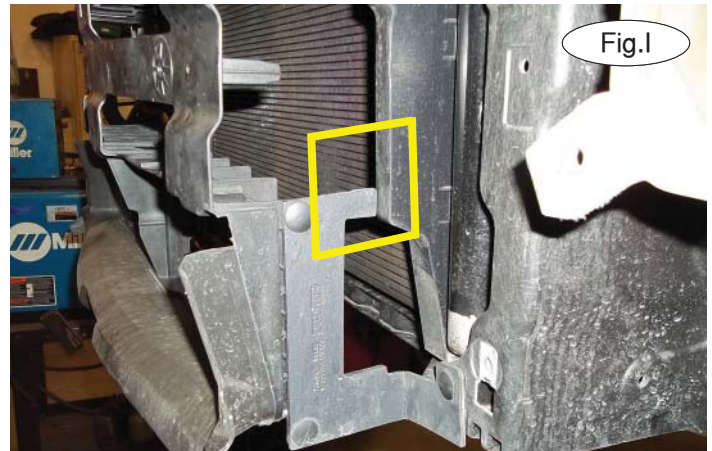

5. On the backside of the louver housing, firmly squeeze together to release two clips in the bottom and one clip on top attaching the louver alignment bar to the louvers (Fig.H).

6. Trim the air deflectors using the yellow lines as a guide for trimming (Fig.I – driver's side) (Fig.J – passenger side).

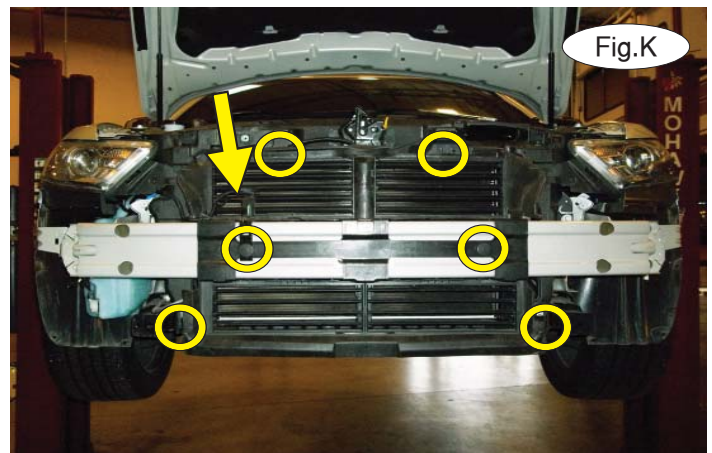

7. Remove the wiring harness and ambient temperature sensor from the louver housing as indicated by the arrow in Figure K. Now, release two clips on top; two 8mm screws in the middle, and two plastic fasteners on the bottom to remove the louver housing (Fig.K).

8. On each side, remove four 13mm (head) bolts attaching the bumper core to the frame rails (Fig.L). The bumper core will not be replaced. *Note:* retain the bumper core and attachment hardware for replacement in case the bracket is ever removed.

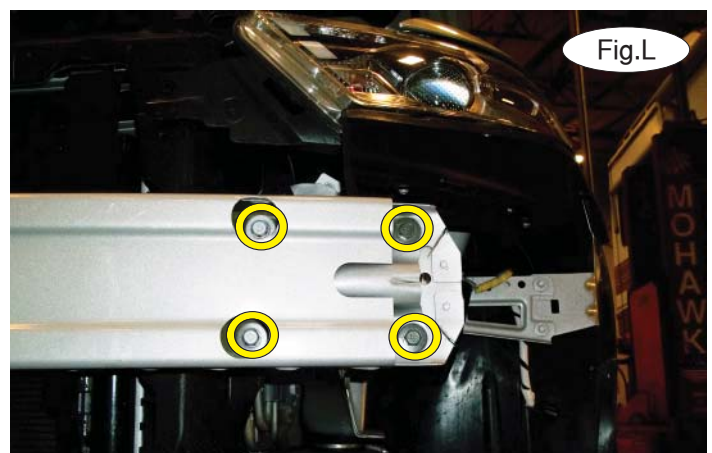



# MOUNTING BRACKET KIT INSTALLATION INSTRUCTIONS

**KIT# 524429-1**

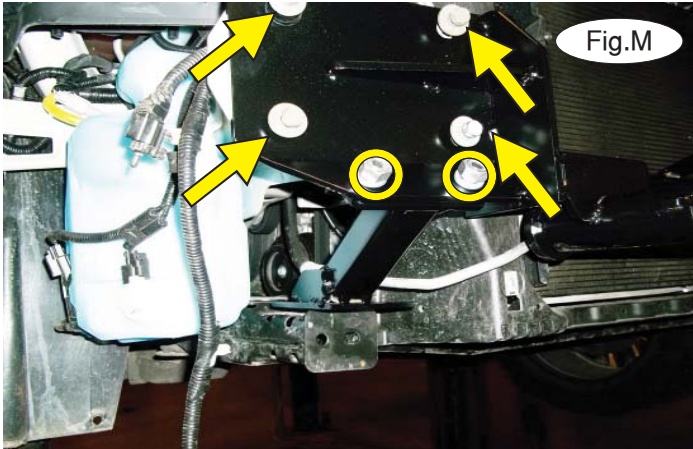

9. Place the main receiver brace over the frame rails and bolt each side into place using the hardware from the previous step (Fig.M – indicated by arrows). *Note:* ensure proper alignment, as the bolts will receive Loctite® Red and will be torqued at the end of these instructions.

Now, align the holes in the support brace with the lower holes in the main receiver brace and ensuring that the lower hole of the support brace aligns with the existing hole in the subframe, bolt the two together on each side using the two supplied  $\frac{1}{2}$ " x  $1\frac{1}{4}$ " bolts,  $\frac{1}{2}$ " lock washers and  $\frac{1}{2}$ " nuts (Fig.M – indicated by circles).

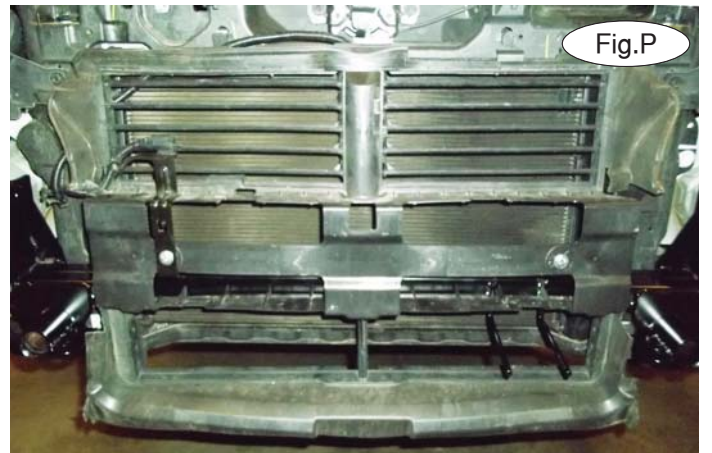

10. On each side, place a  $\frac{1}{4}$ " x 1" O.D. x .188 wall pipe spacer between the subframe and the rear support and then placing one of the pipe spacers over one of the supplied  $\frac{1}{2}$ " x  $3\frac{1}{2}$ " bolts, bolt up through the subframe, pipe spacer, support brace and finish with a  $\frac{1}{2}$ " lock washer and nut (Fig.N).

11. On the back of the louver housing, use a flathead screwdriver to pop out the center hinges and then pull out the hinge pins on each side to remove the lower four louvers (Fig.O).

12. Reversing step 7, reinstall the louver housing and reattach the main center mounts of the louver housing and the ambient temperature sensor using, on each side,  $\frac{1}{4}$ " x 1" bolt, two  $\frac{1}{4}$ " flat washers and a nut (Fig.P).





# MOUNTING BRACKET KIT INSTALLATION INSTRUCTIONS

**KIT# 524429-1**

Fig.Q



Fig.R



13. Cut out the template found at the end of these instructions and align it on each side of the grille, using Figure Q as a reference. Use a center punch to mark the grille for trimming. Reinstall the trimmed grille back into the fascia (Fig.R).

14. Tighten all bolts to the bolt torque requirements found at the end of these instructions. *Note:* use Loctite® Red on all nuts and bolts.

15. Reinstall the fascia, reversing steps 1-4 (Fig.S).

16. Insert the removable front bracket arms into the front receiver braces, and twist each one 90 degrees to lock.

17. Install the tow bar to the mounting bracket according to the manufacturer's instructions.

Fig.S



### **IMPORTANT!**

**Safety cables are required by law. When towing, connect safety cables to the safety cable tabs illustrated on page 1. Make certain there is adequate slack in the cables to allow a full turning radius; otherwise, damage will result. If necessary, longer cables or cable extensions are available.**

*Note:* if the bracket is so equipped, the holes in the alignment tabs which are welded to the arms and main receiver braces are for padlocks only. Under no circumstances should you bolt the alignment tabs together. Bolting the alignment tabs together may result in non-warranty damage to the bracket.



# MOUNTING BRACKET KIT INSTALLATION INSTRUCTIONS

**KIT# 524429-1**

## Three options for attaching the wiring plug to the main receiver brace

**For six-wire plugs:** use the two supplied 3/4" self-tapping screws to attach the electrical plug directly to the rods on the front of the main receiver brace.

**For four-wire round plugs:** attach to the plug mounting plate and then use the two supplied 3/4" self-tapping screws to attach the mounting plate to the rods on the front of the main receiver brace.

**For four-wire flat plugs:** place the plug through the mounting plug plate, and then secure it using the supplied zip tie on the front of the plug (Fig.T). Use the two supplied 3/4" self-tapping screws to attach the mounting plate to the rods on the front of the main receiver brace.

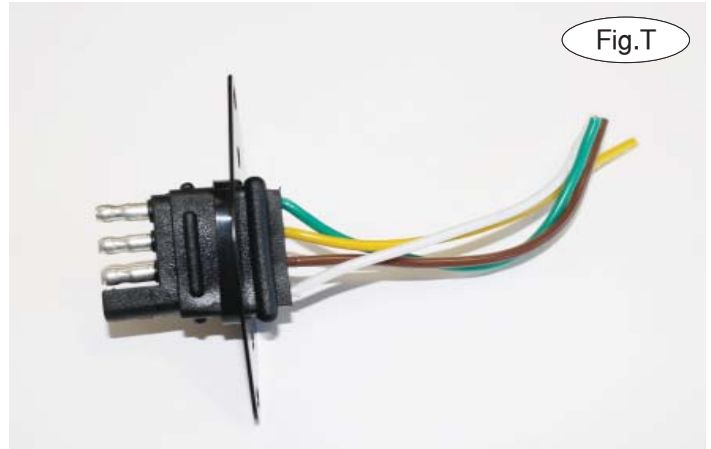

Fig.T

## BOLT TORQUE REQUIREMENTS

Note: The torque values represented below are intended as general guidelines. Torque requirements for specific applications may vary. Roadmaster does not warrant this information to be accurate for all applications and disclaims all liability for any claims or damages which may result from its use.

### STANDARD BOLTS

Thread Size	Grade	Torque
5/16.....	5.....	13 ft./lb.
3/8.....	5.....	23 ft./lb.
7/16.....	5.....	37 ft./lb.
1/2.....	5.....	56 ft./lb.
5/8.....	5.....	150 ft./lb.

### METRIC BOLTS

Thread Size	Grade	Plated / Unplated
8mm-1.0 .....	8.8 .....	20 ft./lb. 18 ft./lb.
8mm-1.25 .....	8.8 .....	19 ft./lb. 18 ft./lb.
10mm-1.25 .....	8.8 .....	38 ft./lb. 36 ft./lb.
10mm-1.5 .....	8.8 .....	37 ft./lb. 35 ft./lb.

### METRIC BOLTS

Thread Size	Grade	Plated / Unplated
12mm-1.25 .....	8.8 .....	70 ft./lb. 65 ft./lb.
12mm-1.5 .....	8.8 .....	66 ft./lb. 61 ft./lb.
12mm-1.75 .....	8.8 .....	65 ft./lb. 60 ft./lb.
14mm-2.0 .....	8.8 .....	104 ft./lb. 97 ft./lb.

**KIT# 524429-1**

