

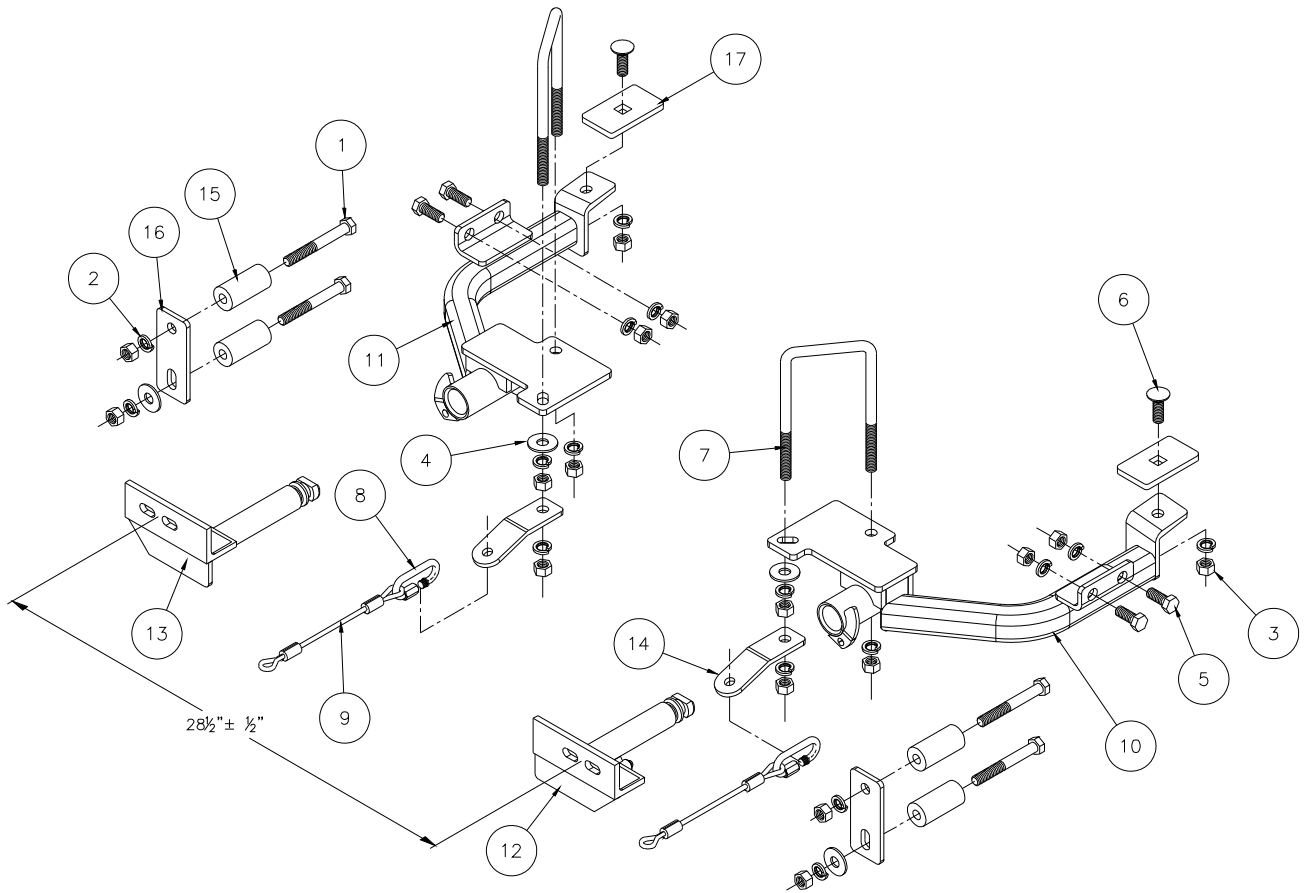

MOUNTING BRACKET KIT KIT #523120-1 INSTALLATION INSTRUCTIONS



ITEM	QTY	Length	Width	NAME	MATERIAL
1	4	4"	1/2"	BOLT	350105-00
2	16		1/2"	LOCK WASHER	350309-00
3	16		1/2"	NUT	350258-00
4	4		1/2"	FLAT WASHER	350308-20
5	4	1 1/4"	1/2"	BOLT	350094-10
6	2	1 1/2"	1/2"	CARRIAGE BOLT	350362-00
7	2	7"	1/2"	1/2" x 3 5/8" x 7" UBOLT	357360-00
8	2			CABLE CONNECTOR	200008-00
9	2	8"		CABLE	500646-08
10	1			DRIVER SIDE RECEIVER	C-000734
11	1			PASSENGER SIDE RECEIVER	C-000735
12	1			DRIVER SIDE ARM	C-000736
13	1			PASSENGER SIDE ARM	C-000737
14	2			CABLE TAB	B-000508
15	4			1 1/4" O.D. x 2 5/8" x 0.250 WALL ROUND TUBE	A-001246
16	2			1/4" x 2" x 4 3/4" BACKING PLATE	A-001247
17	2			1/4" x 1 3/4" x 3" SQ. HOLE BACKING PLATE	A-001248



MOUNTING BRACKET KIT INSTALLATION INSTRUCTIONS

KIT #523120-1

This bracket kit is one of our EZ series, which is designed to be partly removable. The kit consists of two main receiver braces, two front arm braces, a cross bar, two cable mounts and a hardware pack.

The main receiver braces bolt to the side of the frame and the bumper core. The cross brace bolts between the main receiver braces. The front braces insert into the receivers on each side, then rotate 90 degrees to automatically lock (Fig.A).

Start by laying the kit out according to the illustration. This will give you a visual idea of how the kit installs and also confirm that the kit components are present and accounted for.



Fig.A

IMPORTANT: All brackets **must** be assembled with all the bolts left loose for final adjustment and positioning (before tightening) unless otherwise instructed. All bolts **must** be torqued for proper strength. If more than one bolt is used per fastening point, the diagram may only show one.

- Use flat washers over all slotted holes
- Use lock washers on all fasteners

ROADMASTER Limited Warranty, including One-Year Conditional Warranty Text and Product Registration Card, in Carton.

WARNING

Failure to follow these instructions can result in property damage, personal injury or even death.

- Installation of most mounting brackets requires moderate mechanical aptitude and skills. We strongly recommend professional installation by an experienced installer.
- The installer must read the instructions and use all bolts and parts supplied. Failure to do so could result in loss of the towed vehicle.
- Use Loctite® Red on all bolts used for mounting this bracket.
- Do not use this document for custom fabrication, as it may not show all parts or structural components. Custom fabrication or an attempt to copy this bracket design could result in loss of the towed vehicle.
- Every 3,000 miles, the owner must inspect the fasteners for proper torque, according to the bolt torque requirements chart on the last page of these instructions. The owner must also inspect all mounts and brackets for cracks or other signs of fatigue every 3,000 miles. Failure to do so could result in loss of the towed vehicle.
- The owner must check the vehicle manufacturer's instructions for the proper procedure(s) to prepare the vehicle for towing. Some vehicles must be equipped with a transmission lube pump, an axle disconnect, driveline disconnect or free-wheeling hubs before they can be towed. Failure to properly equip the vehicle will cause severe damage to the transmission.
- If running changes were made by the vehicle manufacturer after this bracket was designed, some bolts or other fasteners in the hardware pack may no longer be the correct size. It is the installer's responsibility to verify that the bracket is securely fastened to the vehicle and fitted with the correct hardware to account for these changes. Failure to securely fasten the bracket could result in loss of the towed vehicle.
- If the towed vehicle has been in an accident, it must be properly repaired before attaching the bracket. Do not install the bracket if any structural frame damage is found. Failure to repair the damage could result in the loss of the towed vehicle.
- Some motorhome chassis have such a tight turning radius that you can damage your motorhome, towed vehicle, tow bar or bracket while turning sharply. Before getting on the road, test your turning radius in an empty parking lot. Turning too sharply could result in non-warranty damage to towing system, motorhome and/or towed vehicle.
- Do not back up with the towed vehicle attached or non-warranty damage will occur to your towing system, motorhome and/or towed vehicle.
- The safety cables must connect the towing vehicle to the towed vehicle frame to frame, with the cables crossed, with enough slack for sharp turns. Refer to the cable instructions for proper routing. Failure to leave enough slack in the safety cables, or failure to connect the safety cables frame to frame, will result in the loss of the towed vehicle.
- This bracket is designed for use with ROADMASTER tow bars and ROADMASTER adaptors only. Using this bracket with other brands, without an approved ROADMASTER adaptor, may result in non-warranty damage or injury.
- Upon final installation, the installer must inspect the bracket to ensure adequate clearance, particularly around hoses, air conditioner lines, radiators, etc., or non-warranty damage to the towed vehicle will result.
- This bracket is only warranted for the original installation. Installing a used bracket on another vehicle is not recommended and will void the warranty.



MOUNTING BRACKET KIT INSTALLATION INSTRUCTIONS

KIT #523120-1



Fig.B

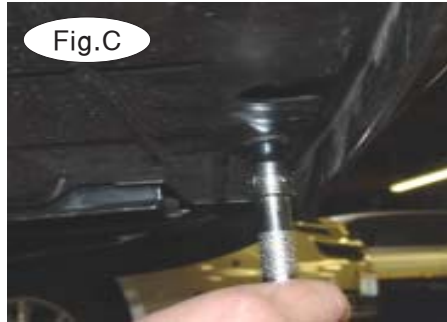

Fig.C



Fig.D

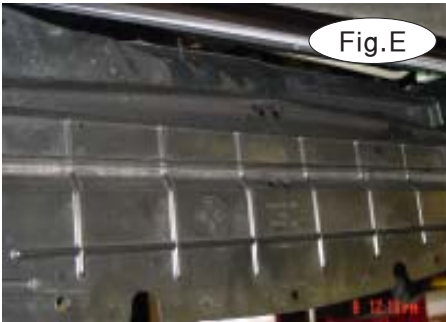

Fig.E



Fig.F



Fig.G

1. **Important:** please use all supplied bolts and parts and read all instructions carefully before beginning this installation. The majority of questions you may have can be answered within the text, and proper installation will ensure safe and secure travel. Now, begin the installation. Starting at the top of the fascia, remove four plastic fasteners (Fig.B). *Note:* the number of plastic fasteners may vary on 2006 models.



Fig.H



Fig.I

2. Move beneath the fascia and remove five 7mm (head) screws from the center of the fascia (Fig.C) and four plastic fasteners from the bottom of the fascia. Then pull the center splash panel loose, and leave it hanging (Fig.D,E). *Note:* the number of plastic fasteners may vary on 2006 models.
3. Remove two more plastic fasteners under the bumper core (Fig.F).
4. Remove all plastic fasteners from the driver side and the passenger side fender wells. Then, remove the front splash panel on both sides (Fig.G,H,I).



MOUNTING BRACKET KIT INSTALLATION INSTRUCTIONS

KIT #523120-1

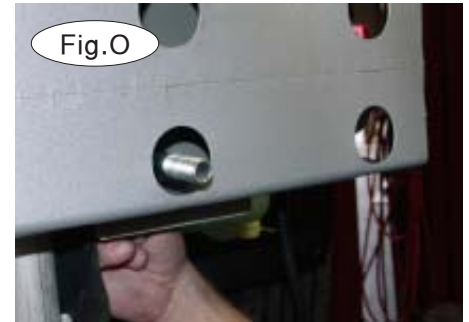
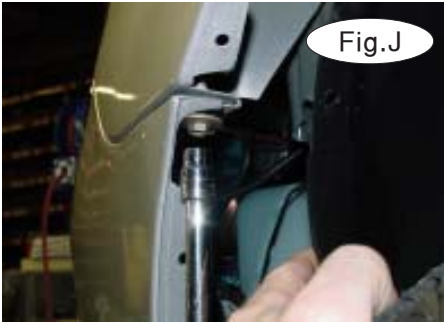

5. Remove one 10mm (head) fastener at the fascia fender well junction on each side (Fig.J).
6. Remove the fascia by pulling out on the sides and forward (Fig.K).
7. Remove the radiator side panels on each side (Fig.L,M).
8. Looking at the front of the bumper core, find four large holes on each side. Locate the inner two holes on each side and drill 17/32" holes through the middle of each hole through the back of the bumper core (Fig.N). *Note: each of the holes should have a spot weld in the middle of the hole – just center punch it, and drill.*
9. Insert 1/2" x 4" bolts and flat washers into the drilled holes (Fig.O), then bolt through the bumper core, two 5/8" pipe spacers and front backing plate with 1/2" x 4" bolts, flat washers, lock washers and nuts (Fig.P,Q). Tighten these bolts to the torque specifications on the last page.
10. Now pop the wiring harness loose on the top of the bumper core (Fig.R).
11. Put U-bolts over the bumper core on each side, as shown on the next page (Fig.S).

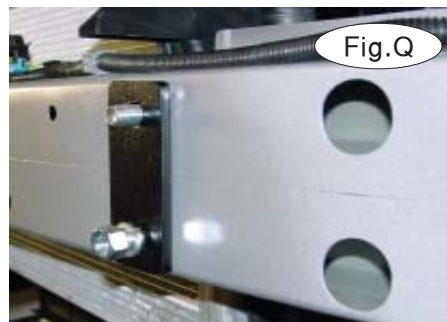



MOUNTING BRACKET KIT INSTALLATION INSTRUCTIONS

KIT #523120-1

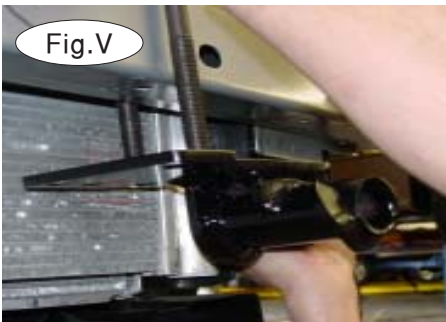

12. Working on one side at a time, locate the square hole in the bottom of each frame and insert a $\frac{1}{2}$ " x $1\frac{1}{2}$ " carriage bolt and $\frac{1}{4}$ " x $1\frac{3}{4}$ " x 3" backing plate into the frame as shown in Figures T and U.
13. Hold the brace in place under the bumper core and the frame with the rear mount on the previously-installed carriage bolt and the front of the brace on the U-bolt (Fig.V). Secure the brace in place with three $\frac{1}{2}$ " nuts, lock washers and two additional flat washers on the front of the U-bolt (Fig.W).
14. Repeat for the remaining side (Fig.X).
15. Align the braces so the middle flange is flush against the frame flange on each side, then tighten in place (Fig.X). Using the drawing on the first page as a reference, measure between the two front braces, ensuring that the distance is still 28" +/- $\frac{1}{2}$ ".
16. Using the receiver braces as drill templates, drill two holes per side through the lower frame flange on each side (Fig.Y).
17. Bolt through on each side with two $\frac{1}{2}$ " x $1\frac{1}{4}$ " bolts, lock washers and nuts (Fig. Z).
18. Torque the U-bolts to 45 ft. lbs. Torque the mounting bolts to the torque specifications on the last page of these instructions. Recheck the measurements, to make certain this distance is still 28" +/- $\frac{1}{2}$ ".





MOUNTING BRACKET KIT INSTALLATION INSTRUCTIONS

KIT #523120-1

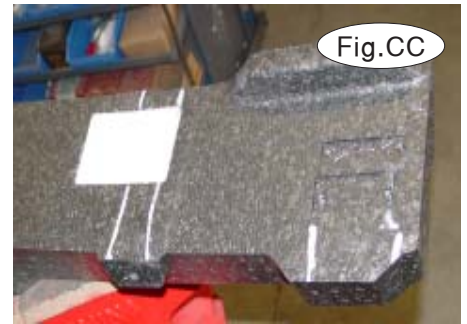
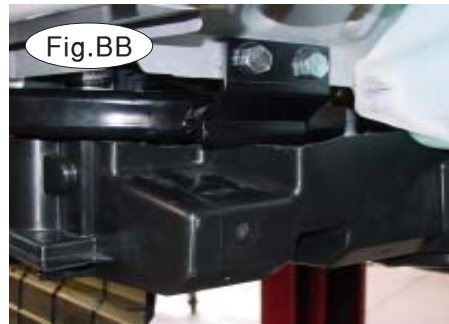

19. Trim the side air deflectors to fit around the receiver brace (Fig. AA, BB).

20. Remove the shock absorption foam from the fascia (two screws) then trim the foam to fit around the mounting U-bolts and receiver brace (Fig. CC, DD).

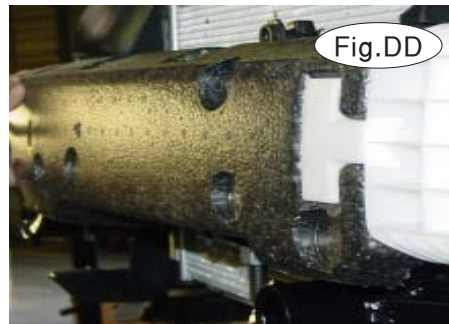

21. Cut the center rib from each side of the front grille as shown (Fig. EE). *Note:* for 2006 models, hold the grille up to the receivers, mark the grille and trim to allow access for the receivers. For all models except the 2008 Malibu Maxx SS, skip to step 22.

Trimming for the 2007 Malibu Maxx SS only

For 2007 Malibu Maxx SS models, use the yellow guide lines in Figure GG for trimming. Test fit over the receivers and trim an additional amount, if needed, to provide clearance for the main receiver braces (Fig. HH). Figure II shows the fascia's fit over the receiver braces. Now, move to step 22.



22. Install the shock absorption foam in the fascia with retainer screws (Fig. JJ).

23. Replace the fascia and splash panels, reversing steps 1 through 6.

24. Install the safety cable mounting tabs on the mounting U-bolt with nuts and lock washers, as shown in Figure KK.





MOUNTING BRACKET KIT INSTALLATION INSTRUCTIONS

KIT #523120-1

25. Insert the front braces into the receiver braces (Fig.LL) and turn 90 degrees to lock (Fig.MM).
26. Install the safety cables and connectors.
27. Attach the ends of the 8" safety cables to the front holes in the cable mounting tabs (located on the inside of the receiver braces) with the included cable connectors (Fig.NN). Connect the other end to the tow vehicle's safety cables and tow bar.
28. Torque all mounting bolts to the specifications below.



BOLT TORQUE REQUIREMENTS

Note: The torque values represented below are intended as general guidelines. Torque requirements for specific applications may vary. Roadmaster does not warrant this information to be accurate for all applications and disclaims all liability for any claims or damages which may result from its use.

STANDARD BOLTS

Thread Size	Grade	Torque
5/16	5	13 ft./lb.
3/8	5	23 ft./lb.
7/16	5	37 ft./lb.
1/2	5	56 ft./lb.
5/8	5	150 ft./lb.

METRIC BOLTS

Thread Size	Grade	Plated/Unplated
8mm-1.0	8.8	20 ft./lb. 18 ft./lb.
8mm-1.25	8.8	19 ft./lb. 18 ft./lb.
10mm-1.25	8.8	38 ft./lb. 36 ft./lb.
10mm-1.5	8.8	37 ft./lb. 35 ft./lb.

METRIC BOLTS

Thread Size	Grade	Plated/Unplated
12mm-1.25	8.8	70 ft./lb. 65 ft./lb.
12mm-1.5	8.8	66 ft./lb. 61 ft./lb.
12mm-1.75	8.8	65 ft./lb. 60 ft./lb.
14mm-2.0	8.8	104 ft./lb. 97 ft./lb.

All illustrations and specifications contained herein are based on the latest information available at the time of publication approval. ROADMASTER, INC. reserves the right to make changes at any time without notice in material, specification and models or to discontinue models.