

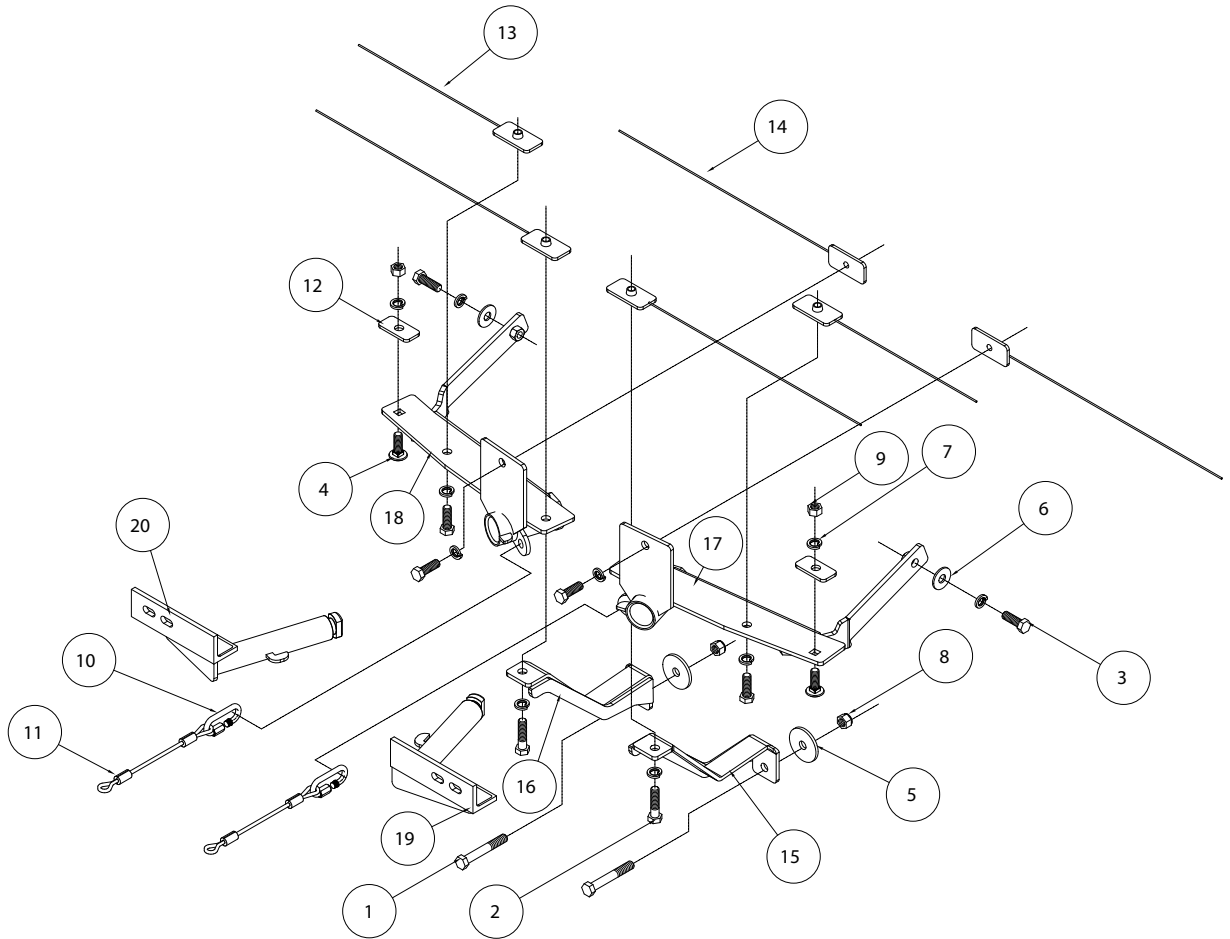

MOUNTING BRACKET KIT KIT# 521441-1

INSTALLATION INSTRUCTIONS



ITEM	QTY	NAME	MATERIAL
1.....2	2	1/2" x 3 1/2" BOLT	350103-00
2.....2	2	1/2" x 2" BOLT	350097-00
3.....6	6	1/2" x 1 1/2" BOLT	350095-00
4.....2	2	1/2" x 1 1/2" CARRIAGE BOLT	350093-00
5.....2	2	1/2" PLATE WASHER	A-003086
6.....2	2	1/2" FLAT WASHER	350308-00
7.....10	10	1/2" LOCK WASHER	350309-00
8.....2	2	1/2" NYLOCK NUT	350259-00
9.....2	2	1/2" HEX NUT	350258-00
10.....2	2	QUICK LINK	200008-00
11.....2	2	SAFETY CABLES 8"	500646-08
12.....2	2	3/16" x 1 1/4" x 2 1/2" BACKING PLATE	A-000228
13.....2	2	3/16" x 1 1/2" x 3" THREADED BACKING PLATE W/ 12" ROD	C-002006
14.....4	4	3/16" x 1 1/2" x 3" THREADED BACKING PLATE W/ 18" ROD	C-002135
15.....1	1	DRIVER SIDE BRACE	C-002128
16.....1	1	PASSENGER SIDE BRACE	C-002129
17.....1	1	DRIVER SIDE RECEIVER	C-002130
18.....1	1	PASSENGER SIDE RECEIVER	C-002131
19.....1	1	DRIVER SIDE ARM	C-002132
20.....1	1	PASSENGER SIDE ARM	C-002133
21.....3	3	ZIP TIE	300140-10



MOUNTING BRACKET KIT INSTALLATION INSTRUCTIONS

KIT# 521441-1

This is one of our EZ series brackets, which allows the visible front portion of the bracket to be easily removed from the front of the vehicle (Fig.A and Fig.B). The bracket consists of two main receiver braces, two removable lower braces and a hardware pack.

Before starting the installation, lay out the kit components in order, as they will be used. This will give you a visual idea of how the components work, and will also confirm that everything is present and accounted for.



Fig.A



Fig.B

IMPORTANT: All brackets **must** be assembled with all the bolts left loose for final adjustment and positioning (before tightening) unless otherwise instructed. All bolts **must** be torqued for proper strength. If more than one bolt is used per fastening point, the diagram may only show one.

- Use flat washers over all slotted holes
- Use lock washers on all fasteners

ROADMASTER Limited Warranty, including One-Year Conditional Warranty Text and Product Registration Card, in Carton.

WARNING

Failure to follow these instructions can result in property damage, personal injury or even death.

- Installation of most mounting brackets requires moderate mechanical aptitude and skills. We strongly recommend professional installation by an experienced installer.
- The installer must read the instructions and use all bolts and parts supplied. Failure to do so could result in loss of the towed vehicle.
- Use Loctite® Red on all bolts used for mounting this bracket.
- Every 3,000 miles, the owner must inspect the fasteners for proper torque, according to the bolt torque requirements chart on the last page of these instructions. The owner must also inspect all mounts and brackets for cracks or other signs of fatigue every 3,000 miles. Failure to do so could result in loss of the towed vehicle.
- The owner must check the vehicle manufacturer's instructions for the proper procedure(s) to prepare the vehicle for towing. Some vehicles must be equipped with a transmission lube pump, an axle disconnect, driveline disconnect or free-wheeling hubs before they can be towed. Failure to properly equip the vehicle will cause severe damage to the transmission.
- If running changes were made by the vehicle manufacturer after this bracket was designed, some bolts or other fasteners in the hardware pack may no longer be the correct size. It is the installer's responsibility to verify that the bracket is securely fastened to the vehicle and fitted with the correct hardware to account for these changes. Failure to securely fasten the bracket could result in loss of the towed vehicle.
- If the towed vehicle has been in an accident, it must be properly repaired before attaching the bracket. Do not install the bracket if any structural frame damage is found. Failure to repair the damage could result in the loss of the towed vehicle.
- Roadmaster manufactures many styles of brackets. If your bracket has removable arms, they must be removed before driving the vehicle, unless the arms can be pinned or padlocked in place. If not secured, the arms could vibrate out, resulting in non-warranty damage or personal injury.
- Some motorhome chassis have such a tight turning radius that you can damage your motorhome, towed vehicle, tow bar or bracket while turning sharply. Before getting on the road, test your turning radius in an empty parking lot. Turning too sharply could result in non-warranty damage to towing system, motorhome and/or towed vehicle.
- Do not back up with the towed vehicle attached or non-warranty damage will occur to your towing system, motorhome and/or towed vehicle.
- The safety cables must connect the towing vehicle to the towed vehicle frame to frame, with the cables crossed, with enough slack for sharp turns. Refer to the cable instructions for proper routing. Failure to leave enough slack in the safety cables, or failure to connect the safety cables frame to frame, will result in the loss of the towed vehicle.
- This bracket is designed for use with ROADMASTER tow bars and ROADMASTER adaptors only. Using this bracket with other brands, without an approved ROADMASTER adaptor, may result in non-warranty damage or injury.
- Do not use this document for custom fabrication, as it may not show all parts or structural components. Custom fabrication or an attempt to copy this bracket design could result in loss of the towed vehicle.
- Upon final installation, the installer must inspect the bracket to ensure adequate clearance, particularly around hoses, air conditioner lines, radiators, etc., or non-warranty damage to the towed vehicle will result.
- This bracket is only warranted for the original installation. Installing a used bracket on another vehicle is not recommended and will void the warranty.



MOUNTING BRACKET KIT INSTALLATION INSTRUCTIONS

KIT# 521441-1



1. **Important:** please use all supplied bolts and parts and read all instructions carefully before beginning this installation. The majority of questions you may have can be answered within the text, and proper installation will ensure safe and secure travel. Now, begin the installation. Remove seven T20 Torx bolts and two 10mm (head) bolts (Fig.C).



2. On each side, remove three 7mm (head) screws attaching the fascia to the fender liner (Fig.D).
3. On each side, remove two plastic fasteners attaching the fender liner to the lower fascia (Fig.E).
4. On each side, pull back the fender liner and remove one 7mm (head) bolt attaching the corner of the fascia to the fender (Fig.F).
5. Disconnect the fog lights and side marker lights.
6. Remove two plastic clips attaching the lower fascia to the lower radiator support (Fig.G).

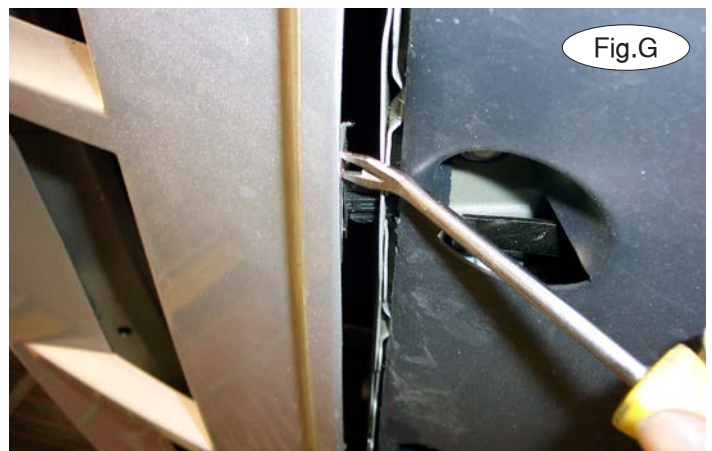



MOUNTING BRACKET KIT INSTALLATION INSTRUCTIONS

KIT# 521441-1



Fig.H

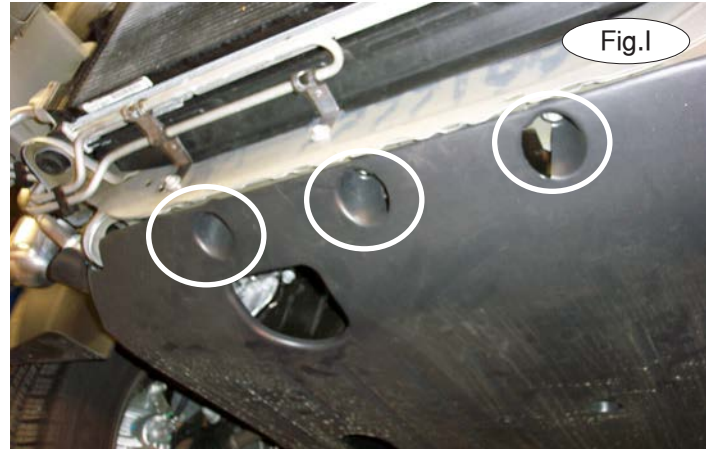

Fig.I

7. Push down on the fascia directly in front of the turn signals and pull it forward to remove it (Fig.H). *Note:* the plastic locking track above the turn signal must clear the front edge of the fender.

8. Remove three 10mm (head) screws attaching the center splash shield to the radiator support (Fig.I) and two plastic fasteners on each side attaching it to the frame rail (Fig.J). *Note:* let the shield hang straight down for now.



Fig.J

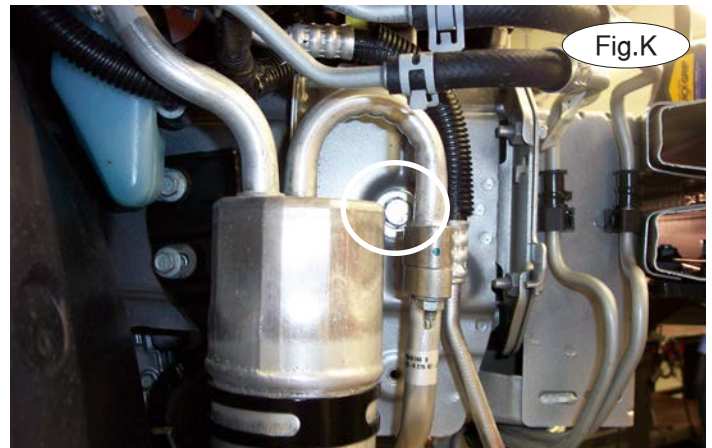

Fig.K

9. Working on the passenger side only, place the rear mount of the main receiver brace through the opening in the bumper core and align it with the pre-existing hole in the side of the frame rail. Place one of the supplied $\frac{1}{2}$ " lock washers and flat washers over one of the $\frac{1}{2}$ " x $1\frac{1}{2}$ " bolts and bolt through the frame rail and main receiver brace (Fig.K). Now, clamp the receiver to the bumper core, making certain that the two outer holes of the main receiver brace align with the pre-existing holes in the bumper core and enlarge them to $\frac{1}{2}$ " (Fig.L).



Fig.L



MOUNTING BRACKET KIT INSTALLATION INSTRUCTIONS

KIT# 521441-1



Fig.M

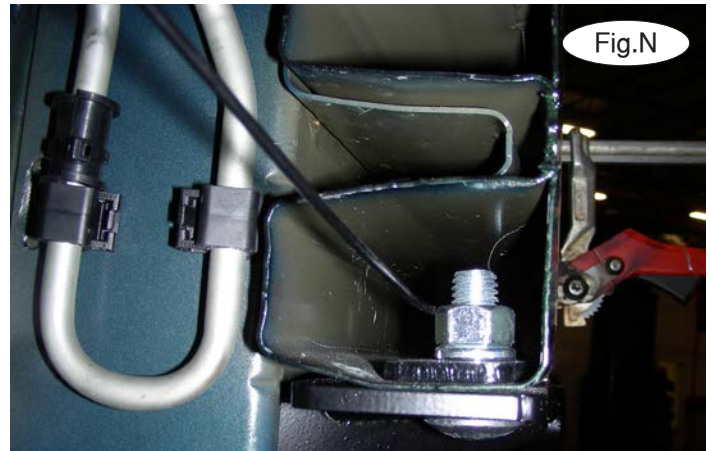

Fig.N

10. Place a 1½" x 3" nutted backing plate with short wire inside the bumper core over the center hole of the main receiver brace. Bolt through the main receiver brace, bumper core and into the backing plate using a ½" x 1½" bolt and lock washer (Fig.M).

11. Place a 1½" x 3" backing plate over the outermost hole inside the bumper core, then using one of the supplied ½" x 1½" carriage bolts, bolt through the main receiver brace, bumper core, backing plate and finish with a ½" lock washer and nut. (Fig.N).

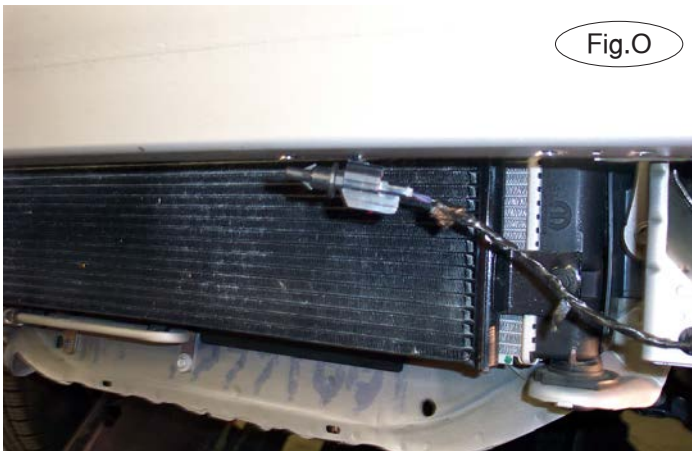

Fig.O



Fig.P

12. Disconnect the ambient temperature sensor (Fig.O). Then, repeat steps 9 through 11 for the driver's side.

13. Working on the passenger side, and using the inner holes on the bottom of the main receiver brace as a template, drill a ½" hole through the bumper core (Fig.P).

14. Place a 1½" x 3" backing plate with long wire inside the bumper core over the hole drilled in step 13. Place the lower brace over the inner mounting point and bolt through the lower brace, main receiver brace, bumper core, and into the backing plate using a ½" x 1½" bolt and lock washer (Fig.Q).



Fig.Q



MOUNTING BRACKET KIT INSTALLATION INSTRUCTIONS

KIT# 521441-1



15. Starting with the lower mounting points, tighten the bolts to the bolt torque requirements found at the end of this document. *Note:* make certain the lower mounting points of the lower braces are flush against the lower radiator support. The lower mounting points of the main receiver brace will secure the power steering mount in place (Fig.R). *Note:* due to manufacturing variances, the power steering mount may not be present.

16. Using the upper mounting points on the main receiver brace as templates, drill $\frac{1}{2}$ " holes through the face of the bumper core (Fig.S).



17. Using a $\frac{1}{2}$ " x $1\frac{1}{2}$ " bolt and lock washer, bolt through the main receiver brace and bumper core and into a $1\frac{1}{2}$ " x 3" backing plate with long wire. Torque to the bolt torque requirements found at the end of this document.

18. Using the holes in the lower brace as templates, drill through the front and back of the radiator support (Fig.T). *Note:* before drilling, make certain you will not drill through any engine components.

19. Bolt through the lower brace and core support using a $\frac{1}{2}$ " x $3\frac{1}{2}$ " bolt, plate washer and Nylock nut (Fig.U). The plate washer should be placed on the rear of the core support. Torque the nut to 25 ft./lbs.

20. Repeat steps 13 through 19 for the driver's side.

21. Relocate the ambient temperature sensor to the bottom of the bumper core using the pre-existing wiring support clip (Fig.V).





MOUNTING BRACKET KIT INSTALLATION INSTRUCTIONS

KIT# 521441-1

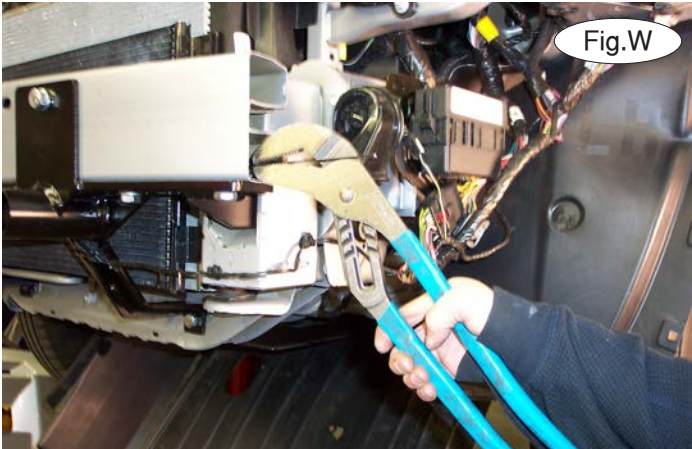

22. Using a pair of pliers, break the wires off all the backing plates (Fig.W).
23. Remove the foam shock absorption pad (Fig.X). It will not be replaced. *Note:* retain the foam shock absorption pad for reinstallation in case the bracket is ever removed.

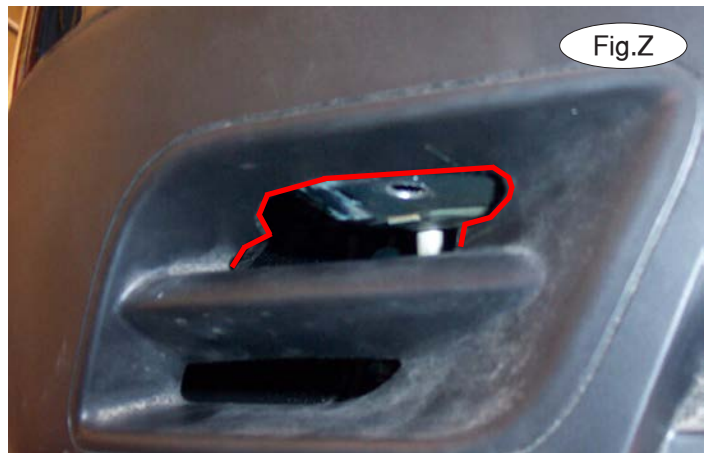

24. Hold the fascia in place and mark it for trimming. Trim the fascia using the red lines in Figures Y and Z as a reference for trimming.
25. Reinstall the fascia, reversing steps 1 through 7.
26. Attach the 8" safety cables with the cable connectors (Q-Links) to the front of the receiver braces.
27. Insert the removable front bracket arms into the front receiver braces, and twist each one 90 degrees to lock (Fig.AA).
28. Attach the ends of the safety cables to the tow vehicle's safety cables.
29. Install the tow bar to the mounting bracket according to the manufacturer's instructions.

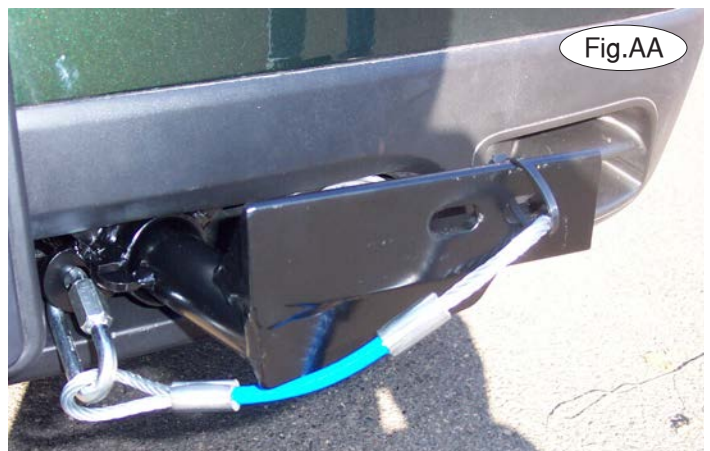



MOUNTING BRACKET KIT INSTALLATION INSTRUCTIONS

KIT# 521441-1

BOLT TORQUE REQUIREMENTS

Note: The torque values represented below are intended as general guidelines. Torque requirements for specific applications may vary. Roadmaster does not warrant this information to be accurate for all applications and disclaims all liability for any claims or damages which may result from its use.

STANDARD BOLTS

Thread Size	Grade	Torque
5/16.....	5.....	13 ft./lb.
3/8.....	5.....	23 ft./lb.
7/16.....	5.....	37 ft./lb.
1/2.....	5.....	56 ft./lb.
5/8.....	5.....	150 ft./lb.

METRIC BOLTS

Thread Size	Grade	Plated / Unplated
8mm-1.0.....	8.8.....	20 ft./lb. 18 ft./lb.
8mm-1.25.....	8.8.....	19 ft./lb. 18 ft./lb.
10mm-1.25.....	8.8.....	38 ft./lb. 36 ft./lb.
10mm-1.5.....	8.8.....	37 ft./lb. 35 ft./lb.

METRIC BOLTS

Thread Size	Grade	Plated / Unplated
12mm-1.25.....	8.8.....	70 ft./lb. 65 ft./lb.
12mm-1.5.....	8.8.....	66 ft./lb. 61 ft./lb.
12mm-1.75.....	8.8.....	65 ft./lb. 60 ft./lb.
14mm-2.0.....	8.8.....	104 ft./lb. 97 ft./lb.

All illustrations and specifications contained herein are based on the latest information available at the time of publication approval. ROADMASTER, INC. reserves the right to make changes at any time without notice in material, specification and models or to discontinue models.