

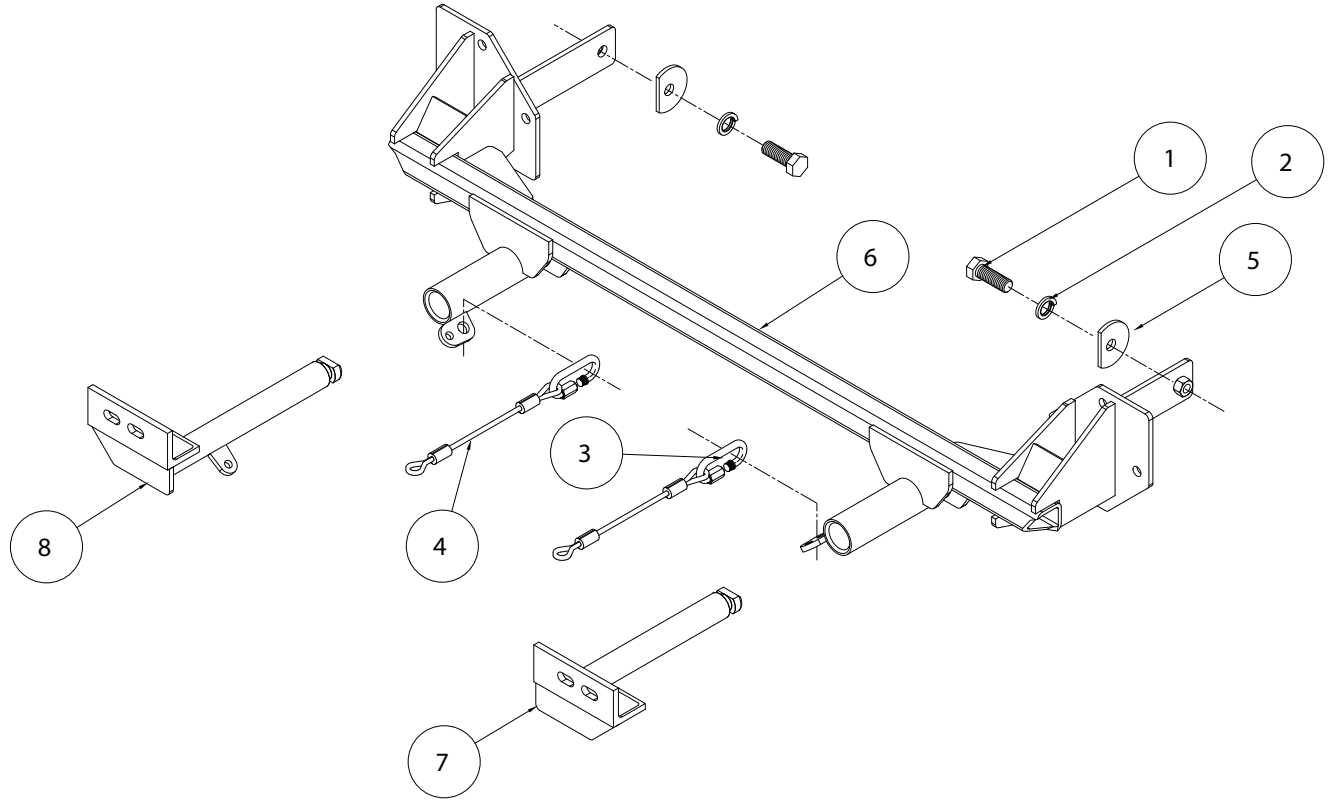

MOUNTING BRACKET KIT *KIT# 521190-1*
INSTALLATION INSTRUCTIONS



ITEM	QTY	NAME	MATERIAL
1.....	2	1/2" x 1 3/4" BOLT.....	350096-00
2.....	2	1/2" LOCK WASHER	350309-00
3.....	2	QUICK LINK.....	200008-00
4.....	2	SAFETY CABLE 8"	650646-08
5.....	2	1/2" CLIPPED PLATE WASHER.....	A-002687
6.....	1	MAIN RECEIVER.....	C-001747
7.....	1	DRIVER SIDE ARM	C-001748
8.....	1	PASSENGER SIDE ARM.....	C-001749



MOUNTING BRACKET KIT INSTALLATION INSTRUCTIONS

KIT# 521190-1

This is one of our EZ2 series brackets, which allows the visible front portion of the bracket to be easily removed from the front of the vehicle (Fig.A and Fig.B). The bracket consists of a main receiver brace, two removable front braces, two center braces and a hardware pack.

The main receiver brace mounts to the frame rails and the bumper core. The removable front braces install in the main receiver brace.

Before starting the installation, lay out the kit components in order, as they will be used. This will give you a visual idea of how the components work, and will also confirm that everything is present and accounted for.



Fig.A



Fig.B

IMPORTANT: All brackets **must** be assembled with all the bolts left loose for final adjustment and positioning (before tightening) unless otherwise instructed. All bolts **must** be torqued for proper strength. If more than one bolt is used per fastening point, the diagram may only show one.

- Use flat washers over all slotted holes
- Use lock washers on all fasteners

ROADMASTER Limited Warranty, including One-Year Conditional Warranty Text and Product Registration Card, in Carton.

WARNING

Failure to follow these instructions can result in property damage, personal injury or even death.

- **Installation of most mounting brackets requires moderate mechanical aptitude and skills.** We strongly recommend professional installation by an experienced installer.
- **The installer must read the instructions and use all bolts and parts supplied.** Failure to do so could result in loss of the towed vehicle.
- **Use Loctite® Red** on all bolts used for mounting this bracket.
- **Every 3,000 miles, the owner must inspect the fasteners** for proper torque, according to the bolt torque requirements chart on the last page of these instructions. **The owner must also inspect all mounts and brackets for cracks or other signs of fatigue every 3,000 miles.** Failure to do so could result in loss of the towed vehicle.
- **The owner must check the vehicle manufacturer's instructions for the proper procedure(s) to prepare the vehicle for towing.** Some vehicles must be equipped with a transmission lube pump, an axle disconnect, driveline disconnect or free-wheeling hubs before they can be towed. Failure to properly equip the vehicle will cause severe damage to the transmission.
- **If running changes were made** by the vehicle manufacturer after this bracket was designed, some bolts or other fasteners in the hardware pack may no longer be the correct size. **It is the installer's responsibility** to verify that the bracket is securely fastened to the vehicle and fitted with the correct hardware to account for these changes. Failure to securely fasten the bracket could result in loss of the towed vehicle.
- If the towed vehicle has been in an accident, it must be properly repaired before attaching the bracket. **Do not install the bracket if any structural frame damage is found.** Failure to repair the damage could result in the loss of the towed vehicle.
- Roadmaster manufactures many styles of brackets. **If your bracket has removable arms, they must be removed before driving the vehicle, unless the arms can be pinned or padlocked in place.** If not secured, the arms could vibrate out, resulting in non-warranty damage or personal injury.
- Some motorhome chassis have such a tight turning radius that you can damage your motorhome, towed vehicle, tow bar or bracket while turning sharply. **Before getting on the road, test your turning radius in an empty parking lot.** Turning too sharply could result in non-warranty damage to towing system, motorhome and/or towed vehicle.
- **Do not back up with the towed vehicle attached** or non-warranty damage will occur to your towing system, motorhome and/or towed vehicle.
- **The safety cables must connect the towing vehicle to the towed vehicle frame to frame, with the cables crossed, with enough slack for sharp turns.** Refer to the cable instructions for proper routing. Failure to leave enough slack in the safety cables, or failure to connect the safety cables frame to frame, will result in the loss of the towed vehicle.
- This bracket is designed for use with ROADMASTER tow bars and ROADMASTER adaptors only. **Using this bracket with other brands, without an approved ROADMASTER adaptor, may result in non-warranty damage or injury.**
- **Do not use this document for custom fabrication,** as it may not show all parts or structural components. Custom fabrication or an attempt to copy this bracket design could result in loss of the towed vehicle.
- Upon final installation, **the installer must inspect the bracket to ensure adequate clearance, particularly around hoses, air conditioner lines, radiators, etc.,** or non-warranty damage to the towed vehicle will result.
- **This bracket is only warranted for the original installation.** Installing a used bracket on another vehicle is not recommended and will void the warranty.



MOUNTING BRACKET KIT INSTALLATION INSTRUCTIONS

KIT# 521190-1

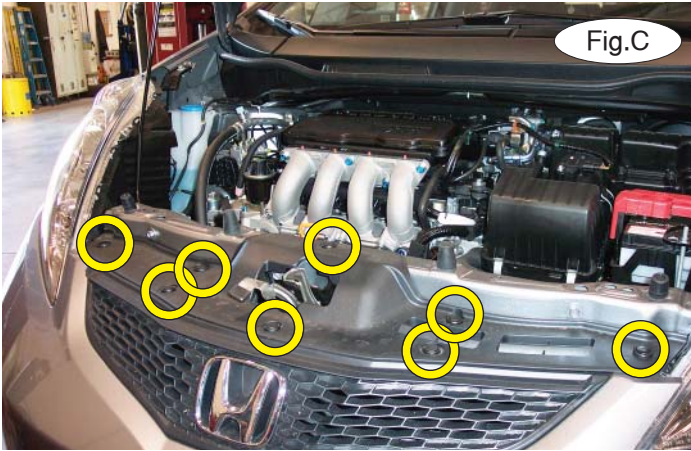

1. **Important:** please use all supplied bolts and parts and read all instructions carefully before beginning this installation. The majority of questions you may have can be answered within the text, and proper installation will ensure safe and secure travel. Now, begin the installation. Remove five plastic fasteners attaching the top of the fascia to the core support (Fig.C).



2. On each side, remove a Phillips head screw attaching the corner of the fascia to the fender. Then, in the same corner, if the fender liner is equipped with trim, press the blade of a sharp razor knife on the seam of the fascia and push straight through the trim to cut it in half (Fig.D).

3. Remove five plastic fasteners and four Phillips head screws attaching the bottom of the fascia to the splash shield (Fig.E).

4. Disconnect the fog lights, if the vehicle is so equipped. Pull out and forward to remove the fascia (Fig.F). *Note:* due to manufacturing variances, you may need a screwdriver to pop the fascia off its locking strip beneath the headlight, as indicated on Figure F.

5. On each side, remove four 12mm (head) bolts attaching the bumper core to the end of the frame rail.

Note: only three bolts are shown in Figure G. The fourth is to the inside of the bumper core.

Note: the bumper core will not be replaced. Retain the bumper core and attachment hardware so that it can be replaced if the bracket is ever removed.

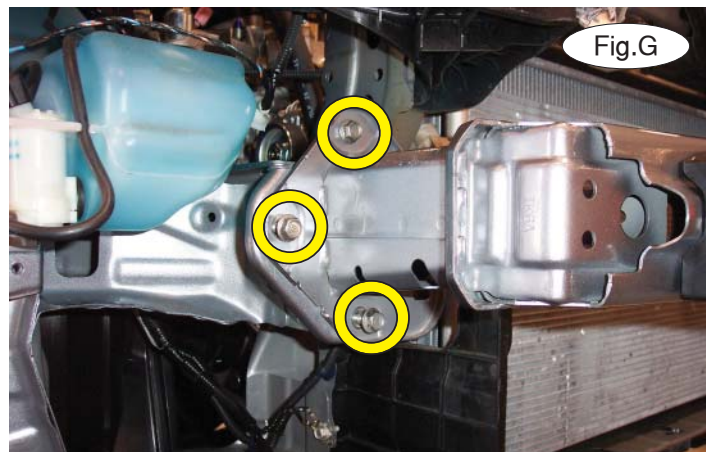



MOUNTING BRACKET KIT INSTALLATION INSTRUCTIONS

KIT# 521190-1

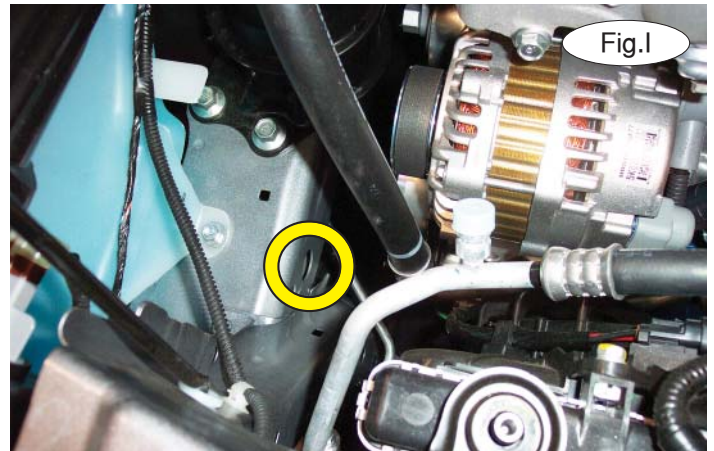
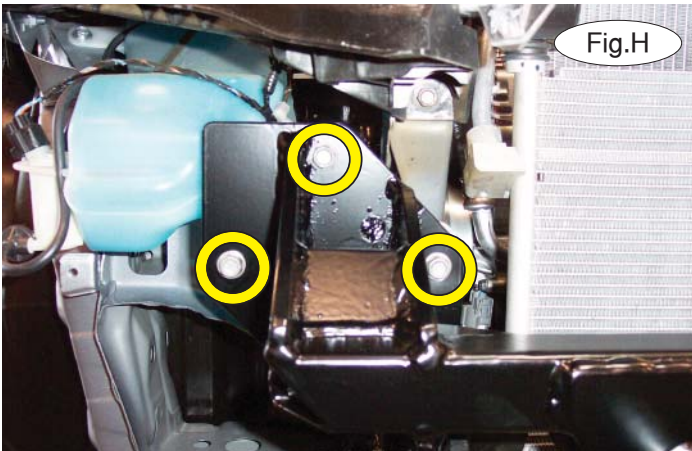

6. Place the main receiver brace over the ends of the frame rails. On each side, replace the four bolts removed in the previous step. *Note:* Figure H only shows three bolts. The fourth is below the brace.

Note: use thread lock on the bolts. Torque the bolts to the bolt torque requirements found at the end of this document.

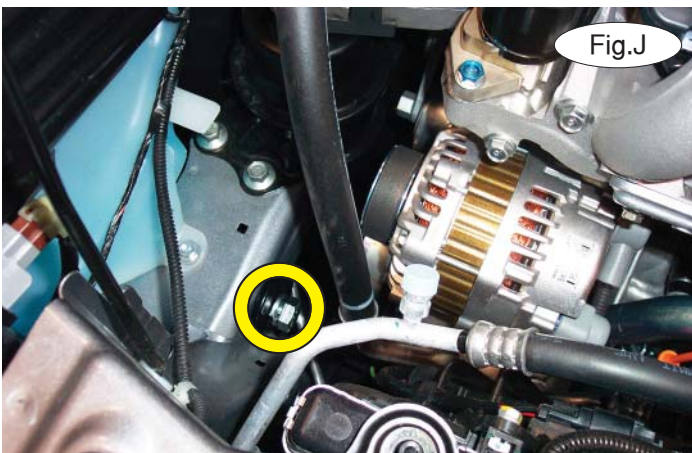

7. Locate the existing hole on the inside edge of the frame rail on each side (Fig.I – passenger side). Place a 1/2" lock washer and 1/2" clipped plate washer over one of the 1/2" x 1 3/4" bolts. Bolt through the existing hole on the inside edge of the frame rail and into the rear mounting point of the main receiver brace (Fig.J – passenger side).

8. Reassemble the fascia, reversing steps 1 through 4.

9. **For Sport models only:** trim the fascia using the red lines in Figure K as a guide for trimming. Figure L shows the completed trimming. **For all other models:** proceed to step 10.





MOUNTING BRACKET KIT INSTALLATION INSTRUCTIONS

KIT# 521190-1

10. Insert the removable front bracket arms into the front receiver braces, and twist each one 90 degrees to lock.
11. Attach the 8" safety cables with the cable connectors (Q-Links) to the front of the receiver braces (Fig.M).
12. Attach the ends of the safety cables to the tow vehicle's safety cables.
13. Install the tow bar to the mounting bracket according to the manufacturer's instructions.

Note: if the bracket is so equipped, the holes in the alignment tabs which are welded to the arms and main receiver braces are for padlocks only. Under no circumstances should you bolt the alignment tabs together. Bolting the alignment tabs together may result in non-warranty damage to the bracket.



BOLT TORQUE REQUIREMENTS

Note: The torque values represented below are intended as general guidelines. Torque requirements for specific applications may vary. Roadmaster does not warrant this information to be accurate for all applications and disclaims all liability for any claims or damages which may result from its use.

STANDARD BOLTS

Thread Size	Grade	Torque
5/16.....	5.....	13 ft./lb.
3/8.....	5.....	23 ft./lb.
7/16.....	5.....	37 ft./lb.
1/2.....	5.....	56 ft./lb.
5/8.....	5.....	150 ft./lb.

METRIC BOLTS

Thread Size	Grade	Plated / Unplated
8mm-1.0	8.8	20 ft./lb. 18 ft./lb.
8mm-1.25	8.8	19 ft./lb. 18 ft./lb.
10mm-1.25	8.8	38 ft./lb. 36 ft./lb.
10mm-1.5	8.8	37 ft./lb. 35 ft./lb.

METRIC BOLTS

Thread Size	Grade	Plated / Unplated
12mm-1.25	8.8	70 ft./lb. 65 ft./lb.
12mm-1.5	8.8	66 ft./lb. 61 ft./lb.
12mm-1.75	8.8	65 ft./lb. 60 ft./lb.
14mm-2.0	8.8	104 ft./lb. 97 ft./lb.

All illustrations and specifications contained herein are based on the latest information available at the time of publication approval. ROADMASTER, INC. reserves the right to make changes at any time without notice in material, specification and models or to discontinue models.