

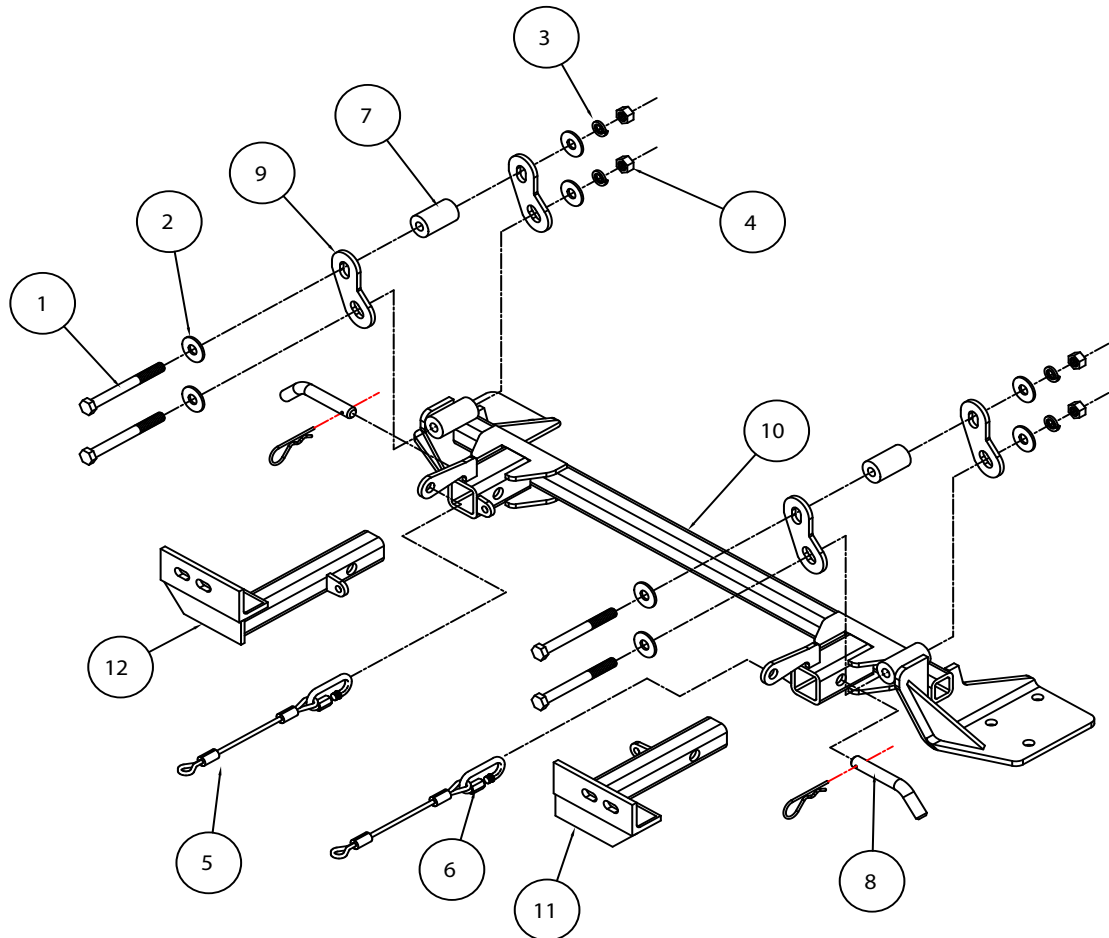

MOUNTING BRACKET KIT INSTALLATION INSTRUCTIONS

KIT# 3116-1



ITEM	QTY	NAME	PART #
1	4	1/2" x 4" BOLT	350105-00
2	8	1/2" FLAT WASHER	350308-00
3	4	1/2" LOCK WASHER	350309-00
4	4	1/2" NUT	350258-00
5	2	8" SAFETY CABLE	500646-08
6	2	QUICK LINK	200008-00
7	2	1 1/4" x 2 1/8" SPACER	A-000606
8	2	DRAW PIN/SPRING PIN	357035-00
9	4	1/4" x 2 3/4" x 4 3/16" BACKING PLATE	A-000959
10	1	MAIN RECEIVER	C-000552
11	1	DRIVER SIDE ARM	C-000553A
12	1	PASSENGER SIDE ARM	C-000554A



MOUNTING BRACKET KIT INSTALLATION INSTRUCTIONS

KIT# 3116-1

This bracket kit is one of our XL series, which is designed to be partly removable.

The kit consists of the main receiver brace, side braces, lower braces, front braces and a hardware pack.

The main receiver brace bolts to the side braces, which are bolted inside the frame tubes on each side. The lower braces connect the main receiver brace to the lower sub frame mounts under the radiator cross member. The front braces insert into the receivers on each side.

Start by laying the kit out according to the illustration. This will give you a visual idea of how the kit installs and also confirm that the kit components are present and accounted for.



IMPORTANT: All brackets **must** be assembled with all the bolts left loose for final adjustment and positioning (before tightening) unless otherwise instructed. All bolts **must** be torqued for proper strength. If more than one bolt is used per fastening point, the diagram may only show one.

- Use flat washers over all slotted holes
- Use lock washers on all fasteners

ROADMASTER Limited Warranty, including One-Year Conditional Warranty Text and Product Registration Card, in Carton.

WARNING

Failure to follow these instructions can result in property damage, personal injury or even death.

- **Installation of most mounting brackets requires moderate mechanical aptitude and skills.** We strongly recommend professional installation by an experienced installer.
- **The installer must read the instructions and use all bolts and parts supplied.** Failure to do so could result in loss of the towed vehicle.
- **Use Loctite® Red** on all bolts used for mounting this bracket.
- **Every 3,000 miles, the owner must inspect the fasteners** for proper torque, according to the bolt torque requirements chart on the last page of these instructions. **The owner must also inspect all mounts and brackets for cracks or other signs of fatigue every 3,000 miles.** Failure to do so could result in loss of the towed vehicle.
- **The owner must check the vehicle manufacturer's instructions for the proper procedure(s) to prepare the vehicle for towing.** Some vehicles must be equipped with a transmission lube pump, an axle disconnect, driveline disconnect or free-wheeling hubs before they can be towed. Failure to properly equip the vehicle will cause severe damage to the transmission.
- **If running changes were made** by the vehicle manufacturer after this bracket was designed, some bolts or other fasteners in the hardware pack may no longer be the correct size. **It is the installer's responsibility** to verify that the bracket is securely fastened to the vehicle and fitted with the correct hardware to account for these changes. Failure to securely fasten the bracket could result in loss of the towed vehicle.
- If the towed vehicle has been in an accident, it must be properly repaired before attaching the bracket. **Do not install the bracket if any structural frame damage is found.** Failure to repair the damage could result in the loss of the towed vehicle.
- Roadmaster manufactures many styles of brackets. **If your bracket has removable arms, they must be removed before driving the vehicle, unless the arms can be pinned or padlocked in place.** If not secured, the arms could vibrate out, resulting in non-warranty damage or personal injury.
- Some motorhome chassis have such a tight turning radius that you can damage your motorhome, towed vehicle, tow bar or bracket while turning sharply. **Before getting on the road, test your turning radius in an empty parking lot.** Turning too sharply could result in non-warranty damage to towing system, motorhome and/or towed vehicle.
- **Do not back up with the towed vehicle attached** or non-warranty damage will occur to your towing system, motorhome and/or towed vehicle.
- **The safety cables must connect the towing vehicle to the towed vehicle frame to frame, with the cables crossed, with enough slack for sharp turns.** Refer to the cable instructions for proper routing. Failure to leave enough slack in the safety cables, or failure to connect the safety cables frame to frame, will result in the loss of the towed vehicle.
- This bracket is designed for use with ROADMASTER tow bars and ROADMASTER adaptors only. **Using this bracket with other brands, without an approved ROADMASTER adaptor, may result in non-warranty damage or injury.**
- **Do not use this document for custom fabrication,** as it may not show all parts or structural components. Custom fabrication or an attempt to copy this bracket design could result in loss of the towed vehicle.
- Upon final installation, **the installer must inspect the bracket to ensure adequate clearance, particularly around hoses, air conditioner lines, radiators, etc.,** or non-warranty damage to the towed vehicle will result.
- **This bracket is only warranted for the original installation.** Installing a used bracket on another vehicle is not recommended and will void the warranty.



MOUNTING BRACKET KIT INSTALLATION INSTRUCTIONS

KIT# 3116-1



1. **Important: please use all supplied bolts and parts and read all instructions carefully before beginning this installation. The majority of questions you may have can be answered within the text, and proper installation will ensure safe and secure travel. Now, begin the installation.** Starting at the top of the fascia, remove seven plastic fasteners from the top grill cover (Fig.A).

2. Remove the headlights by removing two 13mm (head) bolts in each light (Fig.B). Set the lights aside for now (Fig.C).

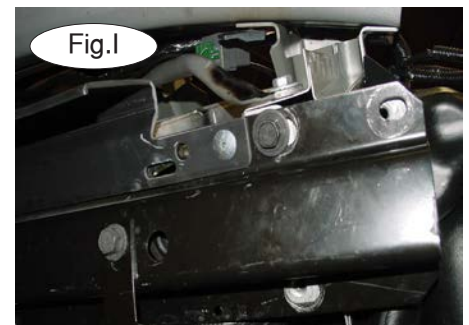
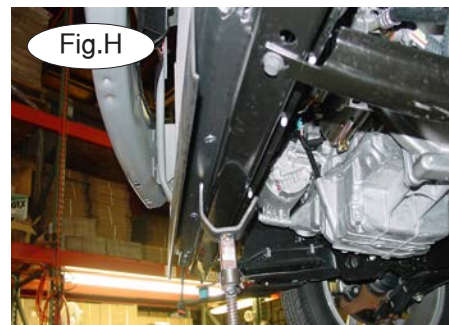
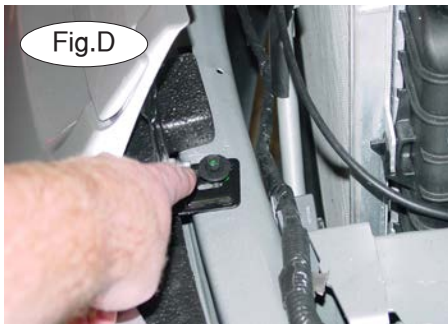

3. Remove one 10mm (head) screw from the top of the bumper core on each side (Fig.D).

4. Move to the inside of the fender wells and remove a 10mm (head) screw then loosen the remaining two screws on each side (Fig.E).

5. Pull forward on the fascia to remove (Fig.F). Disconnect the marker lights then set aside (Fig.G).

6. Before proceeding, support or secure the lower radiator to the frame so that it can't drop when the lower support bolts are removed (Fig.H).

7. Now, remove three 13mm (head) bolts on each side of the frame (Fig.I,J).

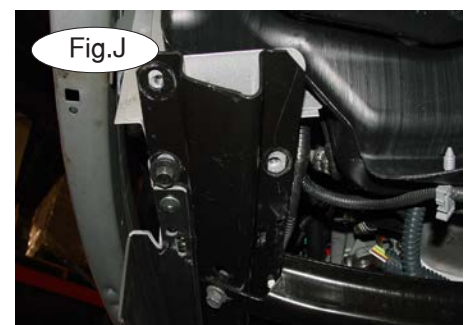



MOUNTING BRACKET KIT INSTALLATION INSTRUCTIONS

KIT# 3116-1

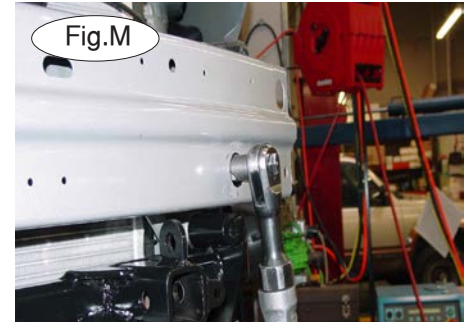
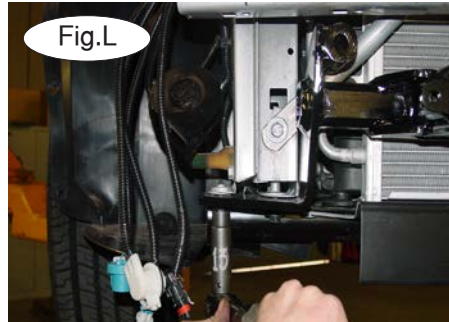
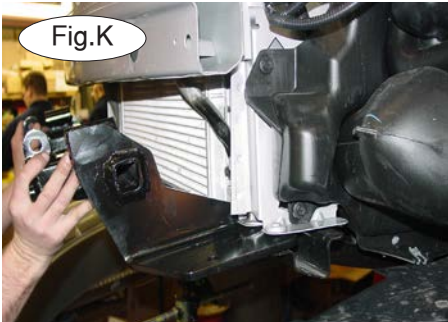

8. Lower the radiator support enough to slip the receiver braces rear mounts between the frame and the radiator support (Fig.K). *Note:* don't let the radiator support drop too far.

9. Bolt in place with the existing bolts removed in step 7 and tighten to hold (Fig.L).

10. Find the lower bumper core stud on each side and remove the nuts. Now, knock them out the back of the frame with a large punch (Fig.M,N,O).

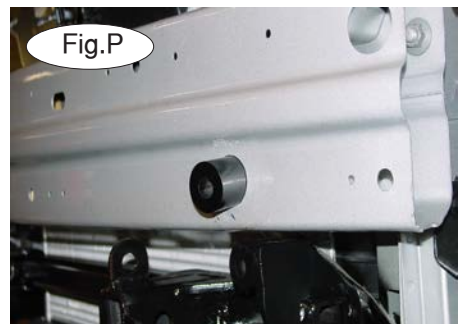
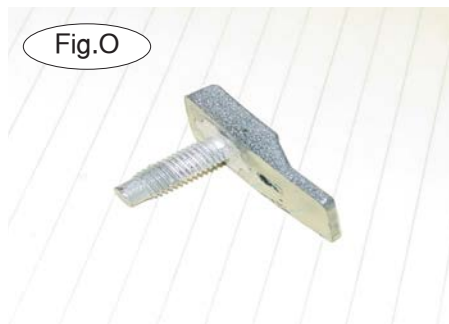

11. Insert two 1/8" pipe spacers in the large bumper core holes and bolt through the spacers, upper brace plates and frame with 1/2" x 4" bolts, flat washers, lock washers and nuts (Fig.P,Q,R).



12. Torque all mounting bolts to the specifications at the end of these instructions.

13. Trim the bumper core foam, as needed, to fit around the braces (Fig.S). Refit the core (Fig.T).

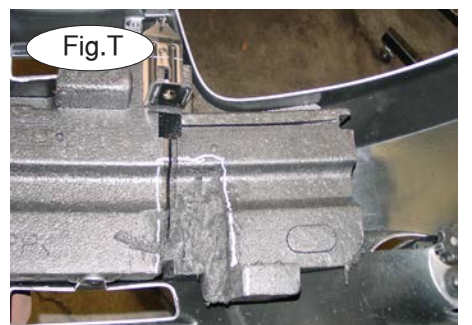



MOUNTING BRACKET KIT INSTALLATION INSTRUCTIONS

KIT# 3116-1

- 14. Reverse steps 1 through 5 to refit the the fascia.
- 15. Install the front braces and secure with 5/8" draw pins and 3/16" spring pins (Fig.U).
- 16. Install the safety cables and connectors.
- 17. Install the tow bar according to the manufacturer's instructions.
- 18. Attach the ends of the 8" safety cables to the front holes on each side of the receiver brace. Connect the other end to the tow vehicle's safety cables and tow bar.



BOLT TORQUE REQUIREMENTS

Note: The torque values represented below are intended as general guidelines. Torque requirements for specific applications may vary. Roadmaster does not warrant this information to be accurate for all applications and disclaims all liability for any claims or damages which may result from its use.

STANDARD BOLTS

Thread Size	Grade	Torque
5/16.....	5.....	13 ft./lb.
3/8.....	5.....	23 ft./lb.
7/16.....	5.....	37 ft./lb.
1/2.....	5.....	56 ft./lb.
5/8.....	5.....	150 ft./lb.

METRIC BOLTS

Thread Size	Grade	Plated / Unplated
8mm-1.0	8.8	20 ft./lb. 18 ft./lb.
8mm-1.25	8.8	19 ft./lb. 18 ft./lb.
10mm-1.25	8.8	38 ft./lb. 36 ft./lb.
10mm-1.5	8.8	37 ft./lb. 35 ft./lb.

METRIC BOLTS

Thread Size	Grade	Plated / Unplated
12mm-1.25	8.8	70 ft./lb. 65 ft./lb.
12mm-1.5	8.8	66 ft./lb. 61 ft./lb.
12mm-1.75	8.8	65 ft./lb. 60 ft./lb.
14mm-2.0	8.8	104 ft./lb. 97 ft./lb.