



# MOUNTING BRACKET KIT INSTALLATION INSTRUCTIONS

**KIT# 3115-3**

**Important**

*Note: this bracket will not accommodate the Guardian rock shield, some models of the Tow Defender, Stowaway or the StowMaster and StowMaster All Terrain tow bars.*

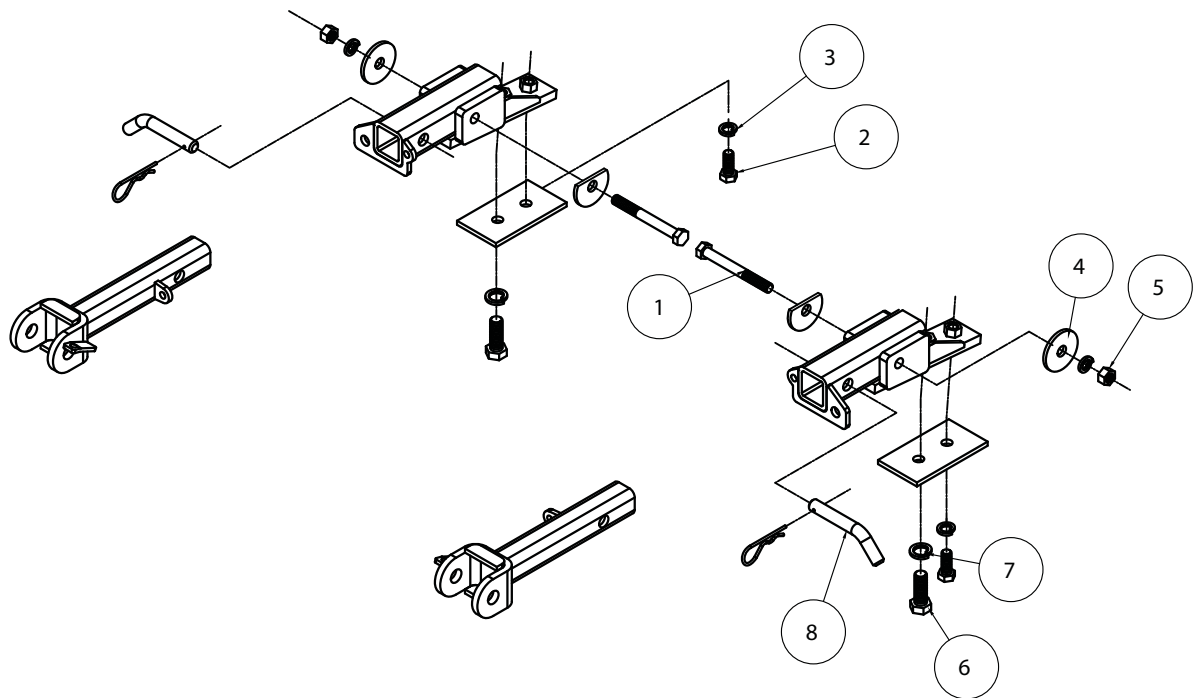

Item	Qty.	Length	Width	Description	Part #
1.....	2 .....	5" .....	5/8" .....	5/8" x 5" BOLT .....	350160-00
2.....	2 .....	1 3/4" .....	1/2" .....	1/2" x 1 3/4" BOLT .....	350096-00
3.....	2 .....	.....	1/2" .....	LOCK WASHER .....	350309-00
4.....	2 .....	.....	2 1/2" .....	5/8" PLATE WASHER .....	350352-00
5.....	2 .....	.....	5/8" .....	NUT .....	350262-00
6.....	2 .....	1 3/4" .....	5/8" .....	BOLT.....	350149-00
7.....	4 .....	.....	5/8" .....	LOCK WASHER .....	350313-00
8.....	2 .....	.....	.....	DRAW PIN / SPRING PIN.....	357035-00



# MOUNTING BRACKET KIT INSTALLATION INSTRUCTIONS

**KIT# 3115-3**

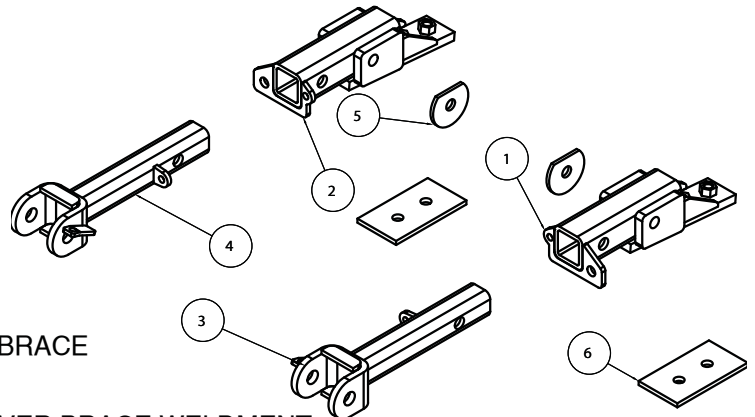

Item	Qty.	Part #	Description
1.....	1	C-000526.....	DRIVER SIDE RECEIVER BRACE WELDMENT
2.....	1	C-000527.....	PASSENGER SIDE RECEIVER BRACE WELDMENT
3.....	1	C-000557.....	DRIVER SIDE ARM WELDMENT
4.....	1	C-000558.....	PASSENGER SIDE ARM WELDMENT
5.....	2	A-001763.....	5/8" CLIPPED PLATE WASHER
6.....	2	A-001995.....	1/4" X 2 3/4" X 5" PLATE

**IMPORTANT:** All brackets **must** be assembled with all the bolts left loose for final adjustment and positioning (before tightening) unless otherwise instructed. All bolts **must** be torqued for proper strength. If more than one bolt is used per fastening point, the diagram may only show one.

- Use flat washers over all slotted holes
- Use lock washers on all fasteners

ROADMASTER Limited Warranty, including One-Year Conditional Warranty Text and Product Registration Card, in Carton.

## WARNING

Failure to follow these instructions can result in property damage, personal injury or even death.

- Installation of most mounting brackets requires moderate mechanical aptitude and skills. We strongly recommend professional installation by an experienced installer.
- The installer must read the instructions and use all bolts and parts supplied. Failure to do so could result in loss of the towed vehicle.
- Use Loctite® Red on all bolts used for mounting this bracket.
- Every 3,000 miles, the owner must inspect the fasteners for proper torque, according to the bolt torque requirements chart on the last page of these instructions. The owner must also inspect all mounts and brackets for cracks or other signs of fatigue every 3,000 miles. Failure to do so could result in loss of the towed vehicle.
- The owner must check the vehicle manufacturer's instructions for the proper procedure(s) to prepare the vehicle for towing. Some vehicles must be equipped with a transmission lube pump, an axle disconnect, driveline disconnect or free-wheeling hubs before they can be towed. Failure to properly equip the vehicle will cause severe damage to the transmission.
- If running changes were made by the vehicle manufacturer after this bracket was designed, some bolts or other fasteners in the hardware pack may no longer be the correct size. It is the installer's responsibility to verify that the bracket is securely fastened to the vehicle and fitted with the correct hardware to account for these changes. Failure to securely fasten the bracket could result in loss of the towed vehicle.
- If the towed vehicle has been in an accident, it must be properly repaired before attaching the bracket. Do not install the bracket if any structural frame damage is found. Failure to repair the damage could result in the loss of the towed vehicle.
- Roadmaster manufactures many styles of brackets. If your bracket has removable arms, they must be removed before driving the vehicle, unless the arms can be pinned or padlocked in place. If not secured, the arms could vibrate out, resulting in non-warranty damage or personal injury.
- Some motorhome chassis have such a tight turning radius that you can damage your motorhome, towed vehicle, tow bar or bracket while turning sharply. Before getting on the road, test your turning radius in an empty parking lot. Turning too sharply could result in non-warranty damage to towing system, motorhome and/or towed vehicle.
- Do not back up with the towed vehicle attached or non-warranty damage will occur to your towing system, motorhome and/or towed vehicle.
- The safety cables must connect the towing vehicle to the towed vehicle frame to frame, with the cables crossed, with enough slack for sharp turns. Refer to the cable instructions for proper routing. Failure to leave enough slack in the safety cables, or failure to connect the safety cables frame to frame, will result in the loss of the towed vehicle.
- This bracket is designed for use with ROADMASTER tow bars and ROADMASTER adaptors only. Using this bracket with other brands, without an approved ROADMASTER adaptor, may result in non-warranty damage or injury.
- Do not use this document for custom fabrication, as it may not show all parts or structural components. Custom fabrication or an attempt to copy this bracket design could result in loss of the towed vehicle.
- Upon final installation, the installer must inspect the bracket to ensure adequate clearance, particularly around hoses, air conditioner lines, radiators, etc., or non-warranty damage to the towed vehicle will result.
- This bracket is only warranted for the original installation. Installing a used bracket on another vehicle is not recommended and will void the warranty.



# MOUNTING BRACKET KIT INSTALLATION INSTRUCTIONS

**KIT# 3115-3**

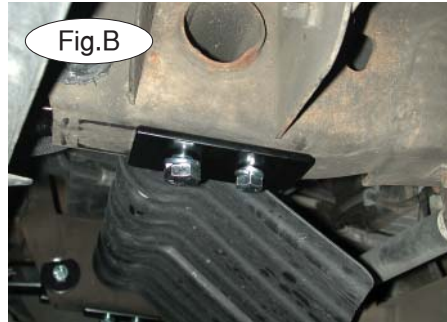
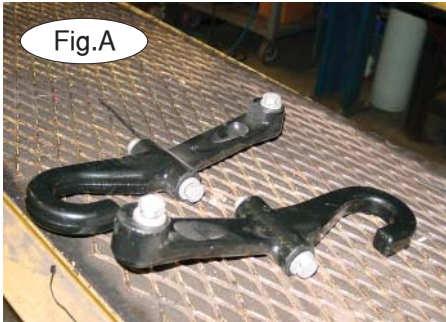

This bracket kit is one of our MX series, which allows the visible front portion of the brackets to be easily removed from the front of the vehicle. The kit consists of two receiver braces, two front braces and a hardware pack. The main receiver braces mount in the front of the frame tubes to the same mounting points as the factory tow hooks. The tow hooks are removed and replaced with the receiver braces. The front braces insert into the receivers on each side.

Before starting the installation, lay out the kit components in order, as they will be used. This will give you a visual idea of how the components work, and will also confirm that everything is present and accounted for.

**Note: for the 2007-2013 Chevrolet Suburban 2500 and 2007 GMC Yukon 2500, follow the supplemental instructions on the next page for step 1.**

1. **Important: please use all supplied bolts and parts and read all instructions carefully before beginning this installation. The majority of questions you may have can be answered within the text, and proper installation will ensure safe and secure travel.** Now, begin the installation by removing the front stock tow hooks (three bolts) on each side (Fig.B).

2. Insert the receiver braces in the front of the frame tubes on each side over the tow hook mounting holes.

3. Working on one side at a time, bolt the receiver braces in place, using a 1/2" x 1 3/4" bolt, lock washer and 1/4" x 2 3/4" x 5" backing plate (holes are 21/32" and 9/16") in the bottom rear mounting hole and a 5/8" x 1 3/4" bolt and lock washer in the front bottom mounting hole (Fig.C). Leave the bottom bolts loose for the next step.

4. Using a 5/8" drill bit or die grinder, enlarge the existing holes in the frame to 5/8" (Fig.D).

5. Bolt through the holes with the 5/8" x 5" bolt, plate washer, lock washer and nut (Fig.E). *Note: the cut plate washer goes to the inside of the frame, on both sides.*

6. Repeat steps 4 and 5 for the remaining side then torque all mounting bolts to the specifications at the bottom of these instructions.

7. Fit the front bracket arms into the front receiver braces, and secure them in place with the supplied 5/8" draw pins and spring pins. *Note: for the 2007-2013 Chevrolet Suburban 2500 and 2007 GMC Yukon 2500, the draw pins install from underneath the fascia.*

8. Install the tow bar to the mounting bracket according to the manufacturer's instructions. Attach the safety cables to the main receiver brace.

## BOLT TORQUE REQUIREMENTS

Note: The torque values represented below are intended as general guidelines. Torque requirements for specific applications may vary. Roadmaster does not warrant this information to be accurate for all applications and disclaims all liability for any claims or damages which may result from its use.

### STANDARD BOLTS

Thread Size	Grade	Torque
5/16	5	13 ft./lb.
3/8	5	23 ft./lb.
7/16	5	37 ft./lb.
1/2	5	56 ft./lb.
5/8	5	150 ft./lb.

### METRIC BOLTS

Thread Size	Grade	Plated / Unplated
8mm-1.0	8.8	20 ft./lb. 18 ft./lb.
8mm-1.25	8.8	19 ft./lb. 18 ft./lb.
10mm-1.25	8.8	38 ft./lb. 36 ft./lb.
10mm-1.5	8.8	37 ft./lb. 35 ft./lb.

### METRIC BOLTS

Thread Size	Grade	Plated / Unplated
12mm-1.25	8.8	70 ft./lb. 65 ft./lb.
12mm-1.5	8.8	66 ft./lb. 61 ft./lb.
12mm-1.75	8.8	65 ft./lb. 60 ft./lb.
14mm-2.0	8.8	104 ft./lb. 97 ft./lb.



# **MOUNTING BRACKET KIT INSTALLATION INSTRUCTIONS**

**KIT# 3115-3**

## **2007-2013 Chevrolet Suburban 2500 and 2007 GMC Yukon 2500 Supplemental Instructions**

1. Start by removing the front stock tow hooks (two bolts) on each side.
2. Now, trim the tow hook plastic inserts (Fig.A, B), using the yellow marker line as a guide for correct trimming.
3. For 2007 GMC Yukon 2500 models, trim the grille insert to allow clearance for the receivers.
4. Refer back to step 2 on the previous page to finish this installation.

