



MOUNTING BRACKET KIT INSTALLATION INSTRUCTIONS

KIT# 1555-3

Important

Note: this bracket will not accommodate the Guardian rock shield, some models of the Tow Defender, Stowaway or the StowMaster and StowMaster All Terrain tow bars.

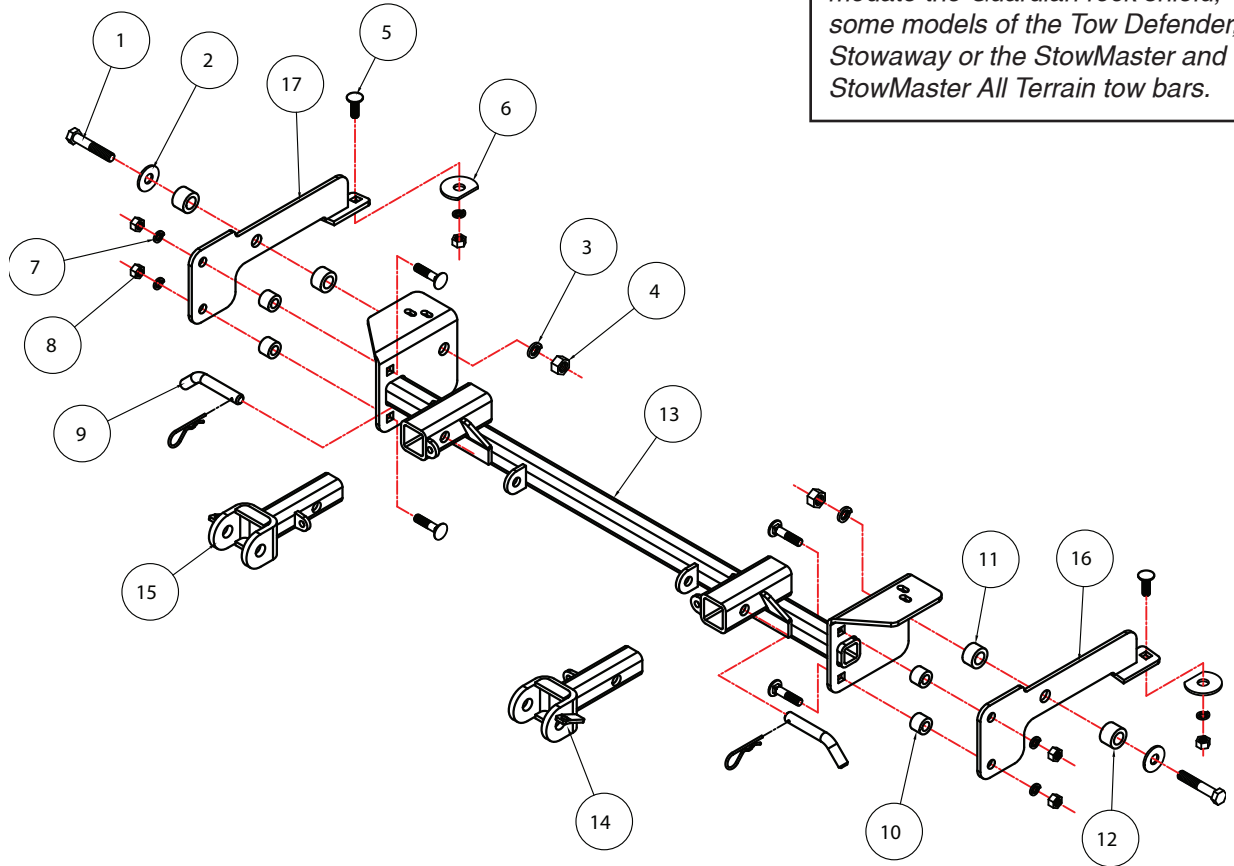

Item	Qty.	Description	Part No.
1.....	2.....	5/8" x 3 1/2" BOLT.....	350163-00
2.....	2.....	5/8" FLAT WASHER.....	350312-00
3.....	2.....	5/8" LOCK WASHER.....	350313-00
4.....	2.....	5/8" NUT.....	350262-00
5.....	6.....	1/2" x 2" BOLT.....	350373-00
6.....	2.....	1/2" CLIPPED PLATE WASHER.....	A-002687
7.....	6.....	1/2" LOCK WASHER.....	350309-00
8.....	6.....	1/2" NUT.....	350258-00
9.....	2.....	DRAW PIN / SPRING PIN.....	357035-00
10.....	4.....	1" ROUND x 3/4" x .219 WALL TUBE.....	A-000558
11.....	2.....	1 1/4" ROUND x 3/4" x .250 WALL TUBE.....	A-000559
12.....	2.....	1 1/4" ROUND x 7/8" x .250 WALL TUBE.....	A-000481
13.....	1.....	MAIN RECEIVER.....	C-001080
14.....	1.....	DRIVER SIDE ARM.....	C-001083
15.....	1.....	PASSENGER SIDE ARM.....	C-001084
16.....	1.....	DRIVER SIDE BRACE.....	C-000295
17.....	1.....	PASSENGER SIDE BRACE.....	C-000296
18.....	2.....	ZIP TIES.....	300140-00



MOUNTING BRACKET KIT INSTALLATION INSTRUCTIONS

KIT# 1555-3

This is one of our MX series brackets, which is hidden, for the most part, behind the front bumper fascia and the grille (Fig.A). The kit consists of the main receiver brace, front braces, rear side braces and a hardware pack. The main receiver brace replaces the bumper core behind the front bumper fascia, and mounts to the front frame and radiator support area on each side.

Before starting the installation, lay out the kit components in order, starting with step 2. This will give you a visual idea of how the components work and will also confirm that everything is present and accounted for.



IMPORTANT: All brackets **must** be assembled with all the bolts left loose for final adjustment and positioning (before tightening) unless otherwise instructed. All bolts **must** be torqued for proper strength. If more than one bolt is used per fastening point, the diagram may only show one.

- Use flat washers over all slotted holes
- Use lock washers on all fasteners

ROADMASTER Limited Warranty, including One-Year Conditional Warranty Text and Product Registration Card, in Carton.

WARNING

Failure to follow these instructions can result in property damage, personal injury or even death.

- Installation of most mounting brackets requires moderate mechanical aptitude and skills. We strongly recommend professional installation by an experienced installer.
- The installer must read the instructions and use all bolts and parts supplied. Failure to do so could result in loss of the towed vehicle.
- Use Loctite® Red on all bolts used for mounting this bracket.
- Every 3,000 miles, the owner must inspect the fasteners for proper torque, according to the bolt torque requirements chart on the last page of these instructions. The owner must also inspect all mounts and brackets for cracks or other signs of fatigue every 3,000 miles. Failure to do so could result in loss of the towed vehicle.
- The owner must check the vehicle manufacturer's instructions for the proper procedure(s) to prepare the vehicle for towing. Some vehicles must be equipped with a transmission lube pump, an axle disconnect, driveline disconnect or free-wheeling hubs before they can be towed. Failure to properly equip the vehicle will cause severe damage to the transmission.
- If running changes were made by the vehicle manufacturer after this bracket was designed, some bolts or other fasteners in the hardware pack may no longer be the correct size. It is the installer's responsibility to verify that the bracket is securely fastened to the vehicle and fitted with the correct hardware to account for these changes. Failure to securely fasten the bracket could result in loss of the towed vehicle.
- If the towed vehicle has been in an accident, it must be properly repaired before attaching the bracket. Do not install the bracket if any structural frame damage is found. Failure to repair the damage could result in the loss of the towed vehicle.
- Roadmaster manufactures many styles of brackets. If your bracket has removable arms, they must be removed before driving the vehicle, unless the arms can be pinned or padlocked in place. If not secured, the arms could vibrate out, resulting in non-warranty damage or personal injury.
- Some motorhome chassis have such a tight turning radius that you can damage your motorhome, towed vehicle, tow bar or bracket while turning sharply. Before getting on the road, test your turning radius in an empty parking lot. Turning too sharply could result in non-warranty damage to towing system, motorhome and/or towed vehicle.
- Do not back up with the towed vehicle attached or non-warranty damage will occur to your towing system, motorhome and/or towed vehicle.
- The safety cables must connect the towing vehicle to the towed vehicle frame to frame, with the cables crossed, with enough slack for sharp turns. Refer to the cable instructions for proper routing. Failure to leave enough slack in the safety cables, or failure to connect the safety cables frame to frame, will result in the loss of the towed vehicle.
- This bracket is designed for use with ROADMASTER tow bars and ROADMASTER adaptors only. Using this bracket with other brands, without an approved ROADMASTER adaptor, may result in non-warranty damage or injury.
- Do not use this document for custom fabrication, as it may not show all parts or structural components. Custom fabrication or an attempt to copy this bracket design could result in loss of the towed vehicle.
- Upon final installation, the installer must inspect the bracket to ensure adequate clearance, particularly around hoses, air conditioner lines, radiators, etc., or non-warranty damage to the towed vehicle will result.
- This bracket is only warranted for the original installation. Installing a used bracket on another vehicle is not recommended and will void the warranty.



MOUNTING BRACKET KIT INSTALLATION INSTRUCTIONS

KIT# 1555-3

1. **Important:** please use all supplied bolts and parts and read all instructions carefully before beginning this installation. The majority of questions you may have can be answered within the text, and proper installation will ensure safe and secure travel. Now, begin the installation by removing the nine plastic fasteners on the top of the plastic grille cover (Fig.B).

2. Remove one 10mm bolt on the battery strap (Fig.C).
3. Remove the plastic radiator cover (Fig.B).
4. Remove one 8mm bolt (on each side), which is located at the outside corner of the fender well (Fig.D).

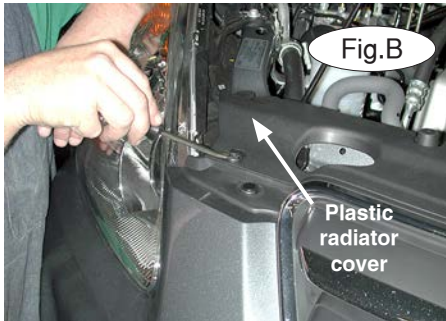

5. Remove one Phillips screw (on each side), at the bottom of the fender well (Fig.E).
6. Remove the 16 plastic fasteners from the splash shield (Fig.F), then remove the splash shield.
7. Unplug the fog lights, if the vehicle is so equipped (Fig.G).



8. Remove the fascia, by pulling forward from the edge of the fender well (Fig.H).

9. Remove the outside temperature sensor from the bumper core and use the two supplied zip ties to reattach the temperature sensor to the main brace, after installation (Fig.I).

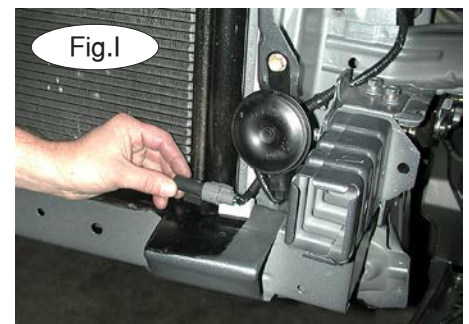



MOUNTING BRACKET KIT INSTALLATION INSTRUCTIONS

KIT# 1555-3

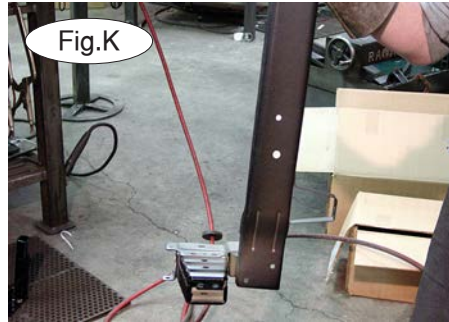
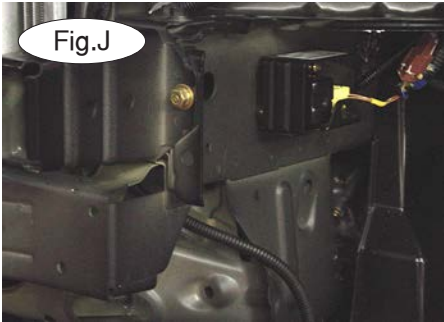

10. Now, find seven to eight 10mm head bolts – four or five on the passenger side, and three on the driver's side, which hold the steel bumper core and mounts. Remove all these bolts (Fig.J), then pull forward to remove the bumper core and the bumper core supports (Fig.K). The bumper core is replaced by the receiver brace and will not be reinstalled. *Note:* retain the bumper core and attachment hardware so that it can be replaced if the bracket is ever removed

11. Loosen the 10mm head bolt in each horn mount (Fig.L).

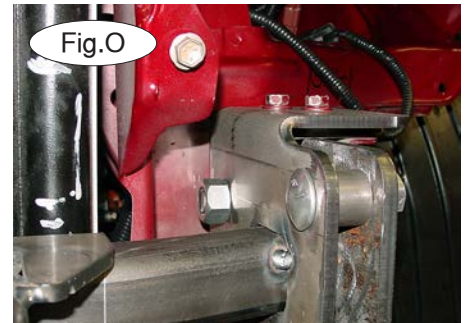
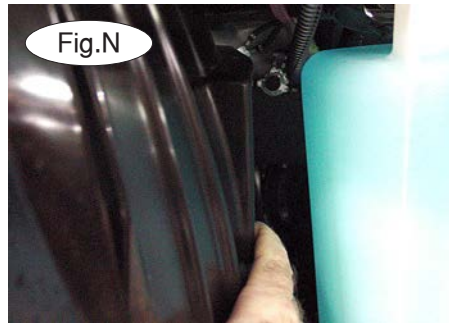

12. Working on the driver's side, put a 1/2" x 2" carriage bolt through the rear mounting hole in a rear side mounting brace. Insert this brace into the front of the formed frame tube, with the rear bolt through a corresponding hole in the bottom of the frame. Secure with a 1/2" nut, clipped plate washer, lock washer and nut (Fig.M). Leave loose at this time.

13. Repeat step 12 for the passenger side. *Note:* An additional fender well fastener can be removed, and the fender liner pushed back, to allow access to the rear mounting bolt on the passenger side (Fig.N).

14. Hold the main receiver brace between the frame tubes and bolt through the two top holes on each side with four of the bolts removed from the bumper core in step 10 (Fig.O). Leave loose at this time.

15. Using the existing frame side hole (Fig.P), start with a 5/8" x 3 1/2" bolt and 5/8" flat washer. Then, on the inside of the frame, use a 7/8" x 1 1/4" O.D. pipe spacer. Next, use a 3/4" x 1 1/4" pipe spacer, and then the lock washer and nut, as shown in Fig.Q. Repeat this process for the other side (Fig.P and Fig.Q).

16. Bolt through the two front holes on each side in the receiver brace and side braces with 1/2" x 2" carriage bolts, flat washers, 3/4" x 1" spacers, lock washers and nuts (Fig.P, Fig.Q and Fig.R).

17. Torque all bolts to the mounting specifications on the next page (Fig.R).

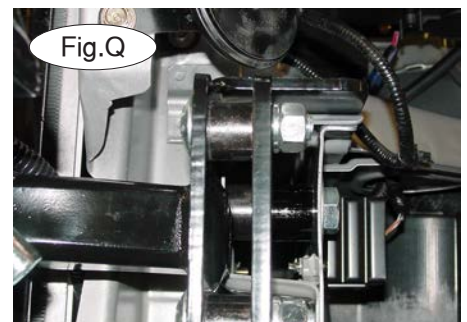
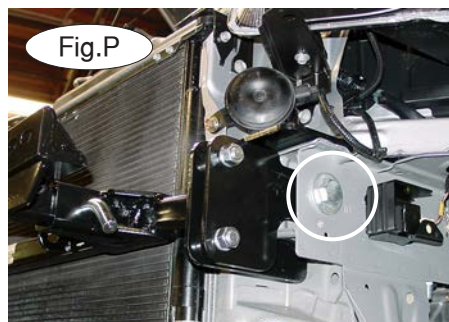



MOUNTING BRACKET KIT INSTALLATION INSTRUCTIONS

KIT# 1555-3

18. Tighten the horns loosened in step 11, bending or displacing the mounting to prevent the horns from touching any part of the vehicle or the brace. Note: Any contact with any object other than the horn mount will either alter or prevent sound output.

19. Reverse steps 1 through 8 to reinstall the bumper fascia and top cover.

20. To allow access for the draw pin, trim a small portion of the front grille (Fig.S), then insert the front braces into the receiver tubes. Pin them with 5/8" draw pins and spring pins.

21. Install the tow bar according to the manufacturer's instructions, and torque all mounting bolts to the specifications below.

22. Attach the safety cables to the main receiver brace.

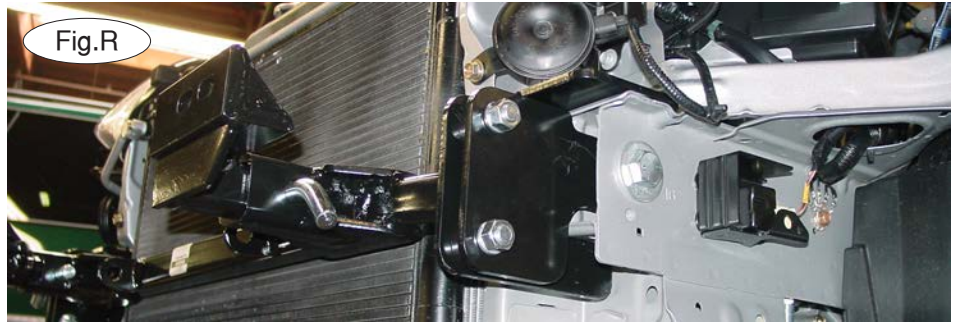

Fig.R

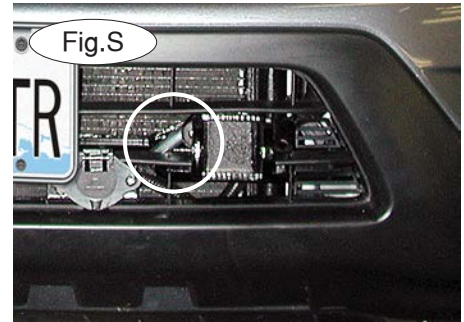

Fig.S

BOLT TORQUE REQUIREMENTS

Note: The torque values represented below are intended as general guidelines. Torque requirements for specific applications may vary. Roadmaster does not warrant this information to be accurate for all applications and disclaims all liability for any claims or damages which may result from its use.

STANDARD BOLTS

Thread Size	Grade	Torque
5/16.....	5.....	13 ft./lb.
3/8.....	5.....	23 ft./lb.
7/16.....	5.....	37 ft./lb.
1/2.....	5.....	56 ft./lb.
5/8.....	5.....	150 ft./lb.

METRIC BOLTS

Thread Size	Grade	Plated / Unplated
8mm-1.0	8.8	20 ft./lb. 18 ft./lb.
8mm-1.25	8.8	19 ft./lb. 18 ft./lb.
10mm-1.25	8.8	38 ft./lb. 36 ft./lb.
10mm-1.5	8.8	37 ft./lb. 35 ft./lb.

METRIC BOLTS

Thread Size	Grade	Plated / Unplated
12mm-1.25	8.8	70 ft./lb. 65 ft./lb.
12mm-1.5	8.8	66 ft./lb. 61 ft./lb.
12mm-1.75	8.8	65 ft./lb. 60 ft./lb.
14mm-2.0	8.8	104 ft./lb. 97 ft./lb.