



Thank you for purchasing this anti-sway bar kit. Please read through these instructions before installation.

# Installation Instructions

## Rear Anti-Sway Bar Kit for the Ford E450

part #1139-147  
1½" diameter



### INTRODUCTION

Thank you for purchasing this anti-sway bar kit. This kit is designed to improve the handling characteristics of your Ford E450 by reducing the body roll and balancing the weight transfer during cornering. The anti-sway bar kit is engineered for long life and trouble-free performance. For maximum suspension control, use this kit along with our front anti-sway bar kit.

All the hardware needed for installation is included in this kit. Refer to the PARTS LIST in these instructions to identify the parts.

### SUGGESTED TOOLS

The following tools are suggested to complete the installation procedures:

- Assorted wrenches
- Assorted sockets
- General hand tools
- Electric drill

### WARNING

**Failure to follow these instructions can result in property damage, personal injury or even death.**

- If raising the vehicle to install the anti-sway bar, always support the vehicle with jack stands at both frame rails or at the rear axle before working underneath. Ensure that the jack stands are securely positioned, and are rated at or above the weight of the vehicle.
- The installer must read the instructions and use all bolts and parts supplied. Use only the parts supplied by ROADMASTER to install this kit.
- Minor modifications are sometimes necessary due to slight vehicle variations, even for the same year, make and model.
- Regardless of year, make and model, a wide range of options for specific applications may or may not interfere with the installation. It is the installer's responsibility to make certain that equipment is not damaged once the suspension solution travels through the full range of motion. Failure to ensure adequate clearance could result in non-warranty property damage, personal injury or even death.
- If running changes were made by the manufacturer after this kit was designed, there may be weldments, braces, gussets, or other structural items which interfere with the installation. It is the installer's responsibility to allow for these running changes without sacrificing the structural integrity of the anti-sway bar. Failure to securely fasten the anti-sway bar could result in property damage, personal injury or even death.
- ROADMASTER will not be responsible for any damage or injury resulting from any modification or alteration.
- Check ALL the fasteners for tightness before and after road testing the vehicle.
- Do not use this document for custom fabrication, as it may not show all parts or structural components.
- Do not use an air impact wrench when re-installing bolts, as stripped threads may result.
- This anti-sway bar is only warranted for the original installation. Installing a used anti-sway bar on another vehicle is not recommended and will void the warranty.

# PARTS LIST

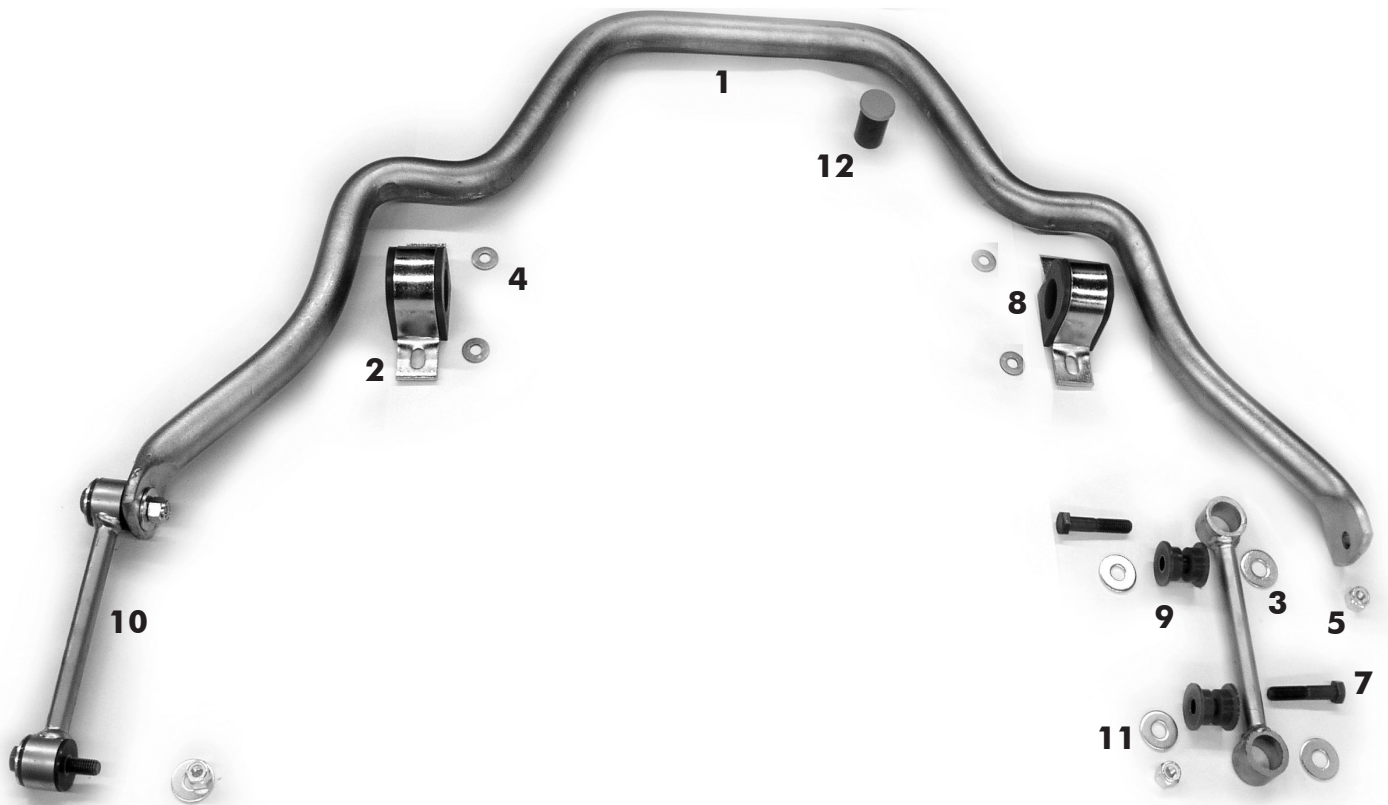

Part #1139-147

Part#	Description	Qty.	Part#	Description	Qty.
1. 580010-00	..... Anti-sway bar, 1½"	1	7. 350101-80	..... Bolt, ½" NC x 3"	4
2. B141	..... Bracket, saddle	2	8. 205217-10	..... Bushing, saddle poly 1-½"	2
3. 350347-00	..... Washer, 9/16" cut.....	4	9. 205223-50	..... Bushing, hat poly	8
4. 350304-80	..... Washer, 3/8" cut.....	4	10. B451	..... End link.....	2
5. 350259-00	..... Nut, ½"	4	11. 350308-00	..... Washer, ½"	4
6. *205522-00	..... Sleeve, 5/8" o.d. x 1-3/8"	4	12..400011-30	.....Aqualube - Grease.....	1

\*not shown

## Free Extended Warranty

You must accurately and completely fill out and mail the product registration card within thirty (30) days from the date of purchase to qualify for your warranty. **If we receive your card, completely and accurately filled out, within twenty (20) days from the date of purchase, we will extend the coverage to a total of two (2) years at no extra charge.**

Your product registration is an important record for ROADMASTER to keep in touch with you. It also enables us to expedite any future claim, update or recall that may arise concerning our products.

# INSTALLATION

The following instructions must be followed in the order listed to ensure a proper installation and to preserve the ROADMASTER warranty.

**1. Remove the factory endlinks.**

Disconnect the endlink from the frame rail.

**2. Remove the factory anti-sway bar from the axle.**

Remove the brackets holding the anti-sway bar to the axle.

**⚠ WARNING**

Removing the brackets will release the anti-sway bar. The anti-sway bar is heavy, and may cause property damage or personal injury if it falls on equipment, engine components or any part of your body. Ensure that the anti-sway bar is supported and that you are out of the way when removing the brackets.

Failure to follow these instructions may cause property damage, personal injury or even death.

**3. Lubricate the bushings with the provided grease (Figure 1).**

Put a thorough coat of grease on the inside of each bushing.

**4. Place the bushings on the anti-sway bar.**

Use the factory anti-sway bar to determine the approximate location for the poly bushings.

**5. Lift the anti-sway bar into place.**

Lift the anti-sway bar into place, placing the saddle brackets over the existing axle mount plates. Reuse the factory bolts to reduce waste. Center the bar and tighten it to 45-55 ft.-lbs.

**6. Connect the endlink to the bar.**

Assemble the poly hat bushings, sleeves, and washers as illustrated in Figure 2. Attach the endlinks to the outside of the bar. Using 3 1/2" bolts, assemble the lower link bolts (just finger-tight for now).

**7. Mount the endlink to the frame rail.**

*Note: the included endlink mounts to the frame in a different location than the factory link. Refer to Figure 3 and Figure 4.*

Mark the endlink bolt location about 4.5" from the bottom of frame rail. The (front to back) vertical location is set where the endlink is straight up and down. (This is done with the vehicle at normal ride height.) Drill a 17/32" hole in this spot.

*Note: check the inside frame rail for possible interference before drilling.*

Assemble the endlinks referring to the parts list for the proper order. Mount the endlink to the frame using a 3" bolt, and washers with the larger center hole on the outside of end link. Use the washer with the slightly smaller center hole on the inside of the frame rail. Secure in place using the nut provided. Tighten the upper and lower link bolts to 45-55 ft.-lbs.

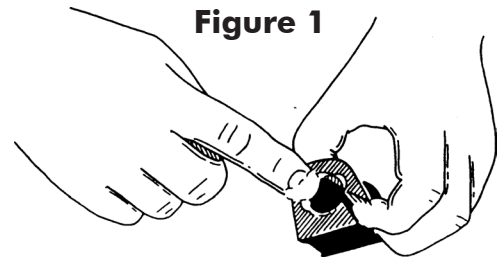

Figure 1



Figure 2

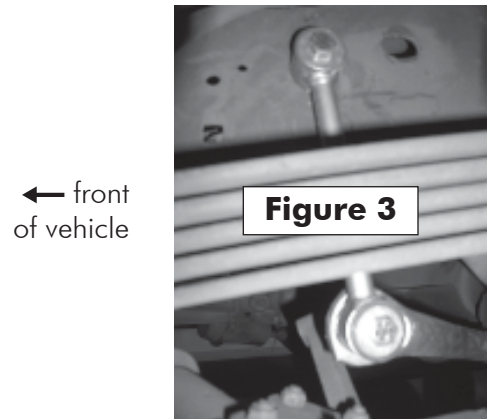

Figure 3

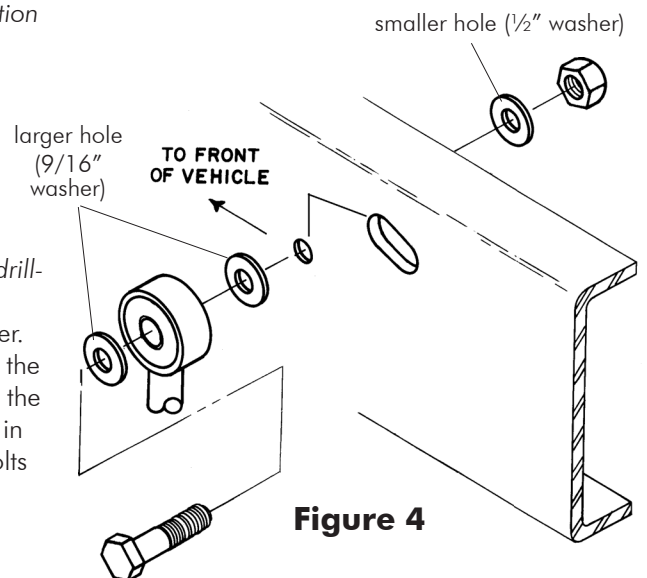

Figure 4

## 8. After road testing, re-check all fasteners for proper tightness

### **WARNING**

After road testing, re-check all fasteners for proper tightness — if a fastener has worked loose or fallen off, re-tighten or replace it. Without all kit components properly tightened or in place, the sway bar will not stabilize the vehicle at full capacity, which may cause reduced cornering ability or other reductions in vehicle handling or performance.

Failure to follow these instructions may result in property damage, personal injury or even death.

### **WARNING**

#### **The anti-sway bar is not a load-bearing component**

Do not tow or hoist the vehicle using the anti-sway bar or its mounting brackets as attachment points. The anti-sway bar is not designed to carry the weight of the vehicle and may collapse, which will damage the anti-sway bar components, the suspension, or other components. The vehicle will detach or fall, which may cause severe personal injury.

Failure to follow these instructions may result in property damage, personal injury or even death.