



Thank you for purchasing this anti-sway bar kit. Please read through these instructions before installation.

Installation Instructions

Rear Anti-Sway Bar for Suburban-Yukon XL Pickup

part #1109-160, #1109-167
1-1/4" diameter



*** If a 4" lift kit is installed, you will need the 590045-00 endlink kit.**

INTRODUCTION

Thank you for purchasing the rear anti-sway bar kit. This kit is designed to improve the handling characteristics of your Suburban or Yukon XL by reducing the body roll and balancing the weight transfer during cornering. The anti-sway bar kit is engineered for long life and trouble-free performance.

All the hardware needed for installation is included in this kit. Refer to the PARTS LIST in these instructions to identify the parts.

SUGGESTED TOOLS

The following tools are suggested to complete the installation procedures:

- General hand tools
- Drill bits
- Center punch
- Torque wrench

WARNING

Failure to follow these instructions can result in property damage, personal injury or even death.

- If raising the vehicle to install the anti-sway bar, always support the vehicle with jack stands at both frame rails or at the rear axle before working underneath. Ensure that the jack stands are securely positioned, and are rated at or above the weight of the vehicle.
- The installer must read the instructions and use all bolts and parts supplied. Use only the parts supplied by ROADMASTER to install this kit.
- Minor modifications are sometimes necessary due to slight vehicle variations, even for the same year, make and model.
- Regardless of year, make and model, a wide range of options for specific applications may or may not interfere with the installation. It is the installer's responsibility to make certain that equipment is not damaged once the suspension solution travels through the full range of motion. Failure to ensure adequate clearance could result in non-warranty property damage, personal injury or even death.
- If running changes were made by the manufacturer after this kit was designed, there may be weldments, braces, gussets, or other structural items which interfere with the installation. It is the installer's responsibility to allow for these running changes without sacrificing the structural integrity of the anti-sway bar. Failure to securely fasten the anti-sway bar could result in property damage, personal injury or even death.
- ROADMASTER will not be responsible for any damage or injury resulting from any modification or alteration.
- Check ALL the fasteners for tightness before and after road testing the vehicle.
- Do not use this document for custom fabrication, as it may not show all parts or structural components.
- Do not use an air impact wrench when re-installing bolts, as stripped threads may result.
- This anti-sway bar is only warranted for the original installation. Installing a used anti-sway bar on another vehicle is not recommended and will void the warranty.

PARTS LIST

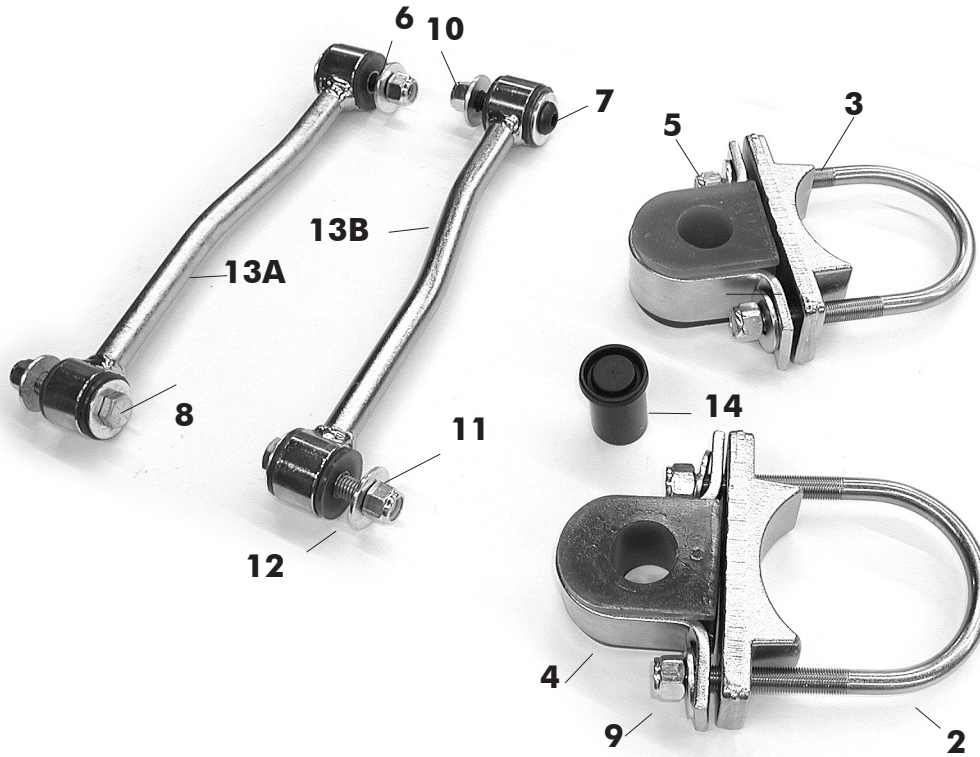

Part #1109-160, # 1109-167

Part #	Description	Qty	Part #	Description	Qty		
1.	580015-00*	Rear sway bar	1	9.	350259-01	Nylock nut, fine	4
2.	357359-00	U-bolt	2	10.	350259-00	Nylock nut, coarse	4
3.	480013	Cast axle bracket	2	11.	350308-00	Washer	12
4.	B141	Bushing clamp	2	12.	205501-00	Sleeve	4
5.	205221-10	Poly bushing	2	13A.	B410	Endlink (Yukon•Suburban)	2
6.	205223-00	Hat bushing	8	13B.	B355	Endlink (Pickups)	2
7.	350099-88	Bolt, button head	2	14.	400011-30	Aqualube - Grease	1
8.	350101-80	Bolt, 1/2" x 3"	2				

*not shown

INSTALLATION

The following instructions must be followed in the order listed to ensure a proper installation and to preserve the **ROADMASTER** warranty.

1. Raise the rear of the vehicle, remove the rear tires and place jackstands under the rear axle. The ideal stand location is at the outermost point under the spring plates.
2. Lube the bushings and install them on the anti-sway bar near the 90-degree bend. Put the u-brackets on the bushings.
3. Install the u-bolts on the axle tube just inside of the shock brackets. Be sure to slip the u-bolt under any brake lines (Figure 1, 2).
4. Place the cast brackets onto u-bolts. Hint: two large rubber bands are helpful in holding the cast brackets in place while the anti-sway bar is being lifted into place.
5. Raise the bar into place (Figure 3). *Note:* the dip in the center of the bar faces down to provide clearance to the rear end. the arms of the bar face the rear of the vehicle. Secure using the washers and nuts (350259-01) provided. Mount the bar so that there is 1/8" to 1/4" clearance between the anti-sway bar and the shock brackets. Torque the u-bolts to 60-70 ft.-lbs.
6. Assemble the endlinks using the bushings and sleeves. Mount the endlink loosely to the inner side of the anti-sway bar using hex head bolts (350101-80), washers (350308-00) and nuts (350259-00). The longest straight section of the end link is attached to the frame.
7. Rotate the arms of the bar up so that the endlink is straight up and down when viewed from the side, and the anti-sway bar arm is parallel to the road. Mark the location for the upper endlink mount on the frame. Check inside the frame for possible interference. Drill holes for the upper mount in the frame rail. Start with a 1/8 inch pilot hole and finish with a 1/2" hole. Install the upper end of the link using the button head bolts (350099-00), washers (350308-00) and nuts (350259-00). Torque the endlink bolts to 40-45 ft.-lbs (Figure 2, 3).
8. Reinstall the wheels and lower the vehicle. Tighten all bolts. Torque the u-bolts to 65 ft./lbs.
9. Road test. Listen for noises. Reinspect fasteners.

Figure 1



Figure 2

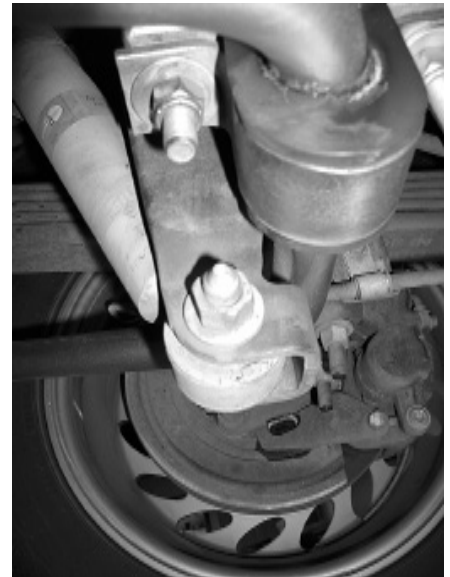

Figure 3



WARNING

The anti-sway bar is not a load-bearing component

Do not tow or hoist the vehicle using the anti-sway bar or its mounting brackets as attachment points. The anti-sway bar is not designed to carry the weight of the vehicle and may collapse, which will damage the anti-sway bar components, the suspension, or other components. The vehicle will detach or fall, which may cause severe personal injury. Failure to follow these instructions may result in property damage, personal injury or even death.

BOLT TORQUE REQUIREMENTS

STANDARD BOLTS			U-BOLTS	
<i>Thread</i>	<i>Grade</i>	<i>Torque</i>	<i>Thread</i>	<i>Torque</i>
3/8.....	5.....	30 lb-ft	3/8-24	35 lb-ft
7/16.....	5.....	50 lb-ft	1/2-20	70 lb-ft
1/2.....	5.....	75 lb-ft	5/8-18	140 lb-ft
5/8.....	5.....	140 lb-ft	3/4-16	250 lb-ft
			7/8-14	400 lb-ft

Note: Endlink bolts use grommets and should NOT be torqued. Tighten these bolts by hand until the grommet starts to deform. Also, these torque values are intended as general guidelines. Roadmaster does not warrant this information to be accurate for all applications and disclaims all liability for any claims or damages which may result from its use.