

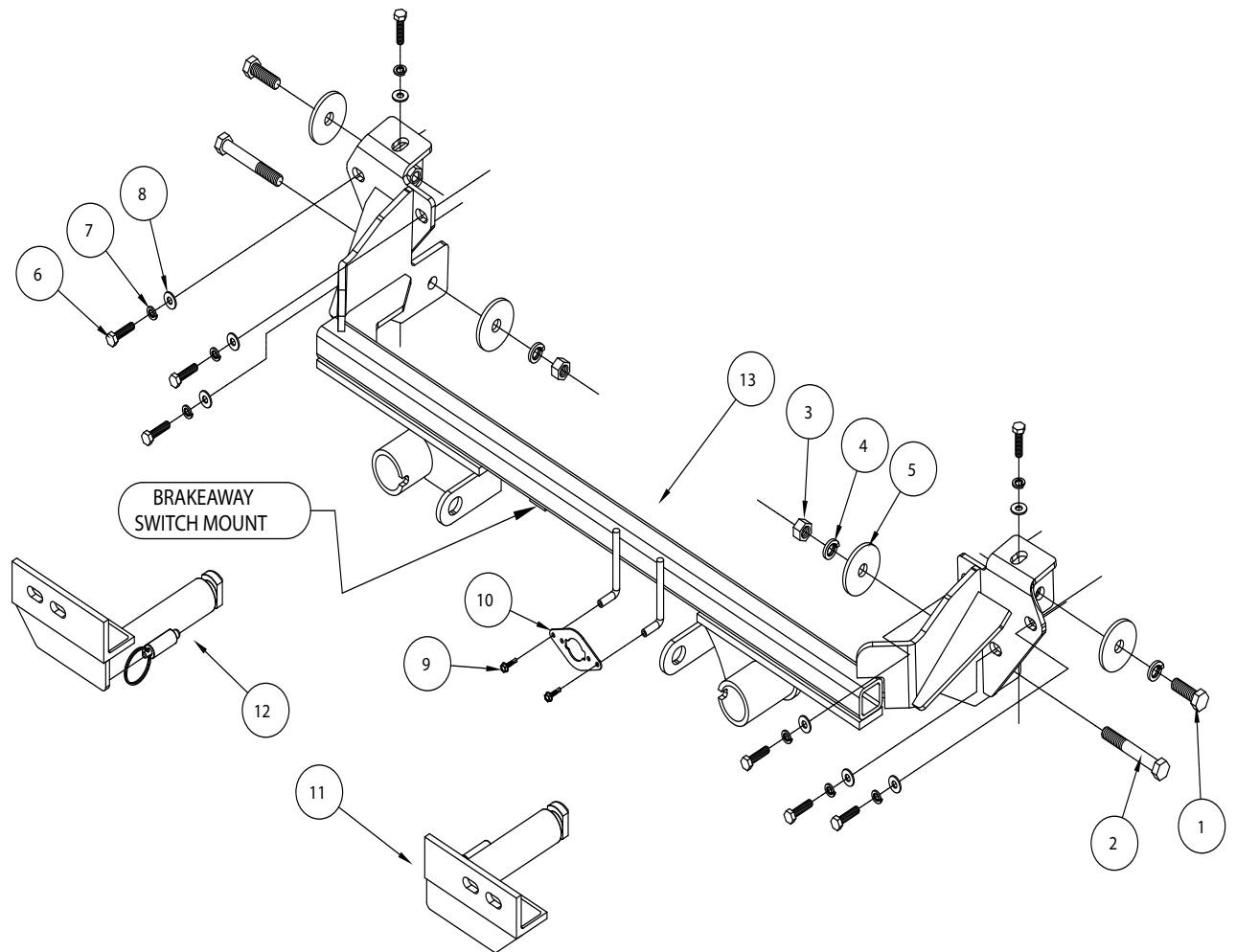

# BASEPLATE KIT INSTALLATION INSTRUCTIONS

**KIT# 521559-4**



ITEM	QTY	NAME	PART #
1	2	1/2" x 1 1/2" BOLT	350095-00
2	2	1/2" x 3 1/2 BOLT	350103-00
3	2	1/2" NUT	350258-00
4	4	1/2" LOCK WASHER	350309-00
5	4	1/2" PLATE WASHER	A-003086
6	8	8mm x 1.25 x 30mm BOLT	356001-00
7	8	8mm LOCK WASHER	355705-00
8	8	5/16" FLAT WASHER	350303-20
9	2	#10 x 3/4" SELF DRILLING SCREW	350247-35
10	1	WIRE PLUG PLATE	A-003801
11	1	DRIVER SIDE ARM	C-003041
12	1	PASSENGER SIDE ARM	C-003042
13	1	MAIN RECEIVER BRACE	C-003043
14	1	1/2" SPLIT WIRING LOOM, 10" LONG	300089-00
15	2	ZIP TIE	300140-10



# BASEPLATE KIT INSTALLATION INSTRUCTIONS

**KIT# 521559-4**

This bracket kit is one of our EZ4 series, which allows the visible front portion of the brackets to be easily removed (Fig.A and Fig.B). The kit consists of the main receiver braces, removable front braces, rear braces, backing plate weldments and a hardware pack.

The main receiver brace mounts to the front frame each side. The removable front braces insert into the receivers on each side.

Before starting the installation, lay out the kit components in order, as they will be used. This will give you a visual idea of how the components work, and will also confirm that everything is present and accounted for.



**IMPORTANT:** All brackets **must** be assembled with all the bolts left loose for final adjustment and positioning (before tightening) unless otherwise instructed. All bolts **must** be torqued for proper strength. If more than one bolt is used per fastening point, the diagram may only show one.

- Use flat washers over all slotted holes
- Use lock washers on all fasteners

## WARNING

Failure to follow these instructions can result in property damage, personal injury or even death.

- Installation of most mounting brackets requires moderate mechanical aptitude and skills. We strongly recommend professional installation by an experienced installer.
- The installer must read the instructions and use all bolts and parts supplied. Failure to do so could result in loss of the towed vehicle.
- Use Loctite® Red on all bolts used for mounting this bracket.
- Every 3,000 miles, the owner must inspect the fasteners for proper torque, according to the bolt torque requirements chart on the last page of these instructions. The owner must also inspect all mounts and brackets for cracks or other signs of fatigue every 3,000 miles. Failure to do so could result in loss of the towed vehicle.
- The owner must check the vehicle manufacturer's instructions for the proper procedure(s) to prepare the vehicle for towing. Some vehicles must be equipped with a transmission lube pump, an axle disconnect, driveline disconnect or free-wheeling hubs before they can be towed. Failure to properly equip the vehicle will cause severe damage to the transmission.
- If running changes were made by the vehicle manufacturer after this bracket was designed, some bolts or other fasteners in the hardware pack may no longer be the correct size. It is the installer's responsibility to verify that the bracket is securely fastened to the vehicle and fitted with the correct hardware to account for these changes. Failure to securely fasten the bracket could result in loss of the towed vehicle.
- If the towed vehicle has been in an accident, it must be properly repaired before attaching the bracket. Do not install the bracket if any structural frame damage is found. Failure to repair the damage could result in the loss of the towed vehicle.
- Roadmaster manufactures many styles of brackets. If your bracket has removable arms, they must be removed before driving the vehicle, unless the arms can be pinned or padlocked in place. If not secured, the arms could vibrate out, resulting in non-warranty damage or personal injury.
- Some motorhome chassis have such a tight turning radius that you can damage your motorhome, towed vehicle, tow bar or bracket while turning sharply. Before getting on the road, test your turning radius in an empty parking lot. Turning too sharply could result in non-warranty damage to towing system, motorhome and/or towed vehicle.
- Do not back up with the towed vehicle attached or non-warranty damage will occur to your towing system, motorhome and/or towed vehicle.
- The safety cables must connect the towing vehicle to the towed vehicle frame to frame, with the cables crossed, with enough slack for sharp turns. Refer to the cable instructions for proper routing. Failure to leave enough slack in the safety cables, or failure to connect the safety cables frame to frame, will result in the loss of the towed vehicle.
- This bracket is designed for use with ROADMASTER tow bars and ROADMASTER adaptors only. Using this bracket with other brands, without an approved ROADMASTER adaptor, may result in non-warranty damage or injury.
- Do not use this document for custom fabrication, as it may not show all parts or structural components. Custom fabrication or an attempt to copy this bracket design could result in loss of the towed vehicle.
- Upon final installation, the installer must inspect the bracket to ensure adequate clearance, particularly around hoses, air conditioner lines, radiators, etc., or non-warranty damage to the towed vehicle will result.
- This bracket is only warranted for the original installation. Installing a used bracket on another vehicle is not recommended and will void the warranty.



# BASEPLATE KIT INSTALLATION INSTRUCTIONS

**KIT# 521559-4**



1. **Important:** please use all supplied bolts and parts and read all instructions carefully before beginning this installation. The majority of questions you may have can be answered within the text, and proper installation will ensure safe and secure travel. Now, begin the installation by removing seven plastic fasteners attaching the radiator cover to the core support (Fig.C).



2. On both sides, remove two screws and one plastic fastener attaching the fender liner to the fascia (Fig.D).
3. Next, on each side, remove one 10mm screw attaching the fender liner to the fascia (Fig.E).
4. Remove four plastic fasteners attaching the splash shield to the fascia (Fig.F).
5. Now, remove the fascia by pulling out and forward on both corners (Fig.G). Disconnect the fog lights, if your vehicle is so equipped.

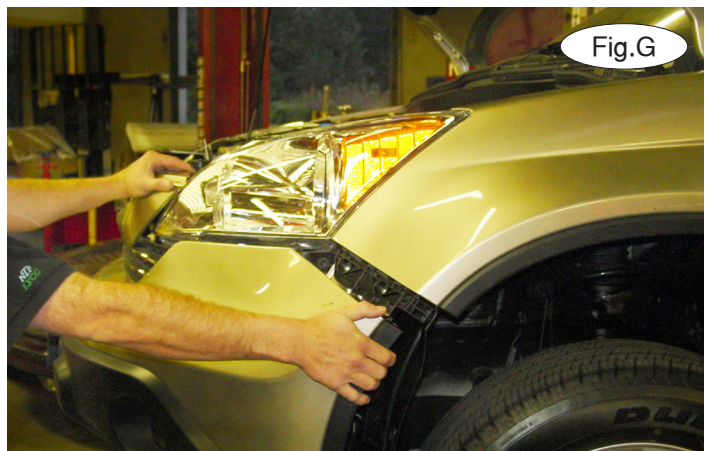



# BASEPLATE KIT INSTALLATION INSTRUCTIONS

**KIT# 521559-4**

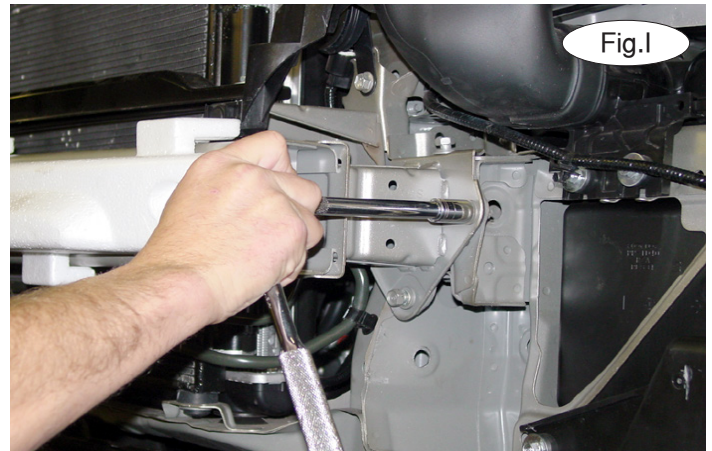
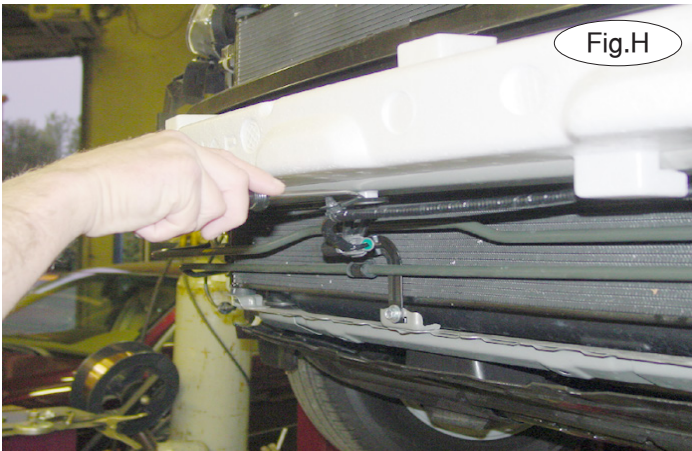

6. Remove the air temperature sensor and wiring harness from the bumper core by removing four plastic fasteners, if the vehicle is so equipped (Fig.H).

7. On each side, remove three 12mm bolts attaching the bumper core to the frame rail (Fig.I). The bumper core will not be replaced. *Note:* retain the bumper core and attachment hardware so that it can be replaced if the bracket is ever removed.

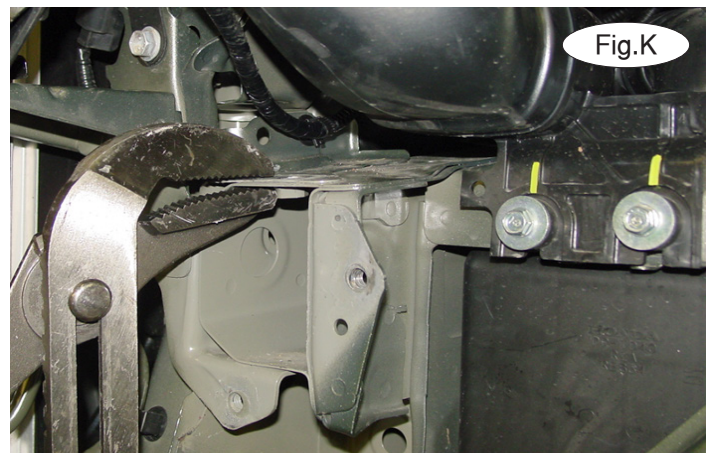
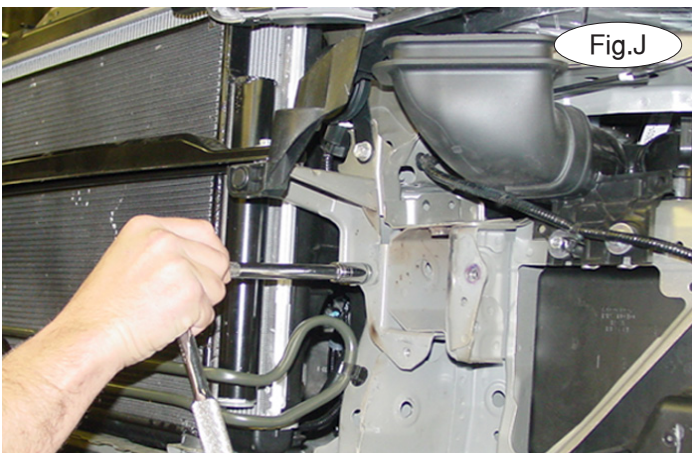

8. On each side, remove two 12mm (head) screws attaching the headlight support bracket to the end of the frame rail (Fig.J). *Note:* if there is a tab located on the top of the frame rail, it must be bent flush with the frame rail before installing the main receiver brace (Fig.K).

9. Next, remove one 10mm bolt attaching the power steering cooling line to the core support, loosening it enough to allow clearance for the main receiver brace (Fig.L).





# BASEPLATE KIT INSTALLATION INSTRUCTIONS

**KIT# 521559-4**

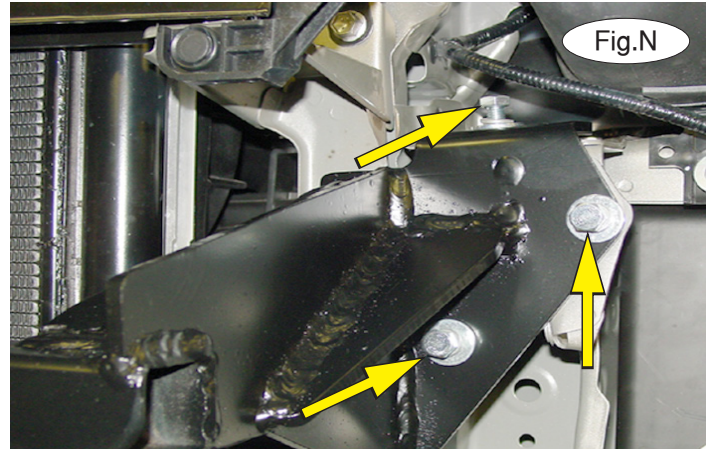
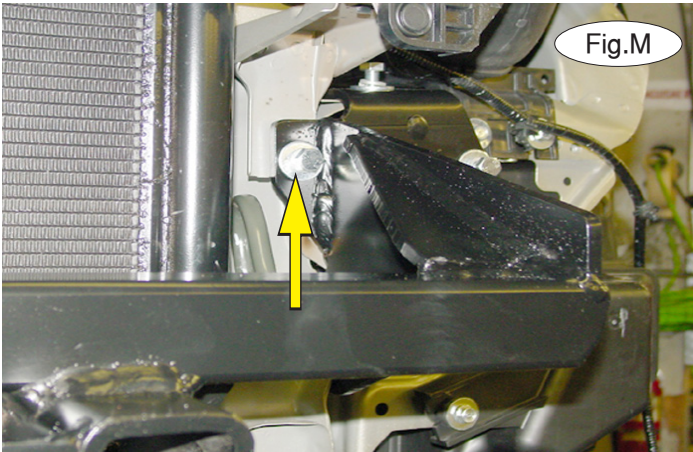

10. Now, set the main receiver brace over the ends of the frame rails. Bolt the main receiver brace into place on each side using the four supplied 8mm x 1.25 x 30mm bolts, 5/16" fender washers and 8mm lock washers (Fig.M,N).

11. Starting with the top bolts, tighten all the bolts to the bolt torque requirements found at the end of this document.

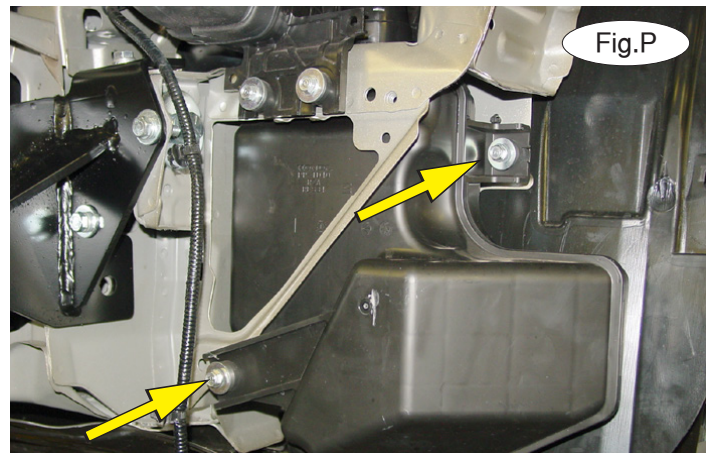
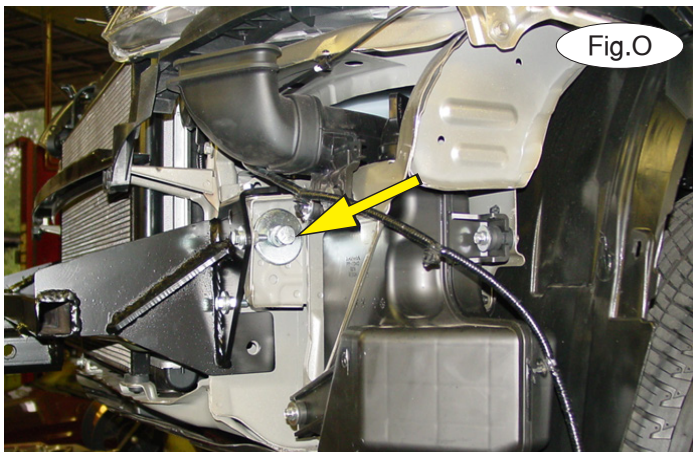

12. Working on one side at a time, use the supplied 1/2" x 1 1/2" bolt, lock washer and plate washer and bolt through the main receiver brace and into the existing hole in the side of the frame rail (Fig.O). Repeat for the other side.

13. The air box and the power steering cooling line need to be temporarily moved to allow room to drill the holes in the core support. Start by removing two 10mm (head) screws from the air box, then pull straight down to remove it (Fig.P).



# BASEPLATE KIT INSTALLATION INSTRUCTIONS

**KIT# 521559-4**

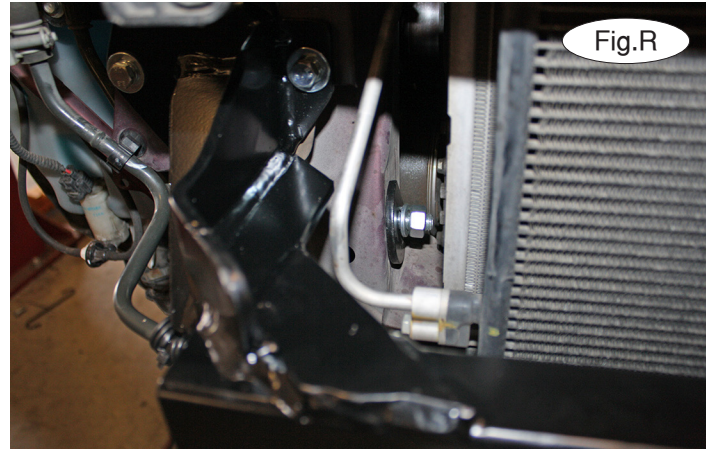

14. Remove the plastic fastener attaching the wiring harness to the inside of the core support on the driver's side. Now, on each side, using the main receiver brace as a template, drill all the way through the core support (Fig.Q). *Note:* before drilling, make certain you will not drill into any engine components on the other side.

15. On each side, attach the main receiver brace to the core support using a 1/2" x 3 1/2" bolt, 1/2" plate washer, lock washer and locknut (Fig.R). Torque to 35 ft./lbs.

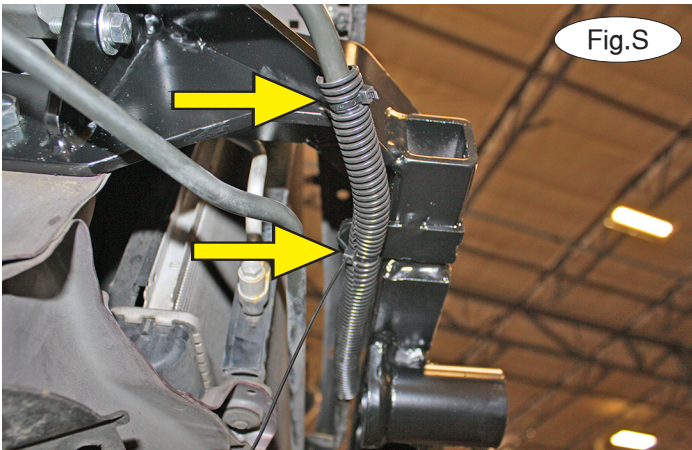

16. Tighten all the remaining bolts to the bolt torque requirements found at the end of these instructions.

17. Reattach the air box and the power steering cooling line, reversing steps 13 and 9. *Note:* due to manufacturing variances, the power steering cooling line may contact the main receiver brace on the passenger side of the vehicle. Use the supplied 10" wiring loom on the power steering cooling line and zip tie it to the hole on the existing tab of the main receiver brace (Fig.S – bottom arrow) and then also on the line beyond where the main receiver brace ends (Fig.S – top arrow).

18. Now, reattach the air temperature sensor to the back of the main receiver brace using the supplied zip tie (Fig.T).



# BASEPLATE KIT INSTALLATION INSTRUCTIONS

**KIT# 521559-4**

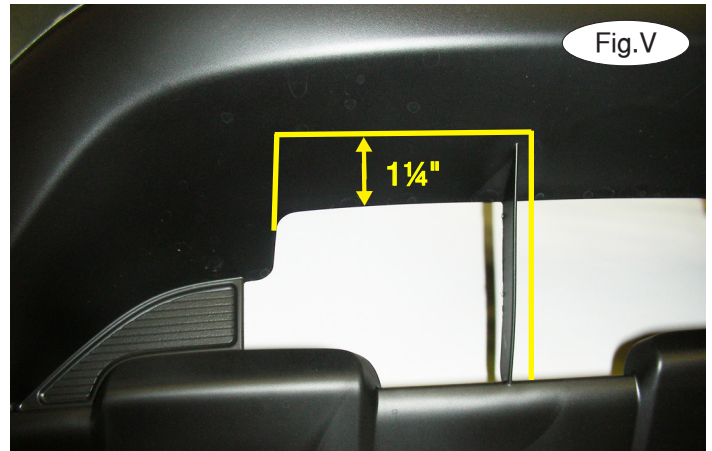
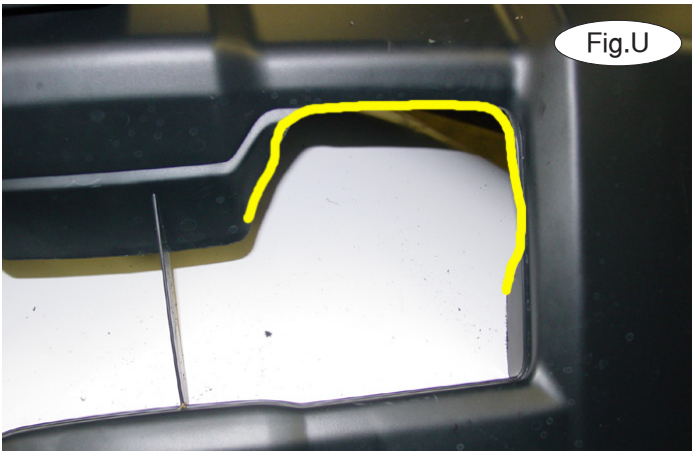

19. **For '07 to '09 models:** on each side, trim the fascia using the yellow lines in Figure U as a guide. **For '10 to '11 models:** on each side, reference Figure V as a guide for trimming.
20. Reinstall the fascia and splash shield, reversing steps 1 through 5.



21. **Note: the following four images are for illustration purposes only, as your specific application may be slightly different.**

The spring-loaded pin on the removable arm snaps into a notch on the receiver, locking the removable arm into its final towing position. Before inserting each arm into the receiver, verify that the spring is working by ensuring that the spring-loaded pin moves easily back and forth within the barrel when pulled and that it can be pulled flush with the face of the barrel (Fig.W and Fig.X).



# BASEPLATE KIT INSTALLATION INSTRUCTIONS

**KIT# 521559-4**

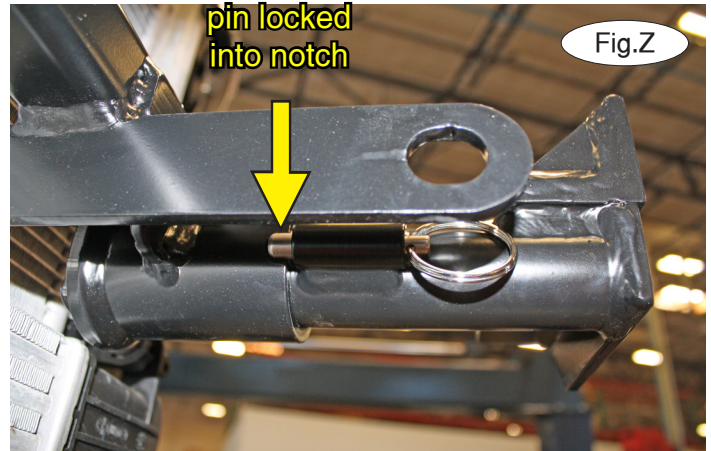

22. On each side, insert the removable front bracket arm into the front receiver 90 degrees from its final towing position, depressing the spring-loaded pin against the receiver (Fig.Y). Now, twist back 90 degrees until the spring-loaded pin snaps into place in the notch on the receiver, locking the arm into place in its final towing position (Fig.Z).

**Please note: it is the owner's responsibility to ensure the locking of the pins before towing. Otherwise, failure of the towing system will result.**

23. Install the tow bar to the mounting bracket according to the manufacturer's instructions.

### **IMPORTANT!**

**Safety cables are required by law. When towing, connect safety cables to the safety cable tabs illustrated in Figure AA. Make certain there is adequate slack in the cables to allow a full turning radius; otherwise, damage will result. If necessary, longer cables or cable extensions are available.**

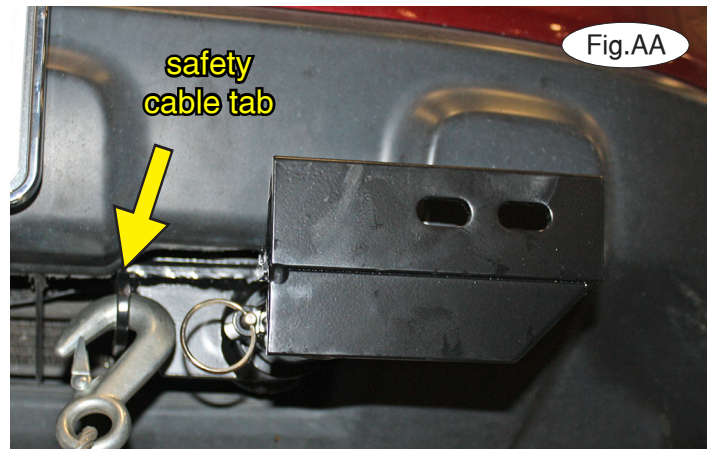





# BASEPLATE KIT INSTALLATION INSTRUCTIONS

**KIT# 521559-4**

## Three options for attaching the wiring plug to the main receiver brace

**For six-wire plugs:** use the two supplied 3/4" self-tapping screws to attach the electrical plug directly to the rods on the front of the main receiver brace.

**For four-wire round plugs:** attach to the plug mounting plate and then use the two supplied 3/4" self-tapping screws to attach the mounting plate to the rods on the front of the main receiver brace.

**For four-wire flat plugs:** place the plug through the mounting plug plate, and then secure it using the supplied zip tie on the front of the plug (Fig.BB). Use the two supplied 3/4" self-tapping screws to attach the mounting plate to the rods on the front of the main receiver brace.

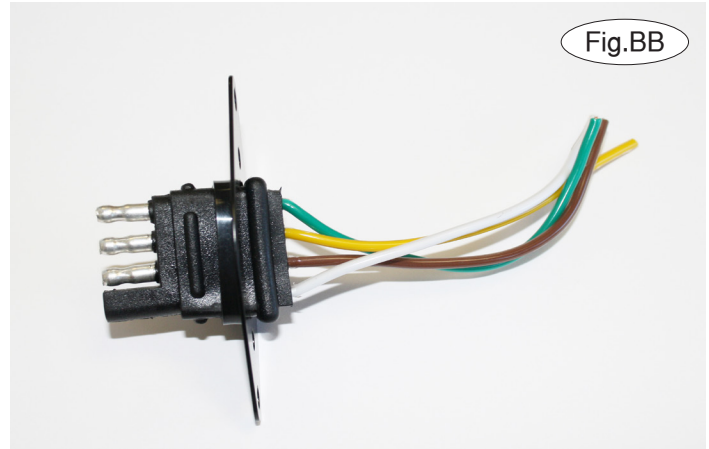

Fig.BB

### BOLT TORQUE REQUIREMENTS

Note: The torque values represented below are intended as general guidelines. Torque requirements for specific applications may vary. Roadmaster does not warrant this information to be accurate for all applications and disclaims all liability for any claims or damages which may result from its use.

#### STANDARD BOLTS

Thread Size	Grade	Torque
5/16-18	5	13 ft./lb.
3/8-16	5	23 ft./lb.
7/16-14	5	37 ft./lb.
1/2-13	5	57 ft./lb.
5/8-11	5	112 ft./lb.

#### METRIC BOLTS

Thread Size	Grade	Torque
6mm-1.0	8.8	6 ft./lb.
8mm-1.0	8.8	18 ft./lb.
8mm-1.25	8.8	16 ft./lb.
10mm-1.25	8.8	36 ft./lb.
10mm-1.5	8.8	31 ft./lb.

#### METRIC BOLTS

Thread Size	Grade	Torque
12mm-1.25	8.8	64 ft./lb.
12mm-1.5	8.8	60 ft./lb.
12mm-1.75	8.8	55 ft./lb.
14mm-2.0	8.8	88 ft./lb.

All illustrations and specifications contained herein are based on the latest information available at the time of publication approval. ROADMASTER, INC. reserves the right to make changes at any time without notice in material, specification and models or to discontinue models.