



# MOUNTING BRACKET KIT INSTALLATION INSTRUCTIONS

**KIT# 495-3A**

12/12/13

**Important**  
 Note: this bracket will not accommodate the Guardian rock shield, some models of the Tow Defender, Stowaway or the StowMaster and StowMaster All Terrain tow bars.

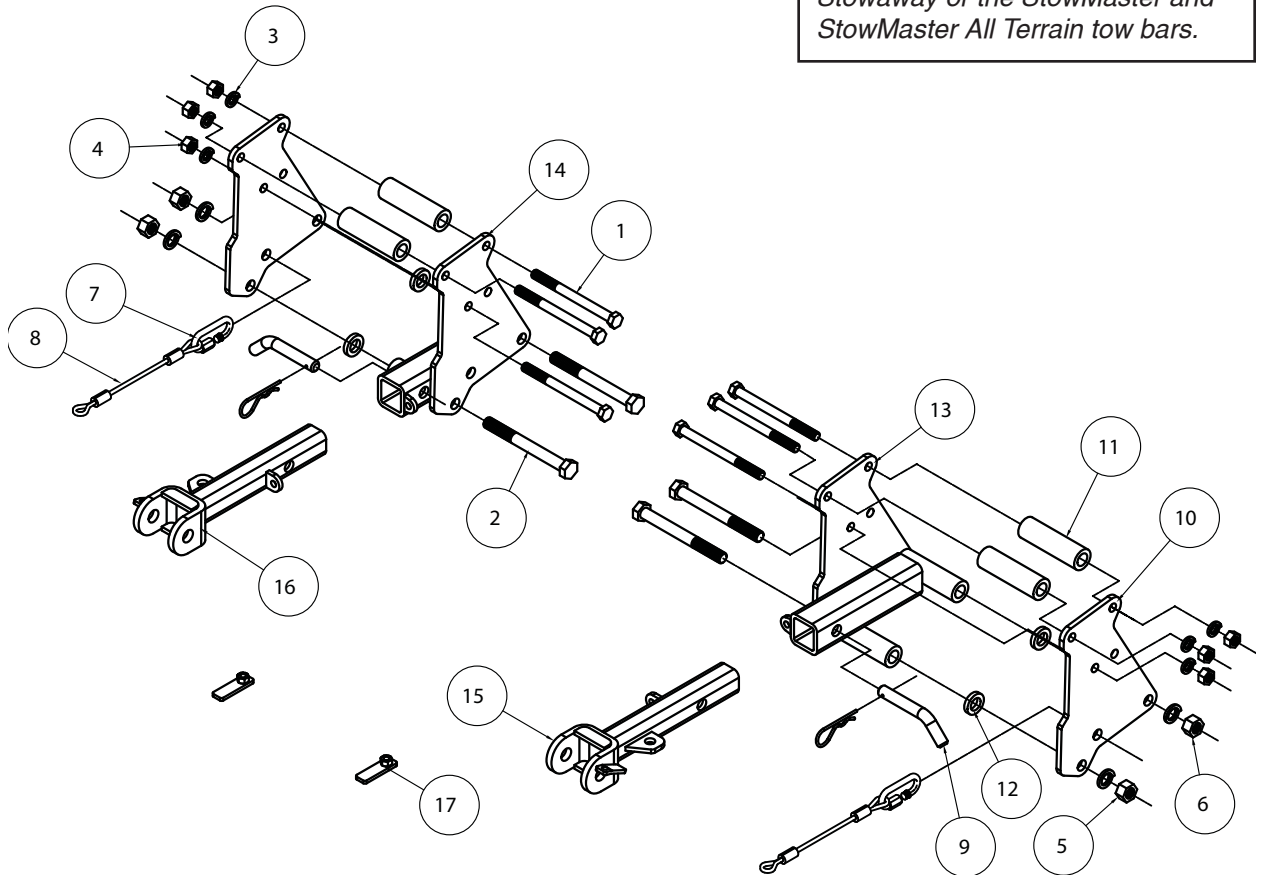

ITEM	QTY	NAME	MATERIAL
1.....	6	1/2" x 6" BOLT.....	350109-00
2.....	4	5/8" x 6" BOLT.....	350162-00
3.....	6	1/2" LOCK WASHER.....	350309-00
4.....	6	1/2" NUT.....	350258-00
5.....	4	5/8" LOCK WASHER.....	350313-00
6.....	4	5/8" NUT.....	350262-00
7.....	2	QUICK LINK.....	200008-00
8.....	2	SAFETY CABLE 15".....	650648-15
9.....	2	DRAW PIN/SPRING PIN.....	357035-00
10.....	2	MOUNTING PLATE.....	A-001277
11.....	4	1 1/4" O.D. x 4 1/4" PIPE SPACER.....	A-001278
12.....	4	1 1/4" O.D. x 1/4" PIPE SPACER.....	A-002726
13.....	1	DRIVER SIDE RECEIVER.....	C-000766
14.....	1	PASSENGER SIDE RECEIVER.....	C-000767
15.....	1	DRIVER SIDE MX ARM.....	C-000768
16.....	1	PASSENGER SIDE MX ARM.....	C-000769
17.....	2	3/16" x 3/4" x 2 1/2" THREADED BACKING PLATE.....	C-002002



# MOUNTING BRACKET KIT INSTALLATION INSTRUCTIONS

**KIT# 495-3A**

12/12/13

This bracket kit is one of our MX series, which allows you to remove the most visible portion of the bracket (Fig.A). The kit consists of two receiver braces, two front braces and a hardware pack. The receiver braces are designed to mount to the frame tubes on each side in place of the existing tow hooks. Start by laying out the kit as illustrated to check parts and placement of parts.



**IMPORTANT:** All brackets **must** be assembled with all the bolts left loose for final adjustment and positioning (before tightening) unless otherwise instructed. All bolts **must** be torqued for proper strength. If more than one bolt is used per fastening point, the diagram may only show one.

- Use flat washers over all slotted holes
- Use lock washers on all fasteners

ROADMASTER Limited Warranty, including One-Year Conditional Warranty Text and Product Registration Card, in Carton.

## WARNING

Failure to follow these instructions can result in property damage, personal injury or even death.

- Installation of most mounting brackets requires moderate mechanical aptitude and skills. We strongly recommend professional installation by an experienced installer.
- The installer must read the instructions and use all bolts and parts supplied. Failure to do so could result in loss of the towed vehicle.
- Use Loctite® Red on all bolts used for mounting this bracket.
- Every 3,000 miles, the owner must inspect the fasteners for proper torque, according to the bolt torque requirements chart on the last page of these instructions. The owner must also inspect all mounts and brackets for cracks or other signs of fatigue every 3,000 miles. Failure to do so could result in loss of the towed vehicle.
- The owner must check the vehicle manufacturer's instructions for the proper procedure(s) to prepare the vehicle for towing. Some vehicles must be equipped with a transmission lube pump, an axle disconnect, driveline disconnect or free-wheeling hubs before they can be towed. Failure to properly equip the vehicle will cause severe damage to the transmission.
- If running changes were made by the vehicle manufacturer after this bracket was designed, some bolts or other fasteners in the hardware pack may no longer be the correct size. It is the installer's responsibility to verify that the bracket is securely fastened to the vehicle and fitted with the correct hardware to account for these changes. Failure to securely fasten the bracket could result in loss of the towed vehicle.
- If the towed vehicle has been in an accident, it must be properly repaired before attaching the bracket. Do not install the bracket if any structural frame damage is found. Failure to repair the damage could result in the loss of the towed vehicle.
- Roadmaster manufactures many styles of brackets. If your bracket has removable arms, they must be removed before driving the vehicle, unless the arms can be pinned or padlocked in place. If not secured, the arms could vibrate out, resulting in non-warranty damage or personal injury.
- Some motorhome chassis have such a tight turning radius that you can damage your motorhome, towed vehicle, tow bar or bracket while turning sharply. Before getting on the road, test your turning radius in an empty parking lot. Turning too sharply could result in non-warranty damage to towing system, motorhome and/or towed vehicle.
- Do not back up with the towed vehicle attached or non-warranty damage will occur to your towing system, motorhome and/or towed vehicle.
- The safety cables must connect the towing vehicle to the towed vehicle frame to frame, with the cables crossed, with enough slack for sharp turns. Refer to the cable instructions for proper routing. Failure to leave enough slack in the safety cables, or failure to connect the safety cables frame to frame, will result in the loss of the towed vehicle.
- This bracket is designed for use with ROADMASTER tow bars and ROADMASTER adaptors only. Using this bracket with other brands, without an approved ROADMASTER adaptor, may result in non-warranty damage or injury.
- Do not use this document for custom fabrication, as it may not show all parts or structural components. Custom fabrication or an attempt to copy this bracket design could result in loss of the towed vehicle.
- Upon final installation, the installer must inspect the bracket to ensure adequate clearance, particularly around hoses, air conditioner lines, radiators, etc., or non-warranty damage to the towed vehicle will result.
- This bracket is only warranted for the original installation. Installing a used bracket on another vehicle is not recommended and will void the warranty.



# MOUNTING BRACKET KIT INSTALLATION INSTRUCTIONS

**KIT# 495-3A**

12/12/13

For 2004-2008 Ford F150 models without tow hooks, follow steps 1 through 3, then on to step 13. For sport models, start with step 4, then on to step 13. For 2009 and later Ford F150 models, begin with step 13 and use Figure Y as a guide for trimming. If your vehicle is equipped with tow hooks, start with step 5.

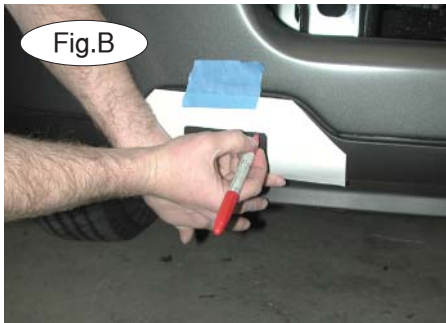

1. **Important:** please use all supplied bolts and parts and read all instructions carefully before beginning this installation. The majority of questions you may have can be answered within the text, and proper installation will ensure safe and secure travel. Now, begin the installation. Cut out the provided F-150 template on the second to last page of these instructions.

2. Tape the template to the fascia, referring to Figure B for correct placement. Now, trace the opening as a guide for correct trimming.

3. Using a reciprocating saw or die grinder, cut along the line you marked in the previous step (Fig.C). Proceed to step 6 to complete the installation.

*Note:* you will need pliers to insert the spring pin (Fig.D), or you can cut the hole in the lower fascia larger to allow access to the pin without the pliers.

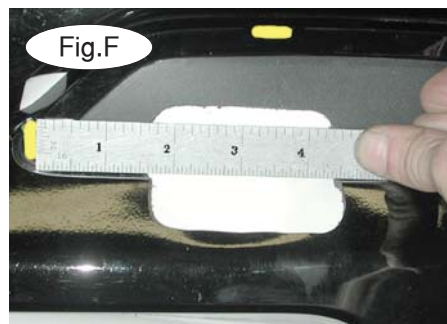
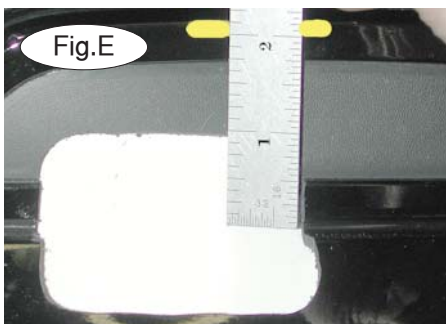

4. On each side, measure approximately 2" down from the top of the trim line (Fig.E), and 3/4" from the side (Fig.F), using the yellow marker lines as a reference. Drill a 1/2" pilot hole at this point. Enlarge the opening with a die grinder, using the receiver brace directly below as a reference, until the opening is large enough for the removable front brace (Fig.G).

5. Remove the tow hooks on each side by removing two front bolts and loosening the rear bolts (Fig.H). Slide the hooks back off the rear bolt (Fig.I). *Note:* on models without tow hooks, there will be no front bolts to replace.

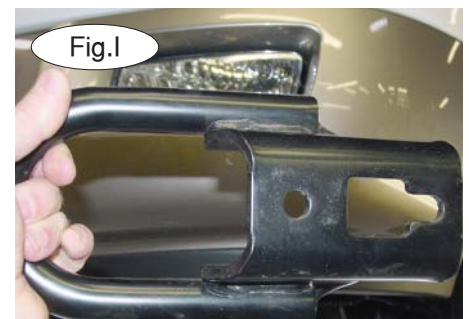



# MOUNTING BRACKET KIT INSTALLATION INSTRUCTIONS

**KIT# 495-3A**

12/12/13

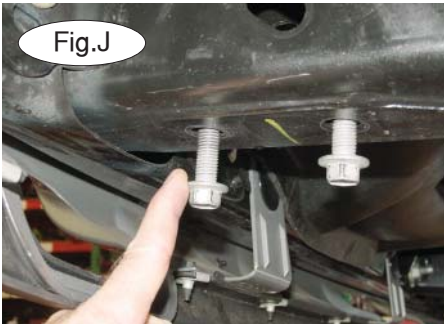

6. Now put the front bolts back in and tighten down (Fig.J), then remove the rear bolt on each side (Fig.K).

7. **For 2009 and later models:** due to manufacturing variances, some models may be equipped with a rock guard. This guard can either be removed or relocated. Remove two 13mm (head) bolts attaching the rock guard to the bottom of the frame (Fig.L – driver's side). If you are relocating this guard, proceed to step 8. If you are removing it, proceed to step 12.

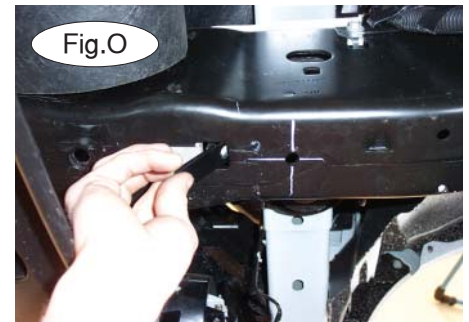
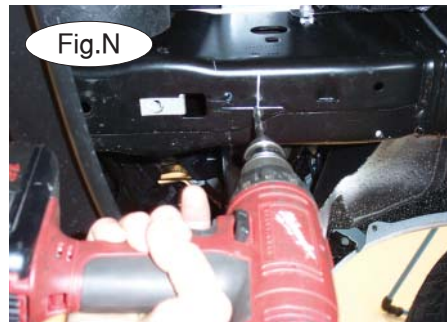
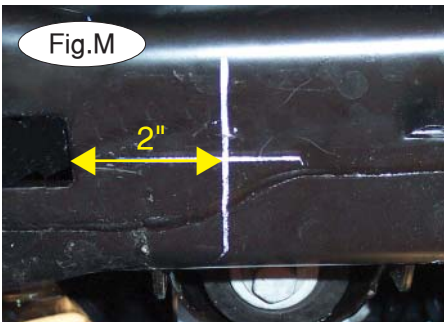

8. On each side, locate a square hole in the bottom of the frame rail. Measure 2" back from the hole, and find the center of the frame (Fig.M – passenger side).

9. On each side, use a 7/16" drill bit to drill a hole at the center point (Fig.N).

10. On each side, insert one of the supplied 3/16" x 3/4" x 2 1/2" nutted backing plates into the square hole (Fig.O) and over the hole you drilled in the previous step.



11. Hold the backing plate in place and using the bolts you removed in step 8, bolt through the rock guard, frame rail and into the backing plate (Fig.P).

12. Working on one side at a time, find the hole in the frame located above the tow hook mounting area and put a 1/2" x 6" bolt through the brace and the frame from the inside of the frame (Fig.Q,R,S). **For 2004-2008 models:** use the front hole in the side plate. **For 2009 and later models:** use the rear hole in the side plate.





# MOUNTING BRACKET KIT INSTALLATION INSTRUCTIONS

**KIT# 495-3A**

12/12/13



- Put two bolts over the top of the frame then follow with two 4½" pipe spacers (Fig.T).
- Position the outside plate (Fig.U) over the three bolts and two top spacers then secure with ½" lock washers and nuts (Fig.V).

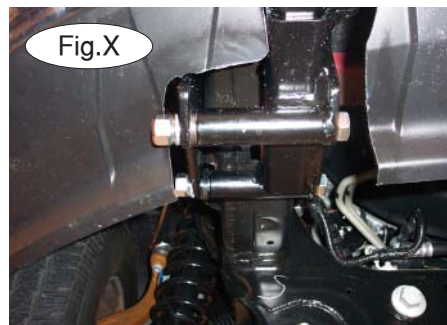
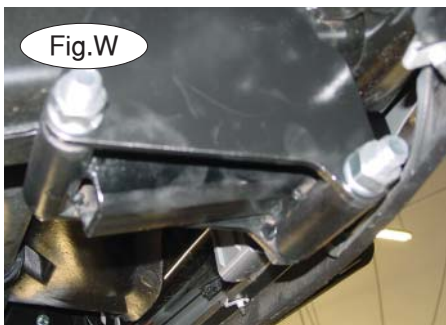

- For 2004-2008 models:** follow with two more 5/8" x 6" bottom bolts, lock washers and nuts (Fig.W). **For 2009 and later models:** use the supplied 1¼" x ¼" spacers between the outside plate and main receiver brace (Fig.X).

11. Repeat steps 13 through 15 for the remaining side and torque all mounting bolts to the specifications below.

- For 2004-2008 models:** use the enclosed template to trim the fascia. **For 2009 and later models without tow hooks:** in the third recessed area of the fascia, measure ¾" inch toward the center, and index the template to the bottom of the fascia. Trace the template, and trim using the white lines in Figure Y as a guide. **For 2009 and later models with tow hooks:** trim the bottom of the tow hook opening in the area denoted with yellow arrows in Figure Z to allow clearance for the main receiver brace.

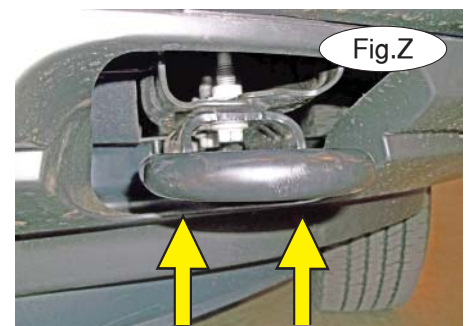

- Insert the front braces into the receiver braces and secure with 5/8" draw pins and 3/16" safety pins.
- Install the tow bar to the mounting bracket according to the manufacturer's instructions. Attach the safety cables to the main receiver brace.

## BOLT TORQUE REQUIREMENTS

Note: The torque values represented below are intended as general guidelines. Torque requirements for specific applications may vary. Roadmaster does not warrant this information to be accurate for all applications and disclaims all liability for any claims or damages which may result from its use.

### STANDARD BOLTS

Thread Size	Grade	Torque
5/16	5	13 ft./lb.
3/8	5	23 ft./lb.
7/16	5	37 ft./lb.
1/2	5	56 ft./lb.
5/8	5	150 ft./lb.

### METRIC BOLTS

Thread Size	Grade	Plated / Unplated
8mm-1.0	8.8	20 ft./lb. 18 ft./lb.
8mm-1.25	8.8	19 ft./lb. 18 ft./lb.
10mm-1.25	8.8	38 ft./lb. 36 ft./lb.
10mm-1.5	8.8	37 ft./lb. 35 ft./lb.

### METRIC BOLTS

Thread Size	Grade	Plated / Unplated
12mm-1.25	8.8	70 ft./lb. 65 ft./lb.
12mm-1.5	8.8	66 ft./lb. 61 ft./lb.
12mm-1.75	8.8	65 ft./lb. 60 ft./lb.
14mm-2.0	8.8	104 ft./lb. 97 ft./lb.



***MOUNTING BRACKET KIT  
INSTALLATION INSTRUCTIONS***

***KIT# 495-3A***  
12/12/13

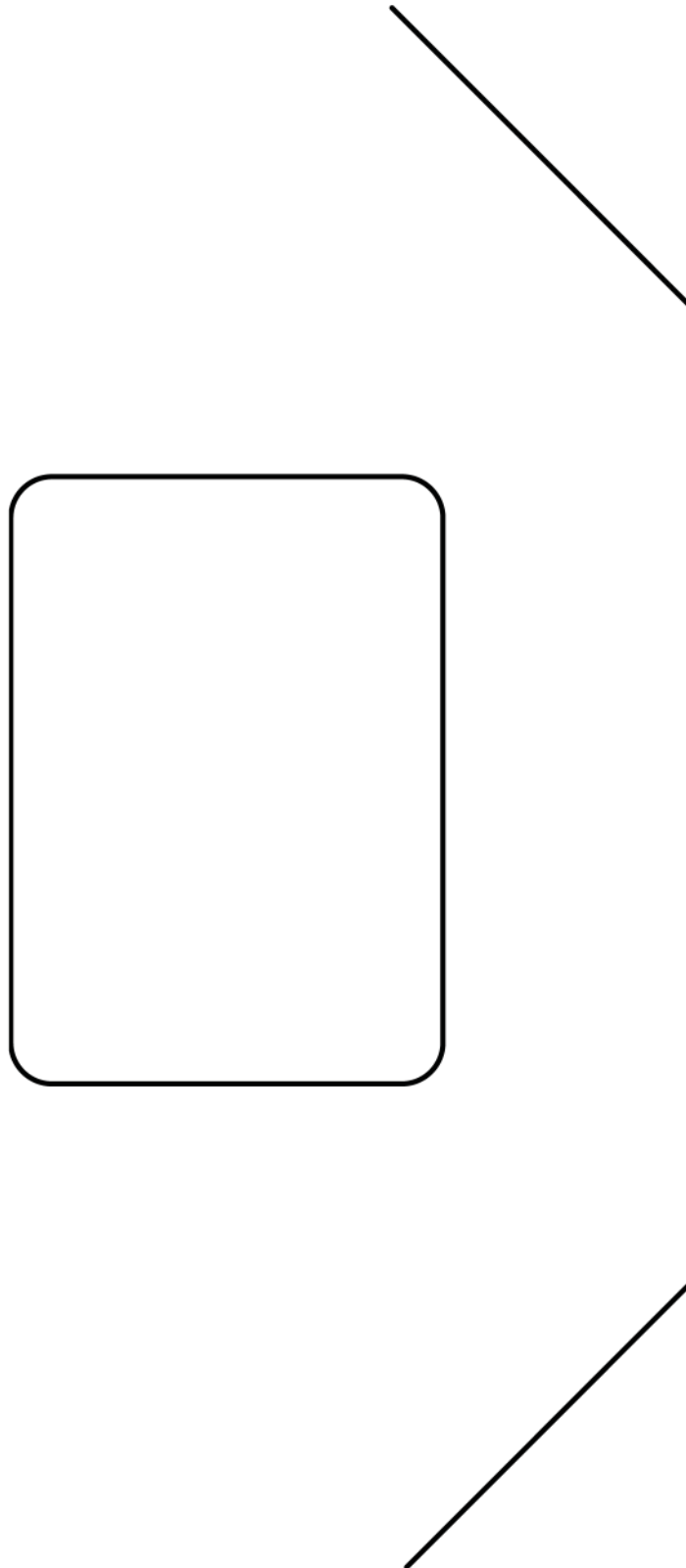

Template for 09 and later  
Ford F-150 fascia trimming

