

# MOUNTING BRACKET KIT

## INSTALLATION INSTRUCTIONS

**PARTS LIST:**

- 1- FRONT BRACE (A) - Passenger side
- 1- FRONT BRACE (B) - Driver side
- 1- MAIN BRACE (C)

KIT NO. 338-1

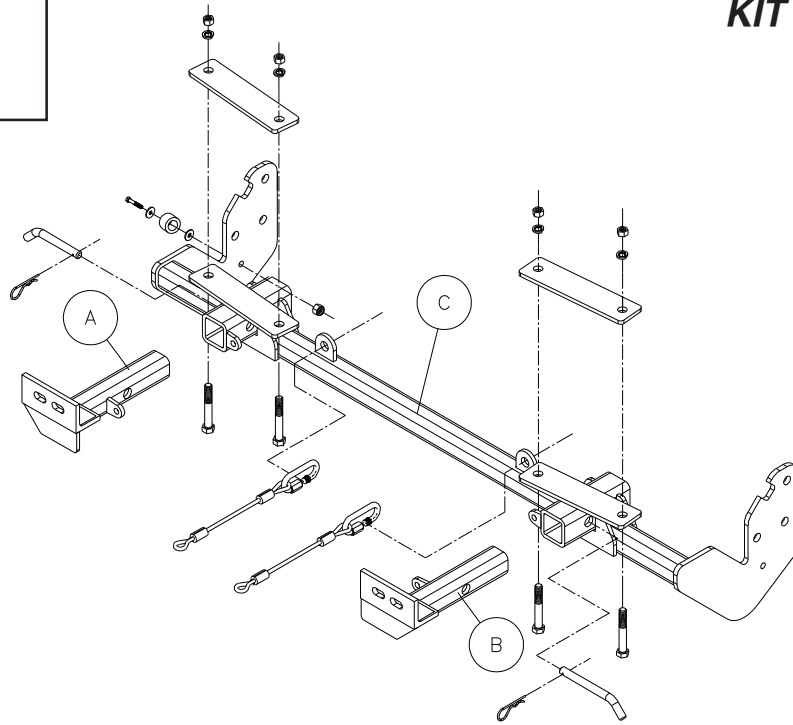

4/22/02

**IMPORTANT:** All brackets *must* be assembled with all the bolts left loose for final adjustment and positioning (before tightening) unless otherwise instructed. All bolts *must* be torqued for proper strength. If more than one bolt is used per fastening point, the diagram may only show one.

- Use flat washers over all slotted holes
- Use lock washers on all fasteners

ROADMASTER Limited Warranty, including One-Year Conditional Warranty Text and Product Registration Card, in Carton.

### **WARNING**

Failure to follow these instructions can result in property damage, personal injury or even death.

- Installation of most mounting brackets requires moderate mechanical aptitude and skills. We strongly recommend professional installation by an experienced installer.
- The installer must read the instructions and use all bolts and parts supplied. Failure to do so could result in loss of the towed vehicle.
- Use Loctite® Red on all bolts used for mounting this bracket.
- Do not use this document for custom fabrication, as it may not show all parts or structural components. Custom fabrication or an attempt to copy this bracket design could result in loss of the towed vehicle.
- Every 3,000 miles, the owner must inspect the fasteners for proper torque, according to the bolt torque requirements chart on the last page of these instructions. The owner must also inspect all mounts and brackets for cracks or other signs of fatigue every 3,000 miles. Failure to do so could result in loss of the towed vehicle.
- The owner must check the vehicle manufacturer's instructions for the proper procedure(s) to prepare the vehicle for towing. Some vehicles must be equipped with a transmission lube pump, an axle disconnect, driveline disconnect or free-wheeling hubs before they can be towed. Failure to properly equip the vehicle will cause severe damage to the transmission.
- If running changes were made by the vehicle manufacturer after this bracket was designed, some bolts or other fasteners in the hardware pack may no longer be the correct size. It is the installer's responsibility to verify that the bracket is securely fastened to the vehicle and fitted with the correct hardware to account for these changes. Failure to securely

fasten the bracket could result in loss of the towed vehicle.

- If the towed vehicle has been in an accident, it must be properly repaired before attaching the bracket. Do not install the bracket if any structural frame damage is found. Failure to repair the damage could result in the loss of the towed vehicle.
- Some motorhome chassis have such a tight turning radius that you can damage your motorhome, towed vehicle, tow bar or bracket while turning sharply. Before getting on the road, test your turning radius in an empty parking lot. Turning too sharply could result in non-warranty damage to towing system, motorhome and/or towed vehicle.
- Do not back up with the towed vehicle attached or non-warranty damage will occur to your towing system, motorhome and/or towed vehicle.
- The safety cables must connect the towing vehicle to the towed vehicle frame to frame, with the cables crossed, with enough slack for sharp turns. Refer to the cable instructions for proper routing. Failure to leave enough slack in the safety cables, or failure to connect the safety cables frame to frame, will result in the loss of the towed vehicle.
- This bracket is designed for use with ROADMASTER tow bars and ROADMASTER adaptors only. Using this bracket with other brands, without an approved ROADMASTER adaptor, may result in non-warranty damage or injury.
- Upon final installation, the installer must inspect the bracket to ensure adequate clearance, particularly around hoses, air conditioner lines, radiators, etc., or non-warranty damage to the towed vehicle will result.
- This bracket is only warranted for the original installation. Installing a used bracket on another vehicle is not recommended and will void the warranty.

# MOUNTING BRACKET KIT INSTALLATION INSTRUCTIONS

**KIT NO. 338-1**

1. **Important: please use all supplied bolts and parts and read all instructions carefully before beginning this installation. The majority of questions you may have can be answered within the text, and proper installation will ensure safe and secure travel.** Now, begin the installation. This bracket kit is one of our XL series, which is designed to be partly removable. The kit consists of the main receiver brace, front braces and a hardware pack. The main receiver brace mounts behind the front bumper fascia to the bumper core and front tie down plate mounting area on each side. The front braces insert into the receivers on each side. Start by laying the kit out according to the illustration. This will give you a visual idea of how the kit installs and also confirm that the kit components are present and accounted for. The front grille will have to be trimmed to fit.
2. Start by removing the plastic fasteners in the top of the fascia. These consist of two (10mm head) bolts, one in each corner and four plastic fasteners. Move to the side fender well fascia junction and remove two screws (10mm head) on each side. Remove two more black (Phillip head) screws in the bottom fascia in front of the fender wells. Remove five plastic fasteners from the bottom of the fascia and pull forward and down to remove. If fog lights are present, disconnect then set fascia aside.
3. Remove the front tie down plates on each side (three 14mm head bolts on each side) *Note:* remove the lower washer bottle mounting bolt on the passenger side and lower air canister bolt on the drivers side. Both canister and bottle may have to be pulled away from the frame to access the rear tie down plate bolts. Save the tie down bolts for reuse.
4. Remove the plastic and rubber air deflectors on each side of the radiator.
5. Unclip the ambient air sensor under the bumper and zip tie to its supporting wiring harness.
6. Hold the main receiver brace to the bottom of the bumper core and over the tie down plate mounting area on each side. Bolt through the side mounting plates with the stock bolts removed in step 3. Temporarily clamp the brace to the bottom of the bumper core, then tighten the side bolts to hold in position.
7. Using the receiver brace as a drill template, drill four ½” holes through the bottom two layers of the formed c-channel.
8. Now looking at your illustration, put two ¼” x 2” x 8” backing plates in the middle of the formed u- channel above the holes you just drilled. The object is to sandwich the lower portion of the c-channel. Bolt through the lower c-channel with four 7/16” x 2¾” bolts, lock washers and nuts.
9. Torque all mounting bolts to the torque specifications below.
10. Replace the lower air canister bolt-removed in step 3, then bolt through the lower washer bottle mount with a 6mm x 45mm bolt, flat fender washers and lock nut. Use a ¾” pipe spacer between the bottle mount and the brace. Torque the bolts to the bolt torque requirements below.
11. Trim the air deflectors fit around the receiver brace and reinstall.
12. Reverse step two to reinstall the bumper fascia.

**4/22/02**

## BOLT TORQUE REQUIREMENTS

Note: The torque values represented below are intended as general guidelines. Torque requirements for specific applications may vary. Roadmaster does not warrant this information to be accurate for all applications and disclaims all liability for any claims or damages which may result from its use.

STANDARD BOLTS			METRIC BOLTS			METRIC BOLTS		
Thread Size	Grade	Torque	Thread Size	Grade	Plated/Unplated	Thread Size	Grade	Plated/Unplated
5/16	5	13 ft./lb.	8mm-1.0	8.8	20 ft./lb. 18 ft./lb.	12mm-1.25	8.8	70 ft./lb. 65 ft./lb.
3/8	5	23 ft./lb.	8mm-1.25	8.8	19 ft./lb. 18 ft./lb.	12mm-1.5	8.8	66 ft./lb. 61 ft./lb.
7/16	5	37 ft./lb.	10mm-1.25	8.8	38 ft./lb. 36 ft./lb.	12mm-1.75	8.8	65 ft./lb. 60 ft./lb.
1/2	5	56 ft./lb.	10mm-1.5	8.8	37 ft./lb. 35 ft./lb.	14mm-2.0	8.8	104 ft./lb. 97 ft./lb.
5/8	5	150 ft./lb.						

# MOUNTING BRACKET KIT INSTALLATION INSTRUCTIONS

**KIT NO. 338-1**

13. Insert the front braces into the receiver tubes and pin with 5/8" draw pins and spring pins.
14. Install the tow bar according to the manufacturer's instructions.
15. Attach one end of the 8" safety cables to front holes on the receiver cross bar on each side of the receiver brace with the included cable connectors. Connect the other end to the tow vehicle's safety cables and the tow bar.
16. A universal wiring connector plate is also available for your use on the crossbar.

## Hardware

- 4- 7/16" x 2 3/4" bolts
- 4- 7/16" lock washers
- 4- 7/16" nuts
- 1- 6mm x 1.0 x 45mm bolt
- 2- 6mm fender washers
- 1- 6mm lock nut
- 1- 3/4" pipe spacer
- 1- zip tie
- 2- 8" safety cables
- 2- cable connectors
- 2- 5/8" draw pins
- 2- spring pins
- 2- 2" x 8" backing plates
- 2- 3/16" spring pins

**4/22/02**

## BOLT TORQUE REQUIREMENTS

Note: The torque values represented below are intended as general guidelines. Torque requirements for specific applications may vary. Roadmaster does not warrant this information to be accurate for all applications and disclaims all liability for any claims or damages which may result from its use.

STANDARD BOLTS			METRIC BOLTS			METRIC BOLTS		
Thread Size	Grade	Torque	Thread Size	Grade	Plated/Unplated	Thread Size	Grade	Plated/Unplated
5/16	5	13 ft./lb.	8mm-1.0	8.8	20 ft./lb. 18 ft./lb.	12mm-1.25	8.8	70 ft./lb. 65 ft./lb.
3/8	5	23 ft./lb.	8mm-1.25	8.8	19 ft./lb. 18 ft./lb.	12mm-1.5	8.8	66 ft./lb. 61 ft./lb.
7/16	5	37 ft./lb.	10mm-1.25	8.8	38 ft./lb. 36 ft./lb.	12mm-1.75	8.8	65 ft./lb. 60 ft./lb.
1/2	5	56 ft./lb.	10mm-1.5	8.8	37 ft./lb. 35 ft./lb.	14mm-2.0	8.8	104 ft./lb. 97 ft./lb.
5/8	5	150 ft./lb.						