

MOUNTING BRACKET KIT

INSTALLATION INSTRUCTIONS

PARTS LIST:

- 1- LOWER RECEIVER (A) - Passenger side
- 1- LOWER RECEIVER (B) - Driver's side
- 1- FRONT BRACE (C) - Passenger side
- 1- FRONT BRACE (D) - Driver's side

KIT NO. 175-17

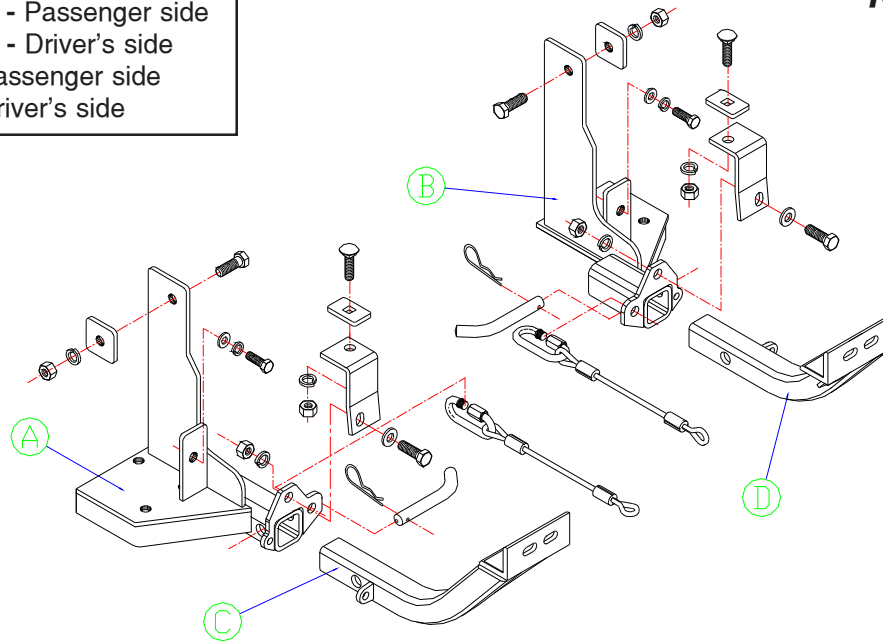

07-10-00

IMPORTANT: All brackets **must** be assembled with all the bolts left loose for final adjustment and positioning (before tightening) unless otherwise instructed. All bolts **must** be torqued for proper strength. If more than one bolt is used per fastening point, the diagram may only show one.

- Use flat washers over all slotted holes
- Use lock washers on all fasteners

ROADMASTER Limited Warranty, including One-Year Conditional Warranty Text and Product Registration Card, in Carton.

WARNING

Failure to follow these instructions can result in property damage, personal injury or even death.

- Installation of most mounting brackets requires moderate mechanical aptitude and skills. We strongly recommend professional installation by an experienced installer.
- The installer must read the instructions and use all bolts and parts supplied. Failure to do so could result in loss of the towed vehicle.
- Use Loctite® Red on all bolts used for mounting this bracket.
- Do not use this document for custom fabrication, as it may not show all parts or structural components. Custom fabrication or an attempt to copy this bracket design could result in loss of the towed vehicle.
- Every 3,000 miles, the owner must inspect the fasteners for proper torque, according to the bolt torque requirements chart on the last page of these instructions. The owner must also inspect all mounts and brackets for cracks or other signs of fatigue every 3,000 miles. Failure to do so could result in loss of the towed vehicle.
- The owner must check the vehicle manufacturer's instructions for the proper procedure(s) to prepare the vehicle for towing. Some vehicles must be equipped with a transmission lube pump, an axle disconnect, driveline disconnect or free-wheeling hubs before they can be towed. Failure to properly equip the vehicle will cause severe damage to the transmission.
- If running changes were made by the vehicle manufacturer after this bracket was designed, some bolts or other fasteners in the hardware pack may no longer be the correct size. It is the installer's responsibility to verify that the bracket is securely fastened to the vehicle and fitted with the correct hardware to account for these changes. Failure to securely

fasten the bracket could result in loss of the towed vehicle.

- If the towed vehicle has been in an accident, it must be properly repaired before attaching the bracket. **Do not install the bracket if any structural frame damage is found.** Failure to repair the damage could result in the loss of the towed vehicle.
- Some motorhome chassis have such a tight turning radius that you can damage your motorhome, towed vehicle, tow bar or bracket while turning sharply. **Before getting on the road, test your turning radius in an empty parking lot.** Turning too sharply could result in non-warranty damage to towing system, motorhome and/or towed vehicle.
- Do not back up with the towed vehicle attached or non-warranty damage will occur to your towing system, motorhome and/or towed vehicle.
- The safety cables must connect the towing vehicle to the towed vehicle frame to frame, with the cables crossed, with enough slack for sharp turns. Refer to the cable instructions for proper routing. Failure to leave enough slack in the safety cables, or failure to connect the safety cables frame to frame, will result in the loss of the towed vehicle.
- This bracket is designed for use with ROADMASTER tow bars and ROADMASTER adaptors only. **Using this bracket with other brands, without an approved ROADMASTER adaptor, may result in non-warranty damage or injury.**
- Upon final installation, the installer must inspect the bracket to ensure adequate clearance, particularly around hoses, air conditioner lines, radiators, etc., or non-warranty damage to the towed vehicle will result.
- This bracket is only warranted for the original installation. Installing a used bracket on another vehicle is not recommended and will void the warranty.

MOUNTING BRACKET KIT INSTALLATION INSTRUCTIONS

KIT NO. 175-17

- Important:** please use all supplied bolts and parts and read all instructions carefully before beginning this installation. The majority of questions you may have can be answered within the text, and proper installation will ensure safe and secure travel. Now, begin the installation. This XL Series bracket consists of two receiver braces, two front braces and a hardware kit. The receiver braces are designed to sandwich between the unitized frame and the lower radiator support. To gain access to the needed areas, the headlights and the plastic radiator cover will have to be removed. Do this now by removing to bolts from the headlights on each side and six plastic retainer buttons from the center plastic section. Next, remove three small screws from the lower plastic air dam on each side of the car. The bumper skin will also have to be removed. Do this by removing four 7mm screws at each fender well, two 10mm screws inside the bumper under the marker lights and four retainer buttons on the top.
- Find the diagonal tubular support braces that are located in front of the radiator. Unbolt the lower end of these braces. *Note:* the bolts will not be replaced. A portion of the main braces will be sandwiched between the frame and the braces later.
- Before proceeding with this step, the lower radiator support should be either blocked or secured to the upper frame so that it doesn't drop if the securing bolts on each side are removed. Once this is done, remove three bolts on each side of the radiator support. Insert a main brace between the upper frame and the lower radiator support and replace the bolts. *Note:* the plastic air dam will have to be trimmed to fit the brace. Be sure the side of the brace is between the frame and the tubular support. Insert the remaining brace on the opposite side and replace the remaining three bolts.
- Replace the tubular diagonal brace bolts that were removed in step two with supplied 8mm x 1.25 x 40mm bolts, flat washers and lock washers. The front mounting tab should be sandwiched between the frame and the tubular braces.
- Insert the front braces into the receivers and secure into place using 5/8" draw pins and 1/8" spring pins.
- Check the brace alignment, then tighten the three bottom bolts and the brace bolt on each side to the torque specifications below. *Note:* be sure the radiator is still aligned properly, then loosed the top radiator mounts, this will allow you to shift the radiator for the next step.
- Go to the front of the bumper core and locate the front bumper access hole between the large plastic grids. They will be covered by black plastic. Cut the plastic away on each side to expose access holes in the front of the bumper. Take the mounting nuts off one side of the steel bumper core. Loosen the nuts on the other side. Pull the bumper core away from the car on one side to access the front of the frame. *Note:* do not remove the bumper entirely. The air bag sensors are attached to the rear of the bumper core and we want to leave them there undisturbed. Shift the radiator, if needed, to insert a 1/2" x 1 1/4" bolt through the remaining top hole in the brace. Follow with a 1/4" x 2" x 2" backing plate, lock washer and nut inserted through the front of the frame tube, then tighten to the torque specifications below. Check and make sure that nothing touches the side of the radiator.

BOLT TORQUE REQUIREMENTS

Note: The torque values represented below are intended as general guidelines. Torque requirements for specific applications may vary. Roadmaster does not warrant this information to be accurate for all applications and disclaims all liability for any claims or damages which may result from its use.

STANDARD BOLTS			METRIC BOLTS			METRIC BOLTS		
Thread Size	Grade	Torque	Thread Size	Grade	Plated/Unplated	Thread Size	Grade	Plated/Unplated
5/16	5	13 ft./lb.	8mm-1.0	8.8	20 ft./lb. 18 ft./lb.	12mm-1.25	8.8	70 ft./lb. 65 ft./lb.
3/8	5	23 ft./lb.	8mm-1.25	8.8	19 ft./lb. 18 ft./lb.	12mm-1.5	8.8	66 ft./lb. 61 ft./lb.
7/16	5	37 ft./lb.	10mm-1.25	8.8	38 ft./lb. 36 ft./lb.	12mm-1.75	8.8	65 ft./lb. 60 ft./lb.
1/2	5	56 ft./lb.	10mm-1.5	8.8	37 ft./lb. 35 ft./lb.	14mm-2.0	8.8	104 ft./lb. 97 ft./lb.
5/8	5	150 ft./lb.						

MOUNTING BRACKET KIT INSTALLATION INSTRUCTIONS

KIT NO. 175-17

8. Follow step seven for the remaining side, then replace the bumper tabs removed in a previous step.
9. Tighten the bumper core mounting nuts. Then, put 1/2" x 1 1/2" carriage bolts and 1/4" x 1 1/4" x 2" backing plates through the front bumper core mounting access holes and into two square holes located in the bottom of the bumper core. *Note:* if the car is an LS model, go to step 10, then come back and proceed with the following step. Bolt the 1/4" x 1 1/2" upper braces to the bottom of the bumper using 1/2" nuts and lock washers. Now, bolt the bumper braces to the lower receiver braces with 1/2" x 1 1/2" bolts, flat washers, lock washers and nuts.
10. Temporarily remove the front braces from the receivers and reinstall the bumper skin and all fasteners, including the lower air dam. Replace the top radiator plastic and the headlights. *Note:* if the car is an LS model, the lower air dam will have to be trimmed to fit the receiver braces. Also, two slots will have to be made in the lower bumper skin for the upper braces.
11. Reinstall the front braces and secure using the 5/8" draw pins and 1/8" spring pins. Mount the tow bar according to the manufacturers instructions and torque the bolts to the specifications below. Attach one end of the safety cables to the lower braces with the supplied cable connectors and the other end to the tow vehicle's safety cables.

HARDWARE LIST:

- 2-1/2" X 1 1/2" CARRIAGE BOLTS
- 2-1/2" X 1 1/4" BOLTS
- 2-1/2" X 1 1/2" BOLTS
- 2-1/2" FLAT WASHERS
- 6-1/2" LOCK WASHERS
- 6-1/2" NUTS
- 2-8MM X 1.25 X 40MM BOLTS
- 2-8MM FENDER WASHERS
- 2-8MM LOCK WASHERS
- 2-1/4" X 2" X 2" ROUND HOLE BACKING PLATES
- 2-1/4" X 1 1/4" X 2" SQ HOLE BACKING PLATES
- 2-5/8" DRAW PINS
- 2-1/8" SPRING PINS
- 2-CABLE CONNECTORS
- 2-10" CABLES
- 2-BUMPER BRACES

07-10-00

BOLT TORQUE REQUIREMENTS

Note: The torque values represented below are intended as general guidelines. Torque requirements for specific applications may vary. Roadmaster does not warrant this information to be accurate for all applications and disclaims all liability for any claims or damages which may result from its use.

STANDARD BOLTS			METRIC BOLTS			METRIC BOLTS		
Thread Size	Grade	Torque	Thread Size	Grade	Plated/Unplated	Thread Size	Grade	Plated/Unplated
5/16	5	13 ft./lb.	8mm-1.0	8.8	20 ft./lb. 18 ft./lb.	12mm-1.25	8.8	70 ft./lb. 65 ft./lb.
3/8	5	23 ft./lb.	8mm-1.25	8.8	19 ft./lb. 18 ft./lb.	12mm-1.5	8.8	66 ft./lb. 61 ft./lb.
7/16	5	37 ft./lb.	10mm-1.25	8.8	38 ft./lb. 36 ft./lb.	12mm-1.75	8.8	65 ft./lb. 60 ft./lb.
1/2	5	56 ft./lb.	10mm-1.5	8.8	37 ft./lb. 35 ft./lb.	14mm-2.0	8.8	104 ft./lb. 97 ft./lb.
5/8	5	150 ft./lb.						