

MOUNTING BRACKET KIT INSTALLATION INSTRUCTIONS

PARTS LIST:

- 1- MAIN BRACE (A) - Passenger side
- 1- MAIN BRACE (B) - Driver's side
- 1- FRONT BRACE (C) - Passenger side
- 1- FRONT BRACE (D) - Driver's side
- 1- CROSS BRACE (E)
- 1- SIDE BRACE (F) - Passenger side
- 1- SIDE BRACE (G) - Driver's side

KIT NO. 162-1

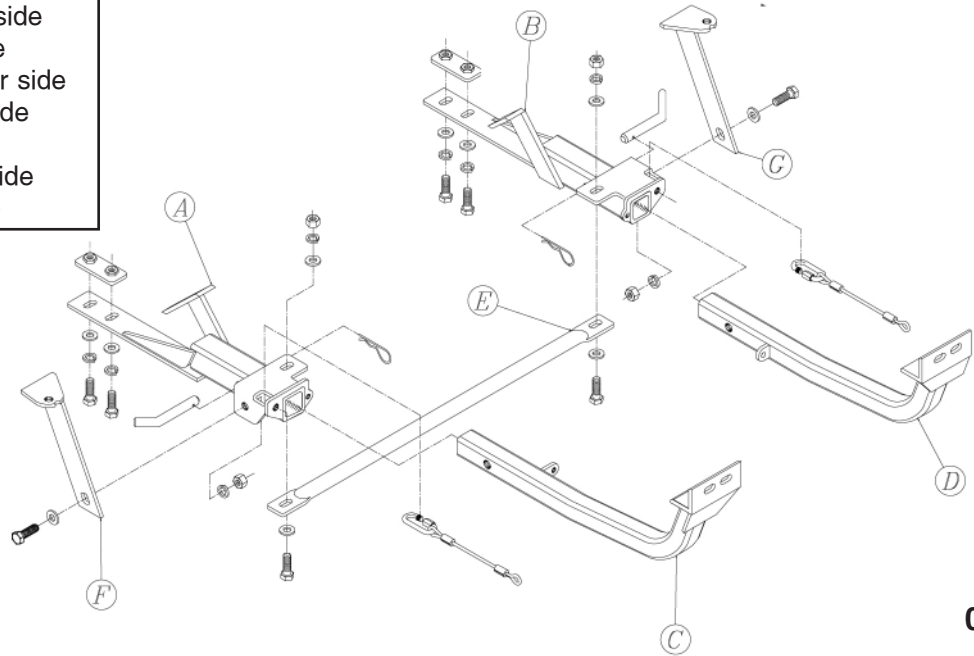

03-15-00

IMPORTANT: All brackets *must* be assembled with all the bolts left loose for final adjustment and positioning (before tightening) unless otherwise instructed. All bolts *must* be torqued for proper strength. If more than one bolt is used per fastening point, the diagram may only show one.

- Use flat washers over all slotted holes
- Use lock washers on all fasteners

ROADMASTER Limited Warranty, including One-Year Conditional Warranty Text and Product Registration Card, in Carton.

WARNING

Failure to follow these instructions can result in property damage, personal injury or even death.

- Installation of most mounting brackets requires moderate mechanical aptitude and skills. We strongly recommend professional installation by an experienced installer.
- The installer must read the instructions and use all bolts and parts supplied. Failure to do so could result in loss of the towed vehicle.
- Use Loctite® Red on all bolts used for mounting this bracket.
- Do not use this document for custom fabrication, as it may not show all parts or structural components. Custom fabrication or an attempt to copy this bracket design could result in loss of the towed vehicle.
- Every 3,000 miles, the owner must inspect the fasteners for proper torque, according to the bolt torque requirements chart on the last page of these instructions. The owner must also inspect all mounts and brackets for cracks or other signs of fatigue every 3,000 miles. Failure to do so could result in loss of the towed vehicle.
- The owner must check the vehicle manufacturer's instructions for the proper procedure(s) to prepare the vehicle for towing. Some vehicles must be equipped with a transmission lube pump, an axle disconnect, driveline disconnect or free-wheeling hubs before they can be towed. Failure to properly equip the vehicle will cause severe damage to the transmission.
- If running changes were made by the vehicle manufacturer after this bracket was designed, some bolts or other fasteners in the hardware pack may no longer be the correct size. It is the installer's responsibility to verify that the bracket is securely fastened to the vehicle and fitted with the correct hardware to account for these changes. Failure to securely

fasten the bracket could result in loss of the towed vehicle.

- If the towed vehicle has been in an accident, it must be properly repaired before attaching the bracket. Do not install the bracket if any structural frame damage is found. Failure to repair the damage could result in the loss of the towed vehicle.
- Some motorhome chassis have such a tight turning radius that you can damage your motorhome, towed vehicle, tow bar or bracket while turning sharply. Before getting on the road, test your turning radius in an empty parking lot. Turning too sharply could result in non-warranty damage to towing system, motorhome and/or towed vehicle.
- Do not back up with the towed vehicle attached or non-warranty damage will occur to your towing system, motorhome and/or towed vehicle.
- The safety cables must connect the towing vehicle to the towed vehicle frame to frame, with the cables crossed, with enough slack for sharp turns. Refer to the cable instructions for proper routing. Failure to leave enough slack in the safety cables, or failure to connect the safety cables frame to frame, will result in the loss of the towed vehicle.
- This bracket is designed for use with ROADMASTER tow bars and ROADMASTER adaptors only. Using this bracket with other brands, without an approved ROADMASTER adaptor, may result in non-warranty damage or injury.
- Upon final installation, the installer must inspect the bracket to ensure adequate clearance, particularly around hoses, air conditioner lines, radiators, etc., or non-warranty damage to the towed vehicle will result.
- This bracket is only warranted for the original installation. Installing a used bracket on another vehicle is not recommended and will void the warranty.

MOUNTING BRACKET KIT INSTALLATION INSTRUCTIONS

- Important:** please use all supplied bolts and parts and read all instructions carefully before beginning this installation. The majority of questions you may have can be answered within the text, and proper installation will ensure safe and secure travel. Now, begin the installation. This bracket assembly utilizes the lower frame, subframe, stabilizer bar mount as attachment points. Remove the lower plastic air dam located under the bumper. It will be necessary to trim and refit later. Work on one side at a time, starting with the passenger side.
- Remove the top stabilizer bar mounting bolts from the stabilizer mounting bracket. Hold the lower main brace in position with the rear mounting tab over the top of the stabilizer mounting bracket. Reinstall the stabilizer bar mounting bolt through the braces rear mounting tab.
- Now, find the large subframe mount bolt near the front and above the brace. Remove this bolt and reinstall through the side brace mounting tab. Be sure to install as illustrated. Bolt the side brace to the main brace using the supplied 1/2" x 1 1/2" bolts, flat washers, lock washers and nut.
- Locate the existing holes in the subframe that line up with the two holes in the rear lower brace extension. A 1/4" x 1 1/2" x 3 1/2" threaded backing plate will have to be fishwired through the hollow front of the subframe and lined up with the 1/2" holes in the brace extension. Once the backing plate is inserted it can be held in place with a finger through a nearby access hole in the sub frame. Bolt through the lower brace extension and subframe using the supplied 1/2" x 1 1/2" bolts, flat washers, and lock washers.
- Repeat steps 2, 3 and 4 to install the driver side lower and side brace with the following exception. After fishwiring the threaded backing plate into position and bolting through the one available hole in the subframe, swing the backing plate to one side for clearance and drill a 1/2" hole through the subframe using the existing hole in the lower brace extension as a template.
- Bolt the center brace between the lower braces using two 1/2" x 1 1/2" bolts, flat washers, lock washers and nuts.
- Align the lower braces so they are parallel and level with each other, then tighten all bolts to the torque specifications below.
- Insert the front tubular braces into the lower receiver tubes making sure that they are mated to the correct side. If correct the lock holes located on the receiver lip will match the front brace lock holes. Install the supplied 5/8" draw pins and 1/8" spring pins.
- Mount the tow bar according to the manufacturer's instructions. *Note:* the safety cables in the kit must be connected between the lower receiver and the vehicles tow bar. A recess is provided on the front of each receiver near the top for this. These cables are to be used in addition to the standard tow cables or chains between the tow vehicle and towed vehicle.

HARDWARE LIST:

- 8-1/2" X 1 1/2" BOLTS
- 8-1/2" LOCK WASHERS
- 10-1/2" FLAT WASHERS
- 4-1/2" NUTS
- 2-5/8" DRAW PINS
- 2-1/8" SPRING PINS
- 2-19" SAFETY CABLES
- 2-CABLE CONNECTORS
- 2-1/4" X 1 1/2" X 3 1/2" THREADED BACKING PLATES

03-15-00

BOLT TORQUE REQUIREMENTS

Note: The torque values represented below are intended as general guidelines. Torque requirements for specific applications may vary. Roadmaster does not warrant this information to be accurate for all applications and disclaims all liability for any claims or damages which may result from its use.

STANDARD BOLTS			METRIC BOLTS			METRIC BOLTS		
Thread Size	Grade	Torque	Thread Size	Grade	Plated / Unplated	Thread Size	Grade	Plated / Unplated
5/16.....	5.....	13 ft./lb.	8mm-1.0.....	8.8.....	20 ft./lb. 18 ft./lb.	12mm-1.25.....	8.8.....	70 ft./lb. 65 ft./lb.
3/8.....	5.....	23 ft./lb.	8mm-1.25.....	8.8.....	19 ft./lb. 18 ft./lb.	12mm-1.5.....	8.8.....	66 ft./lb. 61 ft./lb.
7/16.....	5.....	37 ft./lb.	10mm-1.25.....	8.8.....	38 ft./lb. 36 ft./lb.	12mm-1.75.....	8.8.....	65 ft./lb. 60 ft./lb.
1/2.....	5.....	56 ft./lb.	10mm-1.5.....	8.8.....	37 ft./lb. 35 ft./lb.	14mm-2.0.....	8.8.....	104 ft./lb. 97 ft./lb.
5/8.....	5.....	150 ft./lb.						

All illustrations and specifications contained herein are based on the latest information available at the time of publication approval. ROADMASTER, INC. reserves the right to make changes at any time without notice in material, specification and models or to discontinue models.