



Installation Instructions

Thank you for purchasing this anti-sway bar kit. Please read through these instructions before installation.

Front Anti-Sway Bar TruTrac Bar Combo Kit for Workhorse W16/18

part #1259-116
1-5/8" diameter

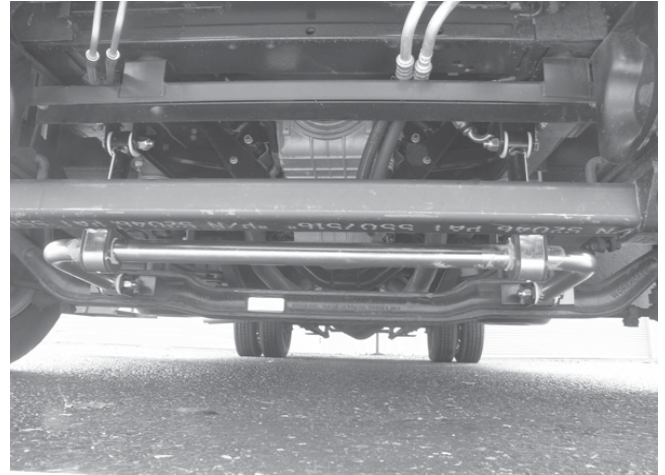

INTRODUCTION

Thank you for purchasing this anti-sway bar/trac bar combo kit. This kit is designed to improve the handling characteristics of your Workhorse by reducing the body roll and balancing the weight transfer during cornering. The anti-sway bar kit is engineered for long life and trouble-free performance. For maximum suspension control, use this kit along with our rear anti-sway bar kit.

All the hardware needed for installation is included in this kit. Refer to the PARTS LIST in these instructions to identify the parts.

SUGGESTED TOOLS

The following tools are suggested to complete the installation procedures:

- General hand tools
- 1/8", 1/2" drill bits
- 1/2" drill
- Torque wrench

WARNING

- If raising the vehicle to install the anti-sway bar, always support the vehicle with jack stands at both frame rails or at the rear axle before working underneath. Ensure that the jack stands are securely positioned, and are rated at or above the weight of the vehicle.
- The installer must read the instructions and use all bolts and parts supplied. Use only the parts supplied by ROADMASTER to install this kit.
- Minor modifications are sometimes necessary due to slight vehicle variations, even for the same year, make and model.
- If running changes were made by the manufacturer after this kit was designed, there may be weldments, braces, gussets, or other structural items which interfere with the installation. It is the installer's responsibility to allow for these running changes without sacrificing the structural integrity of the anti-sway bar. Failure to securely fasten the anti-sway bar could result in property damage,

personal injury or even death.

- ROADMASTER will not be responsible for any damage or injury resulting from any modification or alteration.
- Check ALL the fasteners for tightness before and after road testing the vehicle.
- Do not use this document for custom fabrication, as it may not show all parts or structural components.
- Do not use an air impact wrench when re-installing bolts, as stripped threads may result.
- This anti-sway bar is only warranted for the original installation. Installing a used anti-sway bar on another vehicle is not recommended and will void the warranty.

WARNING

Failure to follow these instructions can result in property damage, personal injury or even death.

PARTS LIST

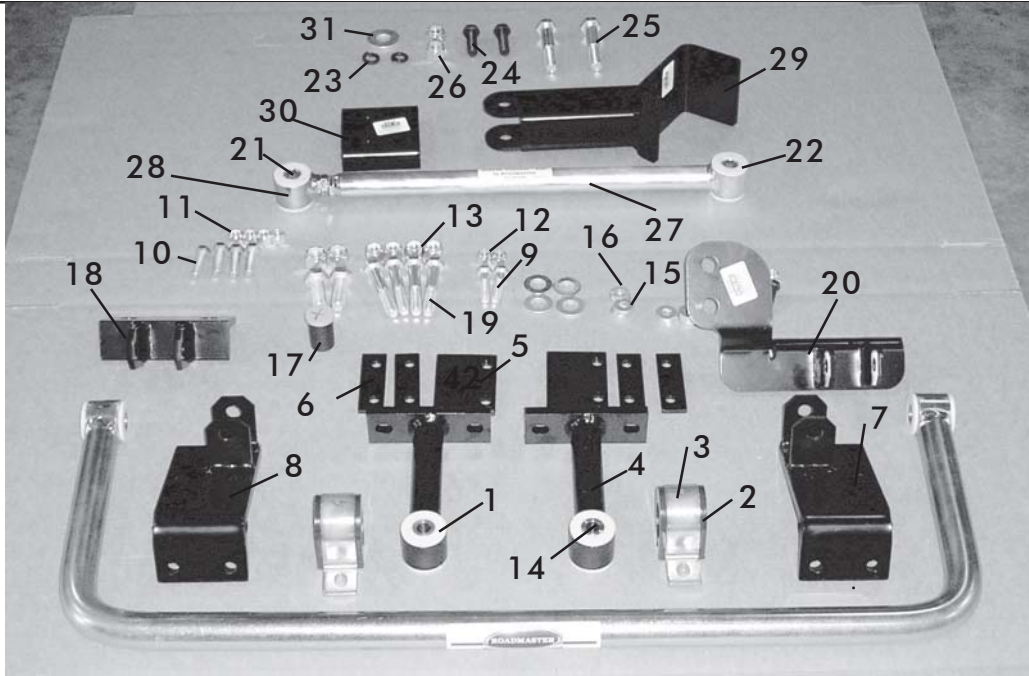

Part #1259-116

Part #	Description	Qty	Part #	Description	Qty
1	205209-00 Poly Bushing	8	18	B537 Bracket axle	1
2	205222-10 Poly Bushing	2	19	350163-00 5/8" Capscrew	4
3	B141 U-damp	2	20	B595 Bracket, combo axle	1
4	B414 Droplink W22, Front	2	21	205504-00 Sleeve	2
5	B419 Bracket Clamp W22	2	22	205209-00 Bushing	4
6	B423 Bracket Shim W22	2	23	350313-00 5/8" Lock Washer	1
7	B547 Bracket Frame Left	1	24	350452-00 5/8" Hex bolt	1
8	B548 Bracket frame right	1	25	350185-00 3/4" Capscrew	2
9	350097-00 Bolt, 1/2" x 2"	2	26	350265-00 3/4" Locknut	2
10	350076-80 Bolt, 7/16" x 2"	4	27	B531 Tube Panhard Tru Trac	1
11	350256-02 Locknut, 7/16"	4	28	B532 Rod End	1
12	350259-00 Nut, 1/2"	6	29	B528 Bracket Frame	1
13	350263-00 Locknut, 5/8"	4	30	B587 Frame Pinch Plate	1
14	205503-00 Sleeve	4	31	350314-00 3/4" Cut Washer	1
15	350304-80 Washer, 3/8"	8	32	350096-80* 1/2" x 1-3/4" NC GRD8	4
16	350308-20 Washer, 1/2"	12			
17	400011-30 Grease AQUALUBE	1			

* Not shown

INSTALLATION

The following instructions must be followed in the order listed to ensure a proper installation and to preserve the ROADMASTER warranty.

Anti-sway bar Installaion

1. Install the axle brackets.

Remove the the front U-bolt nuts on each side. Install B537 axle on the passenger side and install the B595 on the driver's side brackets and reinstall the nuts. Do not tighten at this time (Figure 1).

2. Install the driver's side frame bracket.

Locate the rear steering box bracket on the outside of the frame rail. The driver's side bracket (B547) will mount just behind the steering box bracket, toward the rear (Figure 2). Clamp the bracket into place and use the holes in the bracket as a template, mark the holes on the outside of the frame rail. Remove the bracket and drill two 1/2" holes through the frame (make sure to protect any lines or wires that may be inside the frame). Install the bracket using 1/2" x 1 1/2" bolts (350097-00) and secure with the washers and nuts. Torque to 80-100ft.-lbs.. Assemble the spacer plate and clamp plate as shown using 7/16" bolts, washers and nuts. Tighten the clamp bolts to 40-50ft.-lbs. (Figure 3).

3. Install the passenger side frame bracket.

The passenger side frame bracket is located directly opposite of the driver's side. Clamp in place, mark the holes and repeat step 2 for the passenger side.

4. Mount the bar.

Attach the anti-sway bar to the axle plates using 5/8" bolts (350163-00). Tighten to 30-45 ft.-lbs.(Figure 4).

5. Assemble and connect the drop links.

Install the bushings (205209-00) and sleeves (205503-00) into the drop links. Attach to frame brackets on each side. Tighten to 30-45 ft.-lbs.(Figure 5).

6. Connect the anti-sway bar to the drop links.

Lubricate the inside of anti-sway bar bushings with the provided grease (Figure 6)). Install sway bar bushings and U-clamps on the bar. Connect the anti-sway bar to the drop links using the bolts (350096-80) provided. Torque to 60-75 ft.-lbs.(Figure 5).

7. Tighten remaining fasteners.

Tighten axle clamps to factory specs.

Figure 1



Figure 2



Figure 3

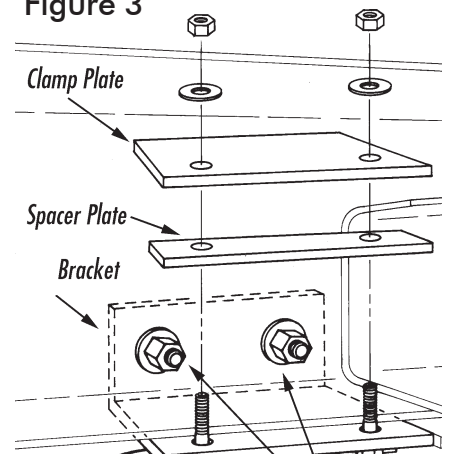

Figure 4



Figure 5



Figure 6

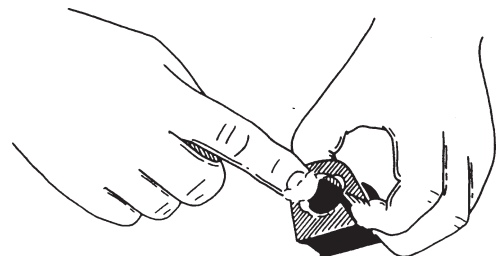

INSTALLATION

TruTrac bar Installaion

8. Under normal circumstances, this installation will take 30-40 minutes. Before starting the installation, prepare the motorhome by parking it on a level surface and not on jacks.
9. Begin by removing the nuts on the front u-bolt on the driver's side of the front axle. Place the axle bracket on the u-bolt as in Figure 1, and replace and torque the nuts that were previously removed to 140-150 ft.-lbs.
10. On W16 and W18 models, remove the factory bolt attached to the cross member. Then, place the frame bracket on the frame and reattach the factory bolt. Now place the large frame bracket on the outside of the passenger side frame rail in front of the axle, and loosely secure it with the inner bracket and supplied bolts (Figure 2). *Note:* the W16 and the W18 models only use the 1/2" inner bracket. Do not tighten the mounting bolts at this time. Place the adjustable bar with the stationary end in the frame bracket and insert the bolt from the rear. Adjust the length of the bar so that you can put the adjustable end of the bar into the axle bracket, but do not insert the bolt. At this point, make sure the bar slides freely in the axle bracket. If it doesn't, slide the frame bracket forward or back until it does. When the bar easily fits in the axle bracket, tighten the frame bracket mounting bolts.
11. Now, insert the end bolts from the rear. Make sure both end bolts face toward the front of the coach w/nuts on the front side of the bar. Adjust the bar until both end bolts easily slide through the bracket and the bar. Tighten both end bolts. These bolts are to be tightened only enough so that the bolts are snug in the bracket, but do not put pressure on the ends of the bar. The last step is to tighten the jam nut on the bar.
12. Check to make sure that no wires, hoses, or lines are being obstructed. The installation is now complete, and should look like Figure 3.
13. Road test and re-check installation. Recheck all nuts and bolts for tightness. After the first 1,000 miles or so, check to make sure nuts and bolts have not loosened.

Figure 1



Figure 2



Figure 3

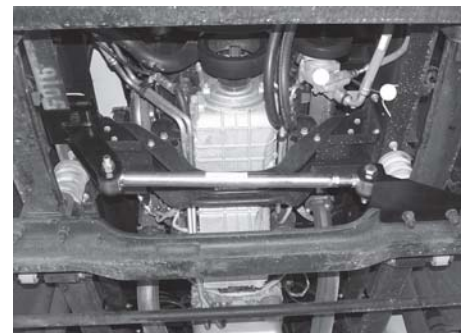

INSTALLATION

WARNING

After road testing, re-check all fasteners for proper tightness — if a fastener has worked loose or fallen off, re-tighten or replace it. Without all kit components properly tightened or in place, the anti-sway bar will not stabilize the vehicle at full capacity, which may cause reduced cornering ability or other reductions in vehicle handling or performance.

Failure to follow these instructions may result in property damage, personal injury or even death.

WARNING

The anti-sway bar/TruTrac bar is not a load-bearing component

Do not tow or hoist the vehicle using the sway bar or its mounting brackets as attachment points. The anti-sway bar is not designed to carry the weight of the vehicle and may collapse, which will damage the sway bar components, the suspension, or other components. The vehicle will detach or fall, which may cause severe personal injury.

Free Extended Warranty

*You must accurately and completely fill out and mail the product registration card within thirty (30) days from the date of purchase to qualify for your warranty. **If we receive your card, completely and accurately filled out, within twenty (20) days from the date of purchase, we will extend the coverage to a total of two (2) years at no extra charge.***

Your product registration is an important record for ROADMASTER to keep in touch with you. It also enables us to expedite any future claim, update or recall that may arise concerning our products.

LIMITED WARRANTY

1. WARRANTY

1a. WARRANTY OF CONFORMITY AT TIME OF SALE

ROADMASTER, Inc. warrants that at the time of sale of this product it will be free from defects in material and manufacture and will conform to ROADMASTER'S specifications for the product.

1b. CONDITIONAL ONE-YEAR WARRANTY

In addition to the preceding time-of-sale warranty, if the product registration card is completely and accurately filled out and mailed to ROADMASTER within thirty (30) days of purchase, ROADMASTER will provide an additional warranty that for a period of one year after sale the product will remain in good working order, PROVIDED THAT the product is installed and maintained in accordance with ROADMASTER'S instructions and is not subjected to: (a) alteration or unauthorized repairs or repairs by anyone other than ROADMASTER or a ROADMASTER-authorized service center, (b) misuse, abuse, commercial use, or improper maintenance, (c) Acts of God (including without limitation hurricanes, tornadoes, floods, or other severe weather or natural phenomena), (d) failures due to products not supplied by ROADMASTER, or (e) other treatments, uses, or installations for which the product was not intended. This warranty extends only to the first retail purchaser-consumer of the product and is not transferable.

EXTENDED WARRANTY PERIOD: If ROADMASTER receives the product registration card, completely and accurately filled out, within twenty (20) days of purchase, ROADMASTER will enlarge the one-year warranty period in the preceding paragraph to a period of two years.

2. DISCLAIMER OF OTHER WARRANTIES

The preceding warranties are the exclusive and sole express warranties given by ROADMASTER. They supersede any prior, contrary or additional representations, whether oral or written. No agent, representative, dealer or employee has the authority to alter or increase the obligations or limitations of this warranty. Any implied warranties, including the WARRANTY OF MERCHANTABILITY and any WARRANTY OF FITNESS FOR A PARTICULAR PURPOSE, are limited in duration to thirty days or the term of the applicable express warranty provided above, whichever is longer.

Some states do not allow limitations on how long an implied warranty lasts, so the above limitation may not apply to you.

3. EXCLUSIVE REMEDY FOR ANY NONCONFORMITIES

If during the applicable Warranty Period, the product does not conform to the preceding Warranties, notify ROADMASTER as provided below, and within a reasonable time ROADMASTER will provide, at its option, one of the following: (1) replacement components for any nonconforming or defective product or components or (2) the percentage of the purchase price for the nonconforming product equal to the percentage of the Warranty Period remaining when ROADMASTER is notified of the nonconformity. ROADMASTER will, at its option, (a) use new and/or reconditioned parts in performing warranty repairs and making replacement products, (b) use parts or products of original or improved design in the repair or replacement. If ROADMASTER repairs or replaces a product, its warranty continues for the remaining portion of the original Warranty Period or 60 days from the date of the return shipment to the customer, whichever is greater. All replaced products and all parts removed from repaired products become the property of ROADMASTER. ROADMASTER will not provide, and will not be liable for, labor, costs of removal or reinstallation of components, disposal, shipping, freight, taxes, or other incidental charges.

THESE REMEDIES ARE THE EXCLUSIVE AND SOLE REMEDIES FOR ANY BREACH OF WARRANTY.

The date of purchase must coincide with the original warranty registration card on file. ROADMASTER will authorize (a) shipment of the product to ROADMASTER or (b) repair or replacement at the nearest warranty service center—in both cases with shipping at your expense. Do not purchase replacement parts or pay for repair labor—you will not be reimbursed. Compliance with the requirements of this paragraph is a condition to coverage under the Warranty: if these requirements are not complied with, ROADMASTER will have no obligation to provide any remedy for any breach of warranty.

4. DISCLAIMER OF INCIDENTAL AND CONSEQUENTIAL DAMAGES

IN NO EVENT SHALL ROADMASTER BE LIABLE FOR ANY INCIDENTAL, SPECIAL, INDIRECT OR CONSEQUENTIAL DAMAGES, WHETHER RESULTING FROM NONDELIVERY OR FROM THE USE, MISUSE OR INABILITY TO USE THE PRODUCT OR FROM DEFECTS IN THE PRODUCT.

Some states do not allow the exclusion or limitation of incidental or consequential damages, so the above limitation may not apply to you.

5. APPLICABLE LAW

This Warranty will be interpreted, construed, and enforced in all respects in accordance with the laws of the State of Washington, without reference to its choice of law rules. The U.N. Convention on Contracts for the International Sale of Goods will not apply to this Warranty.

6. SEVERABILITY

If any provision of this warranty is found to be invalid or unenforceable, then the remainder shall have full force and effect, and the invalid provision shall be partially enforced to the maximum extent permitted by law to effectuate the purpose of the agreement.