

# MOUNTING BRACKET KIT

## INSTALLATION INSTRUCTIONS

**PARTS LIST:**

- 1- MAIN BRACE (A) - Passenger side
- 1- MAIN BRACE (B) - Driver's side
- 1- FRONT BRACE (C) - Driver's side
- 1- FRONT BRACE (D) - Passenger side

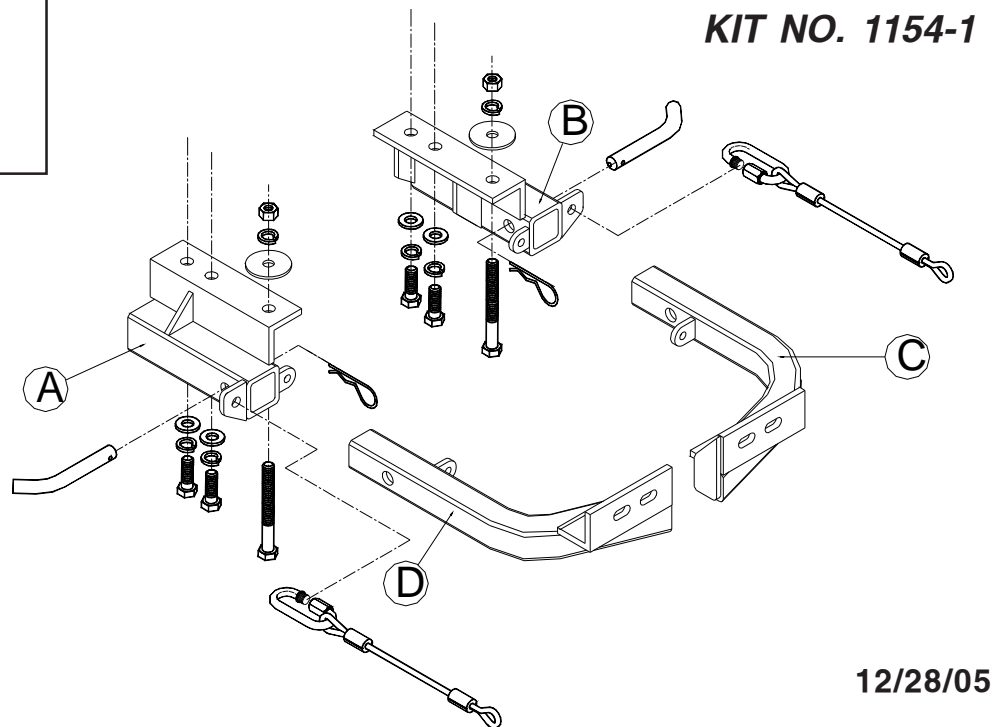

12/28/05

**IMPORTANT:** All brackets *must* be assembled with all the bolts left loose for final adjustment and positioning (before tightening) unless otherwise instructed. All bolts *must* be torqued for proper strength. If more than one bolt is used per fastening point, the diagram may only show one.

- Use flat washers over all slotted holes
- Use lock washers on all fasteners

ROADMASTER Limited Warranty, including One-Year Conditional Warranty Text and Product Registration Card, in Carton.

### **WARNING**

Failure to follow these instructions can result in property damage, personal injury or even death.

- Installation of most mounting brackets requires moderate mechanical aptitude and skills. We strongly recommend professional installation by an experienced installer.
- The installer must read the instructions and use all bolts and parts supplied. Failure to do so could result in loss of the towed vehicle.
- Use Loctite® Red on all bolts used for mounting this bracket.
- Do not use this document for custom fabrication, as it may not show all parts or structural components. Custom fabrication or an attempt to copy this bracket design could result in loss of the towed vehicle.
- Every 3,000 miles, the owner must inspect the fasteners for proper torque, according to the bolt torque requirements chart on the last page of these instructions. The owner must also inspect all mounts and brackets for cracks or other signs of fatigue every 3,000 miles. Failure to do so could result in loss of the towed vehicle.
- The owner must check the vehicle manufacturer's instructions for the proper procedure(s) to prepare the vehicle for towing. Some vehicles must be equipped with a transmission lube pump, an axle disconnect, driveline disconnect or free-wheeling hubs before they can be towed. Failure to properly equip the vehicle will cause severe damage to the transmission.
- If running changes were made by the vehicle manufacturer after this bracket was designed, some bolts or other fasteners in the hardware pack may no longer be the correct size. It is the installer's responsibility to verify that the bracket is securely fastened to the vehicle and fitted with the correct hardware to account for these changes. Failure to securely fasten the bracket could result in loss of the towed vehicle.
- If the towed vehicle has been in an accident, it must be properly repaired before attaching the bracket. Do not install the bracket if any structural frame damage is found. Failure to repair the damage could result in the loss of the towed vehicle.
- Some motorhome chassis have such a tight turning radius that you can damage your motorhome, towed vehicle, tow bar or bracket while turning sharply. Before getting on the road, test your turning radius in an empty parking lot. Turning too sharply could result in non-warranty damage to towing system, motorhome and/or towed vehicle.
- Do not back up with the towed vehicle attached or non-warranty damage will occur to your towing system, motorhome and/or towed vehicle.
- The safety cables must connect the towing vehicle to the towed vehicle frame to frame, with the cables crossed, with enough slack for sharp turns. Refer to the cable instructions for proper routing. Failure to leave enough slack in the safety cables, or failure to connect the safety cables frame to frame, will result in the loss of the towed vehicle.
- This bracket is designed for use with ROADMASTER tow bars and ROADMASTER adaptors only. Using this bracket with other brands, without an approved ROADMASTER adaptor, may result in non-warranty damage or injury.
- Upon final installation, the installer must inspect the bracket to ensure adequate clearance, particularly around hoses, air conditioner lines, radiators, etc., or non-warranty damage to the towed vehicle will result.
- This bracket is only warranted for the original installation. Installing a used bracket on another vehicle is not recommended and will void the warranty.

# MOUNTING BRACKET KIT INSTALLATION INSTRUCTIONS

**KIT NO. 1154-1**

1. **Important: please use all supplied bolts and parts and read all instructions carefully before beginning this installation. The majority of questions you may have can be answered within the text, and proper installation will ensure safe and secure travel.** Now, begin the installation. This bracket is one of our XL Series, which is partly removable. The main receiver brace attaches to the bottom of the front subframe. The bracket kit consists of two main receiver braces two front braces and the hardware kit. Remove the tow hooks and mounting bolts.
2. Hold a receiver brace to the bottom of the frame rail and bolt into position with two supplied 12mm x 1.25 x 40mm bolts, lock washers and fender washers. The front bolt also secures a plastic bumper tab, leave the plastic tab free, bolt through the front mounting hole\* and frame with 1/2" x 4 1/2" bolt, plate washers, lock washers and nuts. *Note:* some later models may require 1/2" x 5 1/2" bolts instead.
3. Repeat step 2 for the remaining side.  
**Note: for 2004/05/06 models** – 2004/05/06 models of this vehicles do not have an existing front mounting hole in the frame. For 2004/05/06 models, follow the procedure below to install the bracket:
  - a. Remove the tow hooks.
  - b. Bolt the main brace in place, using the two supplied 12mm x 1.25" x 40mm bolts, lock washers and nuts.
  - c. Using the front hole in the brace as a template, drill a 1/2" hole through the bottom and the top of the frame rail.
  - d. Bolt through the main brace and the frame rail, using a 1/2" x 5 1/2" bolt, plate washer, lock washer and nut. Repeat steps a, b and c on the remaining side.
4. Insert the front braces into the receiver braces and secure with 5/8" draw pins and 1/8" spring pins.
5. Mount the tow bar according to the manufacturer's instructions.
6. Attach the included 10" safety cables to the front of the receiver braces with the included cable connectors. Attach the other ends to the tow vehicle's safety cables and the tow bar.

**HARDWARE LIST:**

- 4-12MM X 1.25 X 40MM BOLTS
- 4-12MM LOCK WASHERS
- 4-12MM FENDER WASHERS
- 2- 1/2" X 4 1/2" BOLTS
- 2- 1/2" X 5 1/2" BOLTS
- 2- 1/2" LOCK WASHERS
- 2- 1/2" NUTS
- 2- 1/2" PLATE WASHERS
- 2-5/8" DRAW PINS
- 2-1/8" SPRING PINS
- 2-10" SAFETY CABLES, 8,000 lb. rated
- 2-CABLE CONNECTORS

**12/28/05**  
RV

### BOLT TORQUE REQUIREMENTS

Note: The torque values represented below are intended as general guidelines. Torque requirements for specific applications may vary. Roadmaster does not warrant this information to be accurate for all applications and disclaims all liability for any claims or damages which may result from its use.

STANDARD BOLTS			METRIC BOLTS			METRIC BOLTS		
Thread Size	Grade	Torque	Thread Size	Grade	Plated/Unplated	Thread Size	Grade	Plated/Unplated
5/16	5	13 ft./lb.	8mm-1.0	8.8	20 ft./lb. 18 ft./lb.	12mm-1.25	8.8	70 ft./lb. 65 ft./lb.
3/8	5	23 ft./lb.	8mm-1.25	8.8	19 ft./lb. 18 ft./lb.	12mm-1.5	8.8	66 ft./lb. 61 ft./lb.
7/16	5	37 ft./lb.	10mm-1.25	8.8	38 ft./lb. 36 ft./lb.	12mm-1.75	8.8	65 ft./lb. 60 ft./lb.
1/2	5	56 ft./lb.	10mm-1.5	8.8	37 ft./lb. 35 ft./lb.	14mm-2.0	8.8	104 ft./lb. 97 ft./lb.
5/8	5	150 ft./lb.						

All illustrations and specifications contained herein are based on the latest information available at the time of publication approval. ROADMASTER, INC. reserves the right to make changes at any time without notice in material, specification and models or to discontinue models.