

MOUNTING BRACKET KIT

INSTALLATION INSTRUCTIONS

PARTS LIST:

- 1- MAIN BRACE (A) - Passenger side
1- MAIN BRACE (B) - Driver's side

KIT NO.107-1

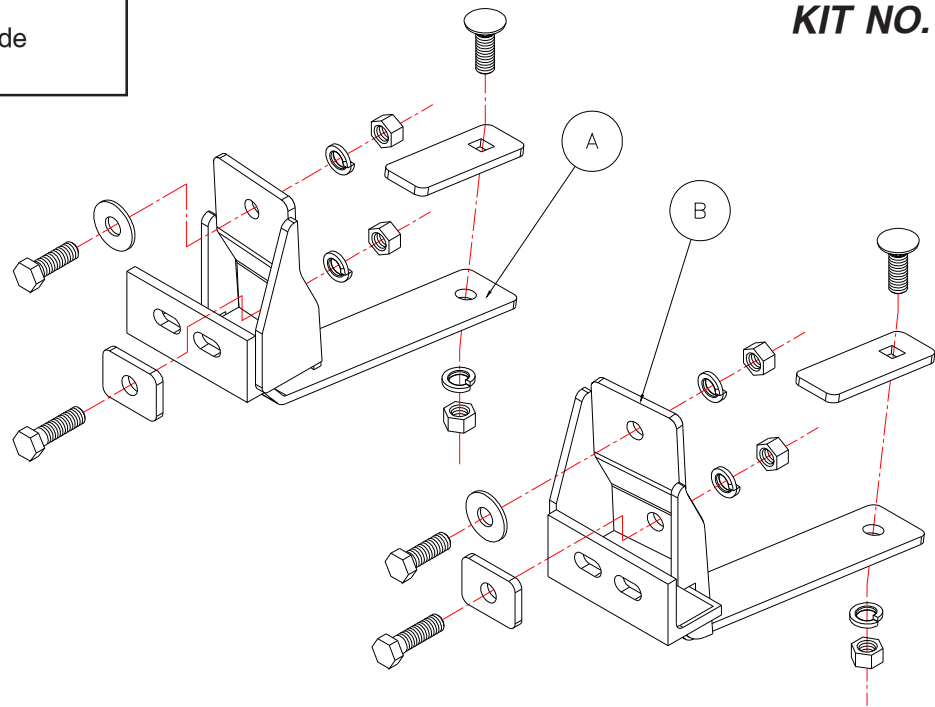

3-7-01

IMPORTANT: All brackets **must** be assembled with all the bolts left loose for final adjustment and positioning (before tightening) unless otherwise instructed. All bolts **must** be torqued for proper strength. If more than one bolt is used per fastening point, the diagram may only show one.

- Use flat washers over all slotted holes
- Use lock washers on all fasteners

ROADMASTER Limited Warranty, including One-Year Conditional Warranty Text and Product Registration Card, in Carton.

WARNING

Failure to follow these instructions can result in property damage, personal injury or even death.

- Installation of most mounting brackets requires moderate mechanical aptitude and skills. We strongly recommend professional installation by an experienced installer.
- The installer must read the instructions and use all bolts and parts supplied. Failure to do so could result in loss of the towed vehicle.
- Use Loctite® Red on all bolts used for mounting this bracket.
- Do not use this document for custom fabrication, as it may not show all parts or structural components. Custom fabrication or an attempt to copy this bracket design could result in loss of the towed vehicle.
- Every 3,000 miles, the owner must inspect the fasteners for proper torque, according to the bolt torque requirements chart on the last page of these instructions. The owner must also inspect all mounts and brackets for cracks or other signs of fatigue every 3,000 miles. Failure to do so could result in loss of the towed vehicle.
- The owner must check the vehicle manufacturer's instructions for the proper procedure(s) to prepare the vehicle for towing. Some vehicles must be equipped with a transmission lube pump, an axle disconnect, driveline disconnect or free-wheeling hubs before they can be towed. Failure to properly equip the vehicle will cause severe damage to the transmission.
- If running changes were made by the vehicle manufacturer after this bracket was designed, some bolts or other fasteners in the hardware pack may no longer be the correct size. It is the installer's responsibility to verify that the bracket is securely fastened to the vehicle and fitted with the correct hardware to account for these changes. Failure to securely

fasten the bracket could result in loss of the towed vehicle.

- If the towed vehicle has been in an accident, it must be properly repaired before attaching the bracket. **Do not install the bracket if any structural frame damage is found.** Failure to repair the damage could result in the loss of the towed vehicle.
- Some motorhome chassis have such a tight turning radius that you can damage your motorhome, towed vehicle, tow bar or bracket while turning sharply. **Before getting on the road, test your turning radius in an empty parking lot.** Turning too sharply could result in non-warranty damage to towing system, motorhome and/or towed vehicle.
- Do not back up with the towed vehicle attached or non-warranty damage will occur to your towing system, motorhome and/or towed vehicle.
- The safety cables must connect the towing vehicle to the towed vehicle frame to frame, with the cables crossed, with enough slack for sharp turns. Refer to the cable instructions for proper routing. Failure to leave enough slack in the safety cables, or failure to connect the safety cables frame to frame, will result in the loss of the towed vehicle.
- This bracket is designed for use with ROADMASTER tow bars and ROADMASTER adaptors only. **Using this bracket with other brands, without an approved ROADMASTER adaptor, may result in non-warranty damage or injury.**
- Upon final installation, the installer must inspect the bracket to ensure adequate clearance, particularly around hoses, air conditioner lines, radiators, etc., or non-warranty damage to the towed vehicle will result.
- This bracket is only warranted for the original installation. Installing a used bracket on another vehicle is not recommended and will void the warranty.

MOUNTING BRACKET KIT INSTALLATION INSTRUCTIONS

KIT NO. 107-1

- Important:** please use all supplied bolts and parts and read all instructions carefully before beginning this installation. The majority of questions you may have can be answered within the text, and proper installation will ensure safe and secure travel. Now, begin the installation. This bracket kit utilizes the existing front bumper mounting holes and the lower frame as attachment points. *Note:* if the front bumper has plastic molding it will have to be cut to fit around the braces or the braces can be slipped underneath the molding. Work on one side at a time to preserve bumper hole alignment.
- Working on one side at a time, remove the lower bumper mount bolt located in the face of the bumper(chrome carriage bolt) and with a 1/2" drill, enlarge the hole to 1/2". Insert a 1/2" x 1 3/4" bolt into this hole with a 1/4" x 1 1/2" x 2" backing plate and a nut on the back side. This will temporarily maintain bumper alignment.
- Holding the respective bracket into place, trim the lower plastic spoiler enough to allow the rear extension of the bracket to go back and contact the bottom of the frame. Remove the bracket and access the upper carriage bolt. Remove this bolt and drill this hole out to 1/2". Remove the 1/2" bolt temporarily installed in step 2 and mount the bracket directly to the face of the bumper. Bolt through the bracket, bumper and frame horn with the 1/2"x 1 1/2" bolt provided with a flat washer, lock washer and nut.
- Follow the same procedure for the remaining side. Align the brackets so that they are straight across and there is a distance of 27" and 30" between the holes in the face of the brackets. Using the bracket as a template, drill a 1/2" hole through the rear extension and up into the bottom of the frame. Fish wire a 1/2" x 1 1/2" carriage bolt and 1/4" x 1 1/2" x 4" backing plate through the opening in the end of the frame and down through the hole just drilled. Install a 1/2" lock washer and nut, then torque all bolts to the specifications below.
- Mount the tow bar according to manufacturer's instructions.

Hardware list

- 2- 1/2" x 1-1/2" bolts
- 2- 1/2" x 1-3/4" bolts
- 2- 1/2" x 1-1/2" carriage bolts
- 6- 1/2" nuts
- 6- 1/2" lock washers
- 2- 1/2" flat washers
- 2- 1/4" x 1-1/2" x 4" backing plates
- 2- 1/4" x 1-1/2" x 2" backing plates

3-7-01

BOLT TORQUE REQUIREMENTS

Note: The torque values represented below are intended as general guidelines. Torque requirements for specific applications may vary. Roadmaster does not warrant this information to be accurate for all applications and disclaims all liability for any claims or damages which may result from its use.

STANDARD BOLTS			METRIC BOLTS			METRIC BOLTS		
Thread Size	Grade	Torque	Thread Size	Grade	Plated/Unplated	Thread Size	Grade	Plated/Unplated
5/16	5	13 ft./lb.	8mm-1.0	8.8	20 ft./lb. 18 ft./lb.	12mm-1.25	8.8	70 ft./lb. 65 ft./lb.
3/8	5	23 ft./lb.	8mm-1.25	8.8	19 ft./lb. 18 ft./lb.	12mm-1.5	8.8	66 ft./lb. 61 ft./lb.
7/16	5	37 ft./lb.	10mm-1.25	8.8	38 ft./lb. 36 ft./lb.	12mm-1.75	8.8	65 ft./lb. 60 ft./lb.
1/2	5	56 ft./lb.	10mm-1.5	8.8	37 ft./lb. 35 ft./lb.	14mm-2.0	8.8	104 ft./lb. 97 ft./lb.
5/8	5	150 ft./lb.						

All illustrations and specifications contained herein are based on the latest information available at the time of publication approval. ROADMASTER, INC. reserves the right to make changes at any time without notice in material, specification and models or to discontinue models.