



INSTALL INSTRUCTIONS

Vaquero Front Bumper

Product : 410VF6B

Application : 2010+ RAM 2500,3500

⚠ WARNING

Read the instructions completely before beginning installation. Before tightening bolts, drilling or cutting where required, check to make sure there are no obstructions such as brake, fuel or electrical lines which may be damaged. Also keep in mind this is an after-market product and MAY require minor shimming and/or trimming, reaming, etc. for proper fit. Road Armor is not responsible for any damages to vehicle.

ⓘ IMPORTANT NOTICE

- Be sure to inspect and test fit your product to ensure proper fitment before having it coated, painted, bed lined, etc.
- Road Armor will not be responsible for the cost of coating your unit if any problems with fit or finish are not noted and addressed beforehand.

SAFETY FIRST!

- FOLLOW ALL INSTRUCTIONS, YOUR SAFETY AND THE SAFETY OF OTHERS IS MOST IMPORTANT.
- WEAR APPROPRIATE EYE PROTECTION AND EXERCISE CAUTION WHEN DRILLING / CUTTING

REQUIRED TOOLS

SAE & METRIC Socket set and wrenches

Screw drivers, pry tool, pick tool, pliers

RECOMMENDED TOOLS

Adjustable Table Cart / Table/Pallet Lift or Hoist

Impact driver

INCLUDED HARDWARE

- 8 1/2-13 Bolt Tabs Long (2-inch)
- 8 1/2-13 Bolt Tabs Short (1.5-inch)
- 2 1/2 x 3.75" Grade 8 Bolts
- 12 1/2" Washers
- 18 1/2" Lock Washers
- 8 1/2" Narrow Washers (1" OD)
- 18 1/2" Nuts
- 4 3/8-16 x 1" bolt
- 8 3/8 Washers
- 4 3/8 Lock Washers & Nuts
- 6 Dome Plugs (for non-sensor equipped trucks)

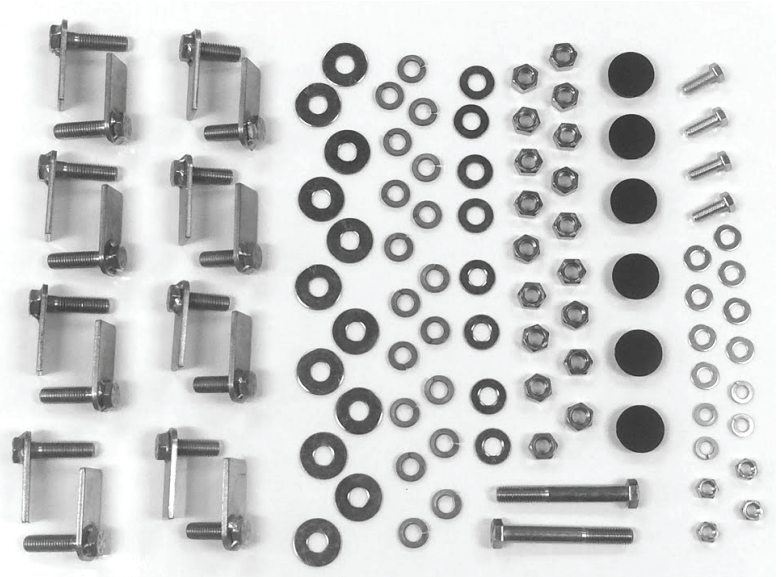

- 1 Remove (4) plastic ribbed retainer clips from "heavy duty" dust shield
- 2 Remove (4) grill support bolts and remove grill pulling away sides and bottom
- 3 Disconnect bumper harness plug, located near driver side fog light

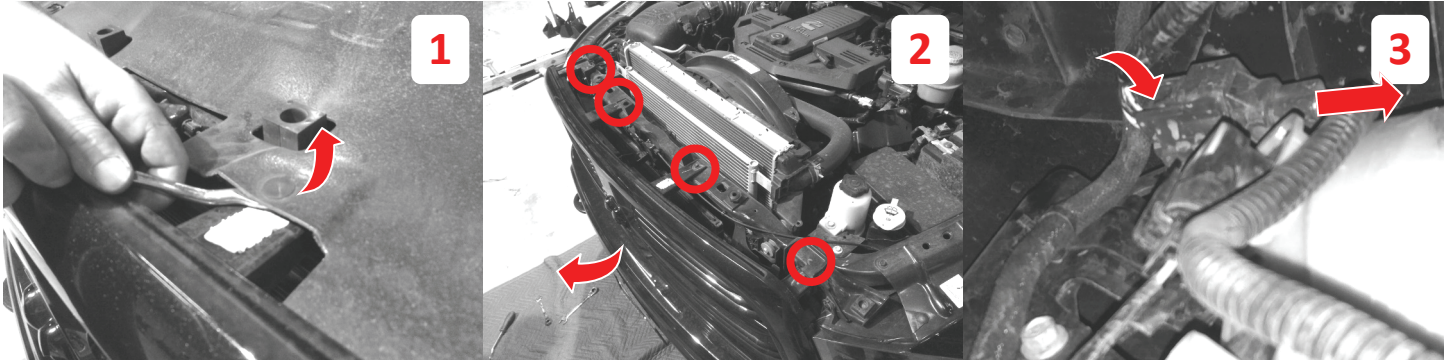

- 4 Remove (4) nuts from behind bumper each side located top and bottom of tow hooks. The top inside nut is accessed from the grill opening
- 5 Remove air dam over intercooler (if equipped) and factory tow hooks (set aside)
- 6 Remove OE bumper bracket and under-run guard and set aside hardware.

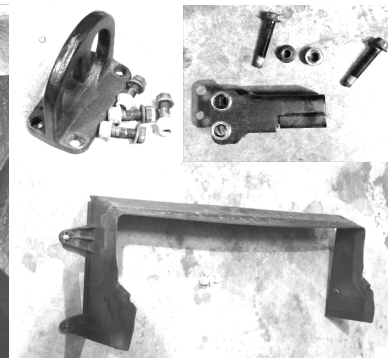
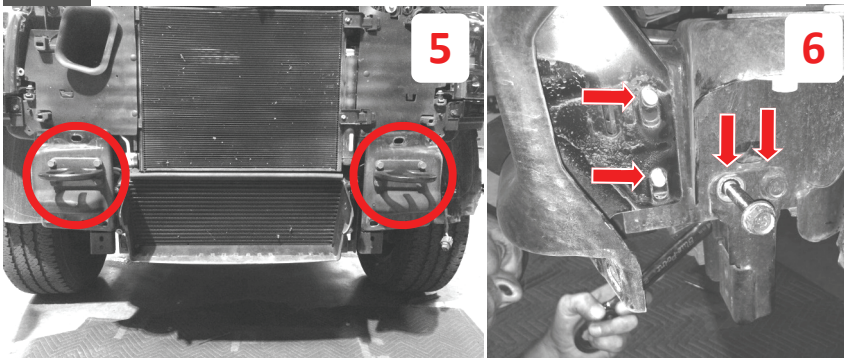
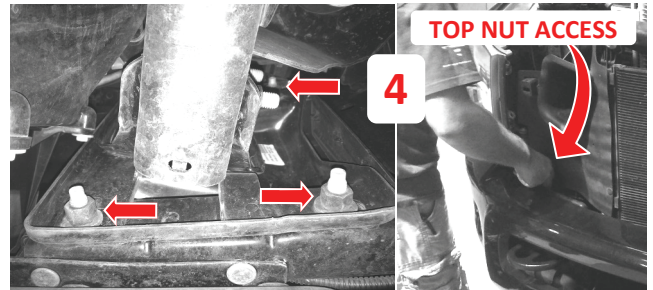

NOTICE

THE FOLLOW APPLY ONLY TO DIESEL TRUCKS. SKIP AHEAD NOW IF YOU HAVE A GASSER.

DIESEL MODELS ONLY BELOW

- A Remove intercooler brackets both sides (3 bolts each) top bolt access from above
- B Once removed push the intercooler down and away to remove double nut plates one side at a time. The driver side is more difficult and requires patience and persistence. Then re-install intercooler supports.

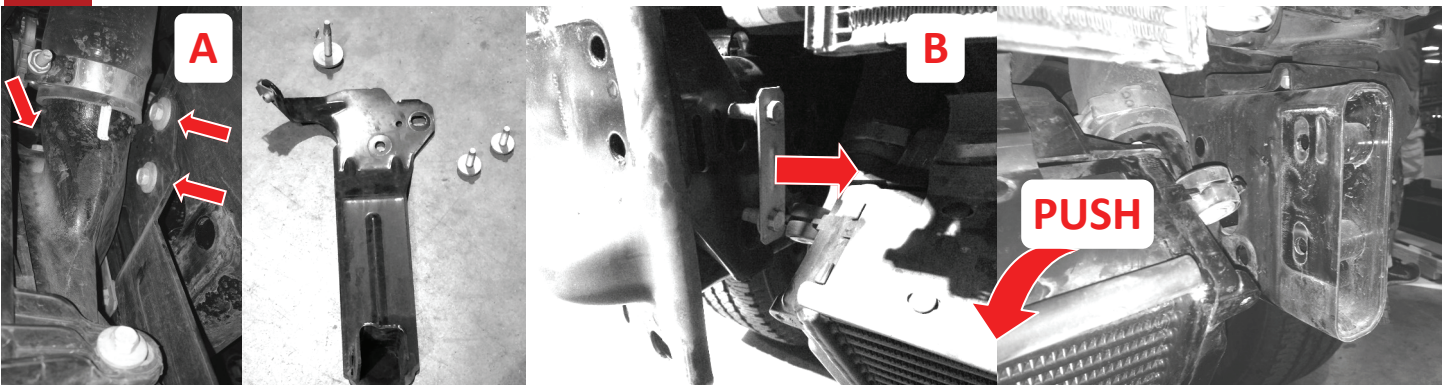

- 7 Reinstall intercooler air dam (if equipped)
- 8 Install Vaquero brackets as shown with long end on the inside of the frame re-using OE hardware. If the winch plate is going to be used, drill through the frame where indicated by the triangle and install 3.75" bolts.
- 9 Remove factory proximity sensors if equipped, taking care to reinstall them into Vaquero bumper in the same order they were removed.

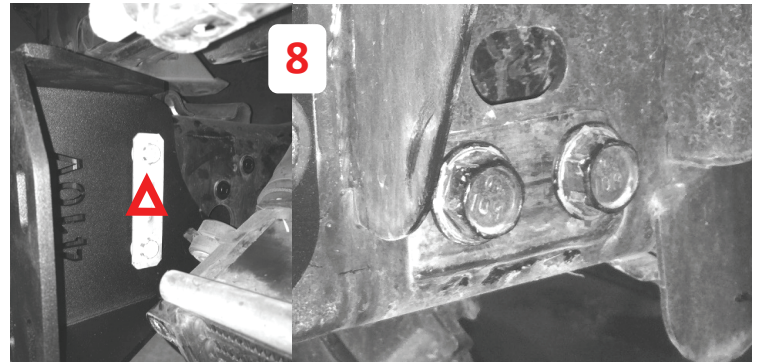

! **NOTICE** : while sensors are disconnected do not cycle the key or sensors may need to be reprogrammed by the dealership.

- 10 Disconnect and remove fog lights then re-install them into Vaquero bumper as shown. Using a pick tool, pry the tabs out to secure the light in place. ◆ Alternatively, an LED cube will mount with the post back.

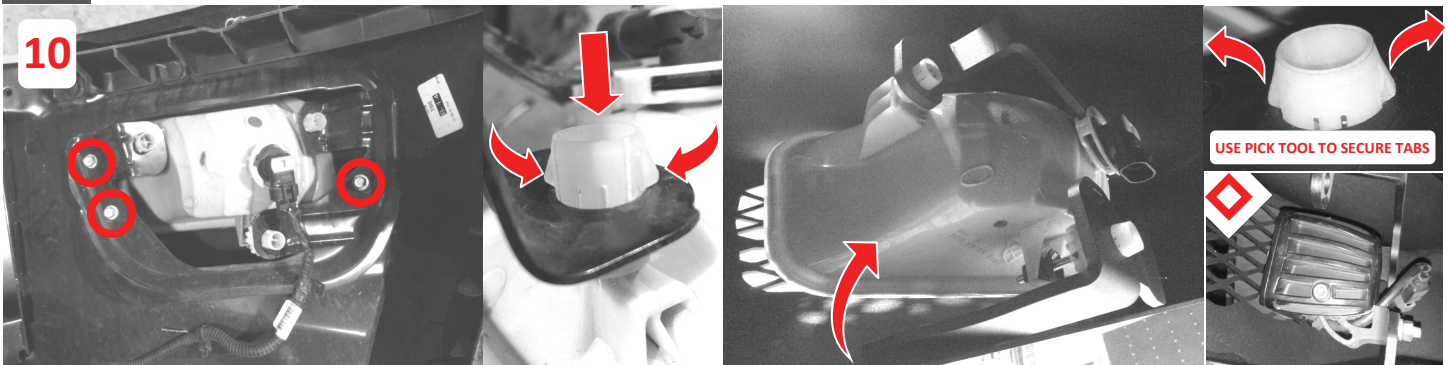

- 11 Using one short bolt tab in the top inside slot both sides, fit up the Vaquero bumper and snug the bolt tab down with a washer, lock washer and nut. This will allow you to make adjustments to fitment, side to side, up/down and in/out.
- 12 Start by tightening one bolt each side of the bracket to secure the bumper's in/out adjustment.
- 13 Then adjust the side to side and up/down and tighten the nut down on the bolt tabs holding the bumper onto the brackets. From here some fine tuning of the fitment can be done. Once satisfied, insert the rest of the hardware, fit up the tow hooks using the long bolt tabs and narrow washers and fully tighten everything down.
- 14 Now install the center section, with bolts through the center section into the main bumper cavity, then washer/lock washer/nut on the inside as shown.

