

RATED #1 IN NEW CONCEPT DESIGN



Vehicle Type: **Hummer H2** Product: **Dakar Rear Bumper**
 '02+ SUV/'04+ SUT Base, Adventure, LUX

GENERAL NOTES:

Parts List (base bumper)
 1 Ea Dakar Full Wrap Rear Bumper

6 Ea 10-24 x 3/4" machine screw, Stainless Steel
 6 Ea 10-24 self locking nut

Parts List (base bumper + Tire Carrier)

1 Ea UHMW Saddle
 2 Ea 1/4-20 x 1/2" Flat Head Screw, Stainless Steel
 2 Ea 1/4-20 self locking nut

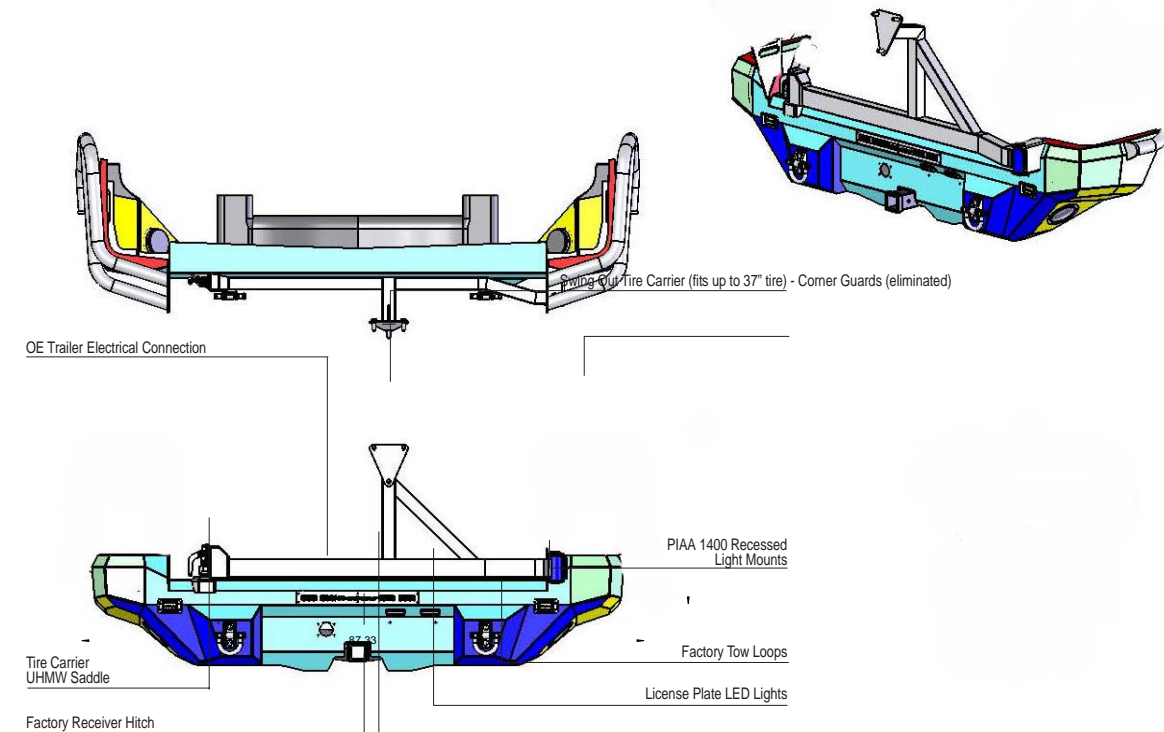
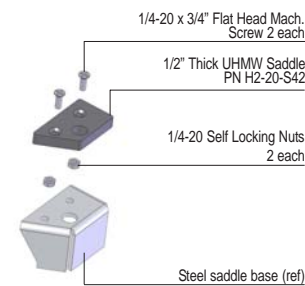
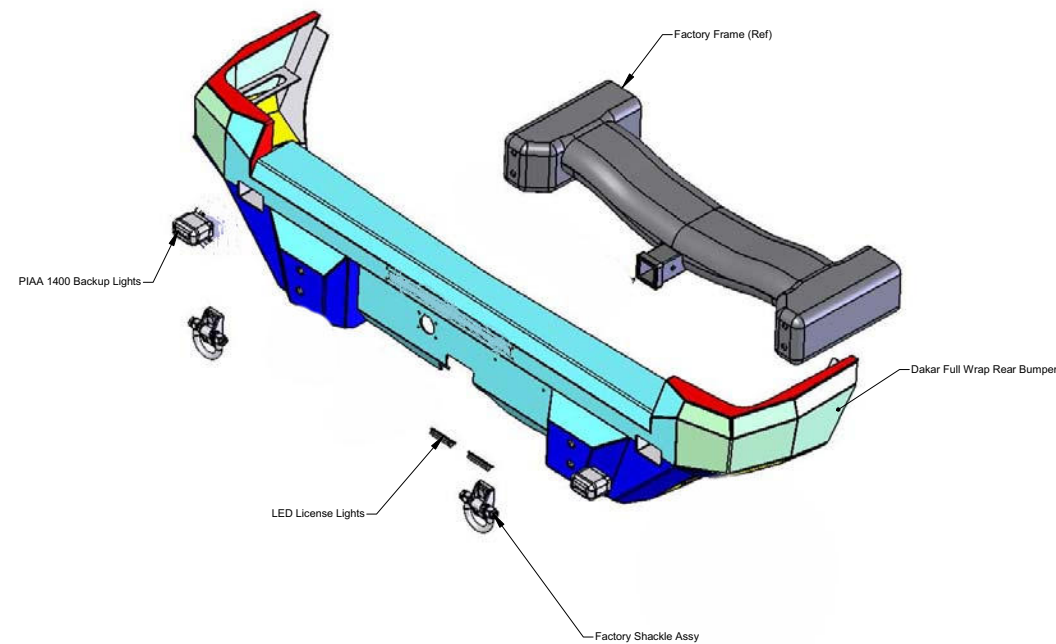

Installation Precedure:

STEP 1) Remove all factory rear bumper components. Factory tow loops will be re-used. Remove factory rear fender flares.
 STEP 2) Install all optional accessories, i.e. PIAA lights, LED lights etc. Install Tire Carrier UHMW saddle as shown
 STEP 3) Position bumper up to vehicle. Carefully move bumper into position around the factory quarter panels and align mounting holes with factory tow loop holes in frame. Place factory tow loops in position on rear face of bumper and thread bolts into frame holes. Position bumper square to vehicle and tighten bolts securely.
 STEP 4) Wire lights as necessary.



KEY FEATURES:

The Dakar is the newest Road Armor advanced design concept to match the rectangular lines of the H2. It features high angle faceted design for exceptional strength to weight.

Fit up to body is exact

Options Include: Swing out tire carrier for up to 37" dia tires.

SPECIFICATIONS:

Product Name: Dakar full wrap rear replacement - Base PN: H2-20
 Application: '02+ H2 SUT/'04+ H2 SUT
 Bumper Material: Primary structure 3/16" H.R. descaled A36 steel. Recovery mounts 3/16" H.R. descaled A36 steel

Steel Plate Construction : CNC laser cut, CNC press brake formed, robotically welded
 Guard Construction: CNC mandrel formed, mig welded
 Finish: All exterior seams machine ground and polished, acid etched powder coat baked on 4 mill thick satin black
 Mounting: Solid four point bolted connection, mounts using factory tow loops.
 OE Safety Compliancy: Air bag compatible, crumple zone compliant
 Skid Plating: Full wrap style
 Accessories: Recessed rectangular light mounts PIAA Ion Crystal Fog PN 1451
 Weight: Dakar base bumper - 110 lbs, Dakar + Tire Carrier 155 Lbs