



BACK UP LIGHT KIT

SR-M / SR-M FLUSH MOUNT

BACK UP LIGHT KIT INSTALLATION INSTRUCTIONS



KIT INCLUDES

- | | |
|---|--|
| 2 - Rigid Industries SR-M/SR-M FM LED Lights | 2 - Stainless Steel (18-8) Mounting Brackets |
| 1 - Custom Back-up Kit Wiring Harness | 2 - Stainless Steel (18-8) Carriage Bolts |
| 2 - Stainless Steel (18-8) ¼" x 1.5" Socket Head Cap Screws | 2 - Stainless Steel (18-8) ¼" Nylon Insert Lock Nuts |
| 2 - Stainless Steel (18-8) Lock Washers | 2 - Stainless Steel (18-8) Standard Nuts |

INSTALLATION INSTRUCTIONS

1. Choose a location for your Rigid Industries back-up lights. Make sure you have clearance for the lights to adjust/rotate without interference and a path for wiring. Mark & drill holes. Secure lights on provided brackets with provided hardware.
2. Route wire harness completely before connecting anything. Once you have run the harness in place and planned your hard attachment locations and zip tie locations, proceed with install. Use the diagram below and the following notes...
 - a. Relay should be mounted under dashboard.
 - b. Switch should be mounted on driver side dashboard. Drill a $\frac{3}{4}$ " diameter hole and feed switch through from the back side.
 - c. If you would like your switch to be illuminated when you kit is in use, connect the black wire to pin 2b on the switch. If you do not wish for your switch to illuminate, simply omit this step.
 - d. The connector between the relay and in-line fuse is there to prevent you from having to get the switch/relay or fuse holder through the fire wall. Drill a small hole or use an existing ingress. Push the red battery line through from vehicle cab. Push the red battery line through from the engine compartment then connect with the in-line connector.
 - e. Red battery connector should be attached to the positive battery terminal. Black battery connector may be connected to negative battery terminal or any suitable ground.
 - f. Reverse light lead must be connected to the factory reverse light line. The lead is long enough to connect at the factory reverse lights – or you can tie in under the dash if you prefer.
 - g. Path for wiring between the relay and the lights is up to you. Take care to avoid heat sources, sharp edges or abrasive surfaces. Secure wiring in place with plenty of zip ties.
 - h. Deutsch connectors should connect to your two Rigid Industries lights.
3. Once the wire harness has been fully installed, you are ready to test out your lights. Middle position on your switch is "off". Down position is "on when in reverse" and Up position is "always on".

Always disconnect battery before servicing any fuses or electrical system.

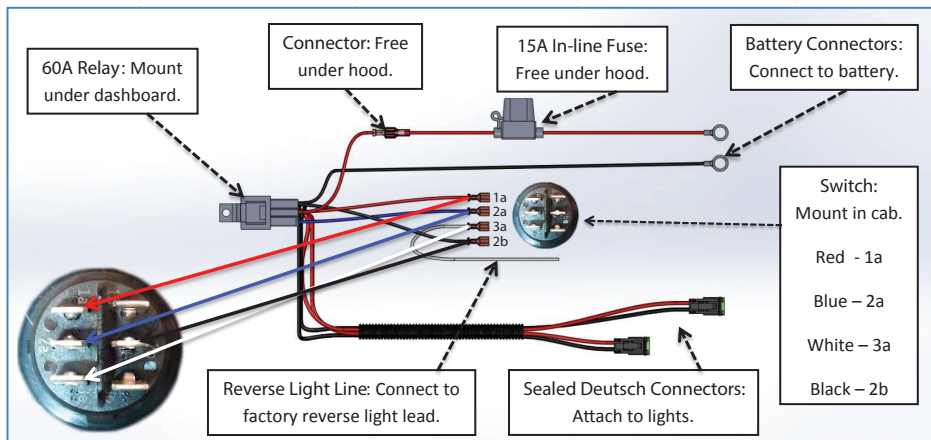

Learn more about tail lights on our website.

MOUNTING TEMPLATE

Rigid Industries highly recommends using a certified professional to install and wire your light.

Only install light onto flat surface

