



## INSTALLATION INSTRUCTIONS

# 2021+ BRONCO SPORT SR & RDS SR MOUNTS



PRODUCT INCLUDES:

Mount #46712

Kit includes mounting brackets, hardware,  
rivnut tool

\* LIGHTS SOLD SEPARATELY

**\*THIS MOUNT FITS THE FOLLOWING LIGHTS:**

**40 Inch SR-Series Single Row Straight Light Bar  
Or RDS SR-Series Single Row Curved Light Bar**

### **IMPORTANT**

**THANK YOU FOR PURCHASING RIGID INDUSTRIES' PRODUCTS FOR YOUR VEHICLE.**

Please read through all of these Instructions and tips before proceeding with the installation.  
We do our best to provide a simple installation process for all applications however  
a professional installation is always recommended.

**Always disconnect any power sources connected to your  
vehicle before servicing fuses or electrical systems.**

## RECOMMENDED TOOLS:

- Portable Drill
- 1/4" and 23/64" Drill Bit
- Center Punch
- 7/8" and 11/16" Box End Wrenches For Supplied Rivnut Tool

**Note:** this is a 2-person installation

## STEP 1

Check which factory rack the Bronco Sport is equipped with. This affects the recommended placement for mounting the brackets.

- Measurement A: Base, Big Bend, and Outer Banks Models
- Measurement B: Badlands Model Only

### VISUAL COMPARISON:

#### Measurement A

Base, Big Bend, and Outer Banks Rack

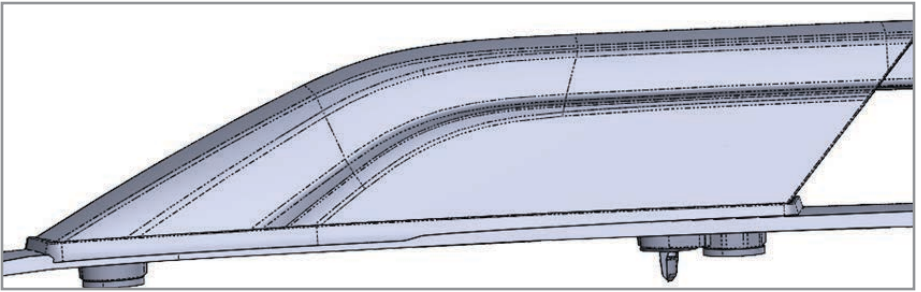

#### Measurement B

Badlands Rack

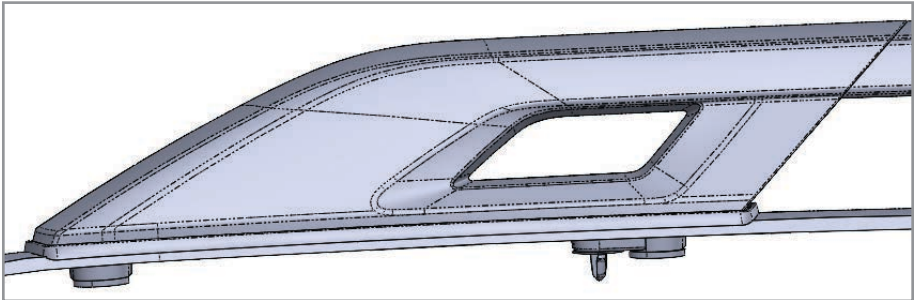

### Measurement A

Base, Big Bend, and Outer Banks Rack

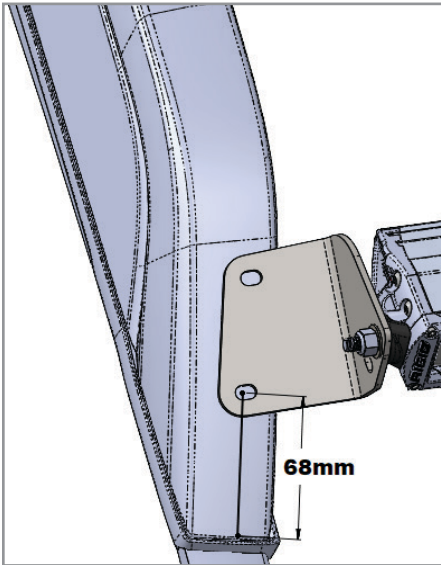

### Measurement B

Badlands Rack

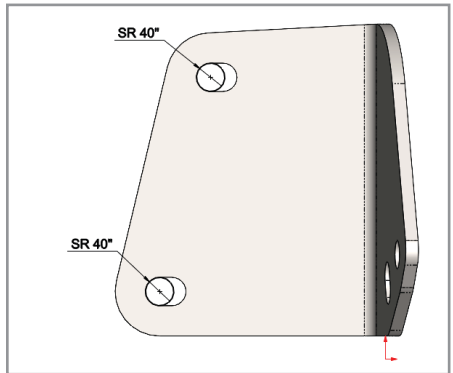
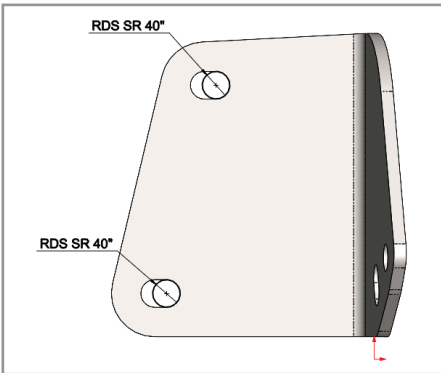
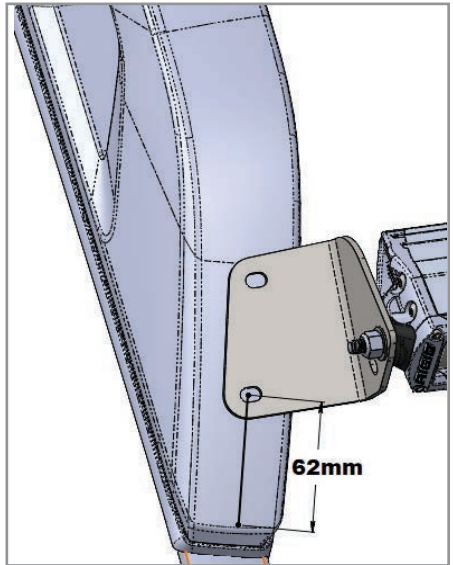

**Note:** These are the recommended locations for rivnuts. This allows for installing either the curved RDS SR-Series or straight SR-Series.

## STEP 2

Using the correct measurement for the vehicle's rack, mockup the light with the brackets to mark hole locations for the rivnuts.

Recommended: tape the location as shown to protect the rack's finish and provide a place to trace the location of the bracket and holes needed, these will be drilled for the installation of the rivet nuts. In the photo, a piece of paper was used to make a template.

FIGURE 2.1



FIGURE 2.2



## STEP 3

When placement of the template is set, center punch the lower hole and proceed to drill the hole with a  $\frac{1}{4}$ " (6mm) bit. Use the supplied 6mm security bolt as a locating dowel pin. Next with another person, hold the light with the brackets attached and check to ensure the lower hole lines up with the template. If it does, use a center punch and drill a  $\frac{1}{4}$ " hole. (See Figure 3.1)

Place a 6mm security bolt on this side to ensure bolt holes line up. (See Figure 3.2)

FIGURE 3.1

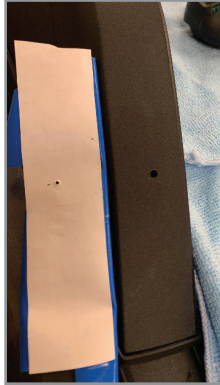

FIGURE 3.2



## STEP 4

Drill the existing holes from the previous steps using a  $\frac{23}{64}$ " bit (See Figure 4.1) or a  $\frac{3}{8}$ " bit (See Figure 4.2). This hole size is for the rivnut.

Check fitment.

FIGURE 4.1



FIGURE 4.2



## STEP 5

To use the supplied rivet tool: thread the rivet nut onto the screw as show. Thread clockwise to install the rivetnut.

Note: Rivet does not have to be 100% bottomed out.

FIGURE 5.1

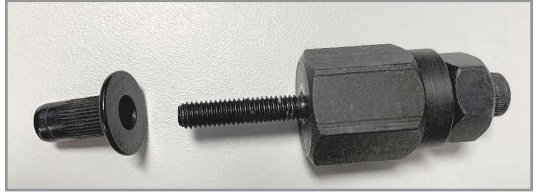

FIGURE 5.2

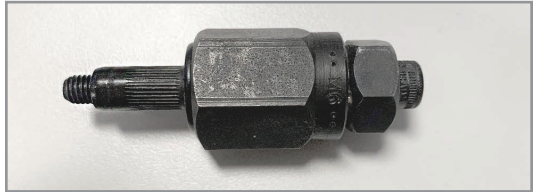
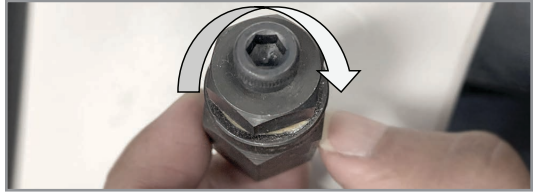

FIGURE 5.3



## STEP 6

Install the rivnuts to the two holes made in the previous steps. Using a ratchet with a 11/16" socket and an open box 7/8" wrench. Once the rivnut has been installed, thread the nut on top of the tool counterclockwise a little, and then unscrew the socket head bolt counterclockwise until the bolt is free.

FIGURE 6.1



FIGURE 6.2



## STEP 7

With the lower holes installed with a rivnut, bolt the brackets with the security bolts. Security bolt comes with a supplied tool for installation. Mark the upper holes. Use a 1/4" bit as a center punch as shown, then use a center punch and drill a hole with the 1/4" bit with the bracket in place as a drill fixture. Repeat on the other side of the rack.

FIGURE 7.1



FIGURE 7.2



FIGURE 7.3



## STEP 8

Proceed to enlarge the hole with a  $23/64$ " bit or a more common  $3/8$ " bit. Install the rivnut, repeat on the other side.

FIGURE 8.1



FIGURE 8.2



## STEP 9

Install the security bolts and washers as shown with the supplied security bolt tool.

FIGURE 9.1

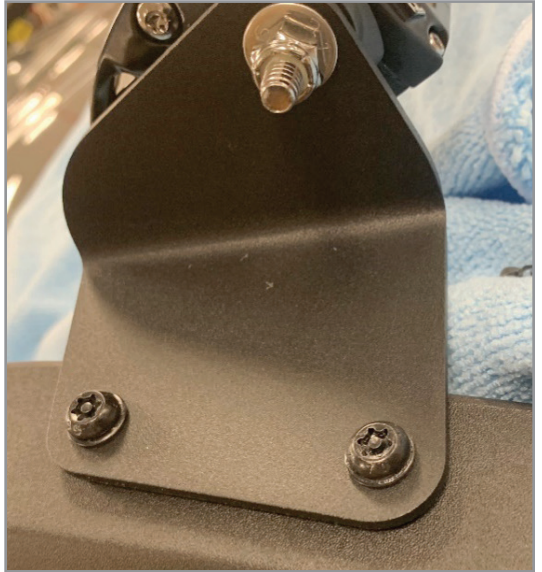

FIGURE 9.2



## STEP 10

Install the supplied end caps for the exposed studs on the end of the light bar. Proceed with wiring of the light bar.

FIGURE 10.1

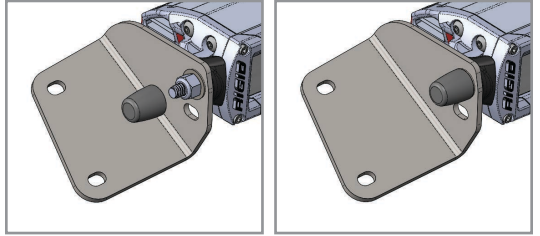

## WIRING INSTRUCTIONS

**Always disconnect the power.**

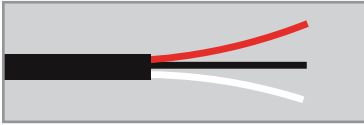

RED WIRE = ON MODE VOLTAGE

BLACK WIRE = GROUND

WHITE WIRE = ADAPT MODE VOLTAGE

1. Always disconnect the negative battery terminal when working with any electrical circuits.
2. If connecting to existing wiring, make sure to use appropriate fusing and wire gauge. Be sure to use heat shrink tubing on all connections to ensure a weather tight seal.
3. Be aware of the current rating of your selected switch, if switch rating is less than the amperage required to power your light then a relay must be added in line to prevent failure of switch.
4. Use wire sheathing to protect the wire if routing through any metal surface or around any sharp edges.
5. Re-connect the negative battery terminal and fully tighten all mounting hardware. Test to verify functionality.