

Right Weigh Load Scales

 **Bluetooth®** Wireless Technology Enabled
Exterior Digital Load Scale

201-EBT-01(B)

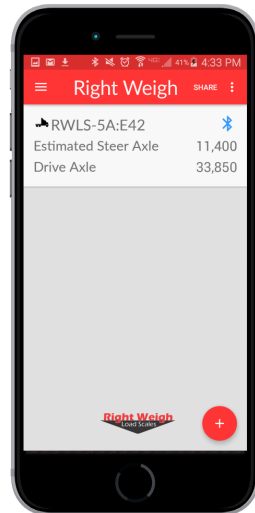

Installation and Operation Manual

Please read carefully before installation

The **Bluetooth**® word mark and logos are registered trademarks owned by Bluetooth SIG, Inc. and any use of such marks by Right Weigh, Inc. is under license. Other trademarks and trade names are those of their respective owners.



Bluetooth® Wireless Technology Enabled

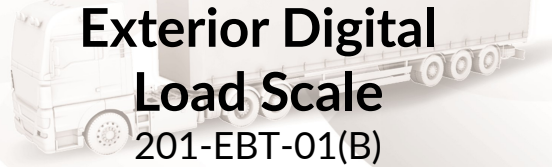

Exterior Digital Load Scale

201-EBT-01(B)

Table of Contents

Specifications & Overview	4
Scale Installation and Electrical Connections	6
Calibration	8
Operating and Weighing Instructions	10
Scale Operating Modes	11
Estimated Steer Mode	12
Multiple Calibration Mode	14
Security PIN Code	15
Overweight Warning	16
Right Weigh Bluetooth™ App Overview	17
Unique Scale Identifier	18
Syncing your Device	19
Set the Load Scale Name	23
Settings & Sharing	24
Troubleshooting	25
Appendix A - Additional Parts	27
Appendix B - Wiring Insulation	28
Warranty Statement	29
Return Policy & Repairs	30

The Right Weigh 201-EBT-01(B) digital load scale has **one** internal air pressure sensor. This scale will monitor one air suspension single, tandem, or tridem drive axle group or trailer axle group with one Height Control Valve (HCV).

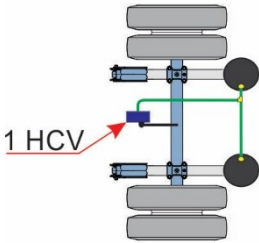

Single Axle Group

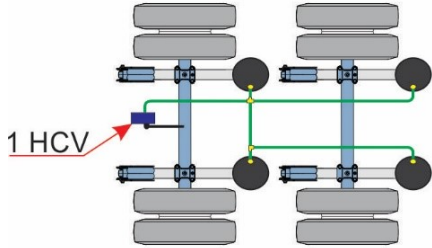

Tandem Axle Group

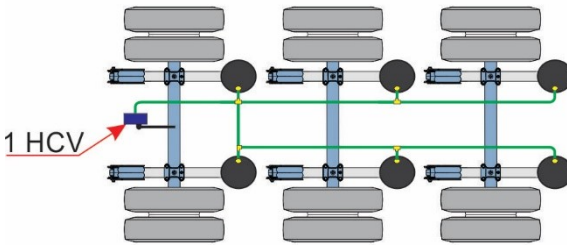

Tri Axle Group



The 201-EBT-01(B) digital load scale cannot be used on an axle group that has two HCVs. To monitor an axle group that has two HCVs you will need the 201-EBT-02(B) digital load scale.

Technical Specifications

Operating Temperature: -22° F to +185° F (-30° C to +85° C)

Storage Temperature: -40° F to +185° F (-40° C to +85° C)

Power Supply: 9 VDC to 32 VDC (Switched)

Units: Pounds (LBS) or Kilograms (KG)

Housing: High impact polycarbonate blend

Display: 0.8" LCD sunlight readable

Specifications & Overview

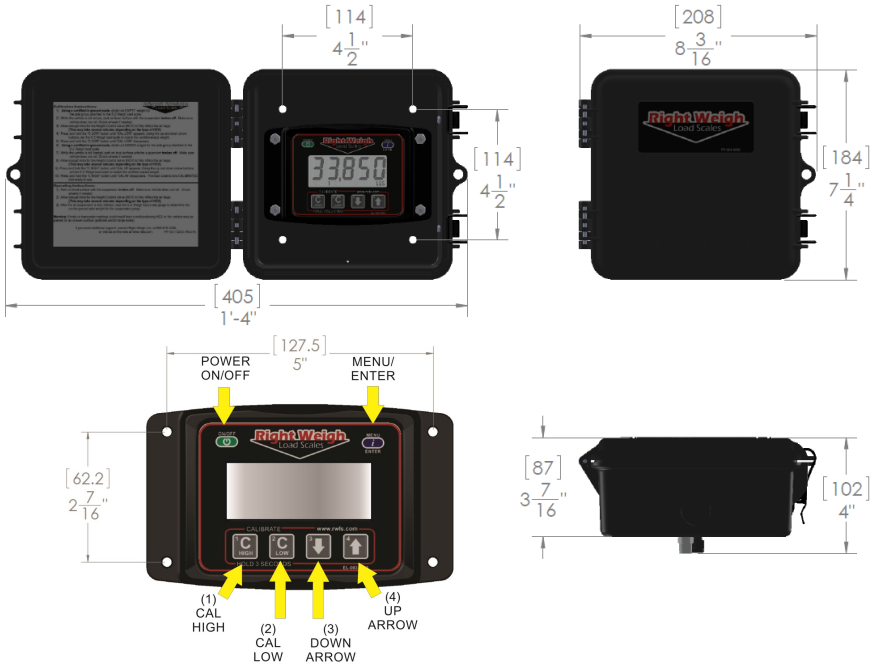

Drop Axle:

This load scale can be used to monitor an axle group with an air ride lift axle if the lift axle air bags are controlled by the same height control valve as the other axles in the group. The scale will need to be setup using multiple calibration mode. Refer to the [Multiple Calibration Mode](#) section for more information.



Independent regulated lift axles cannot be considered part of an axle group.

Estimated Steer Axle:

The weight of the steers can be estimated if this scale is used to monitor the drive axle group. Refer to the [Estimated Steer Mode](#) section for more information.

The 201-EBT-01 scale is designed to be mounted on the outside of a truck or trailer, however it must still be mounted in a protective enclosure. A protective box and mounting bracket are included with the 201-EBT-01B. Choose a location on the vehicle to mount the scale that is easily accessible and safe from potential damage (Forklift posts, tire caps, etc.).

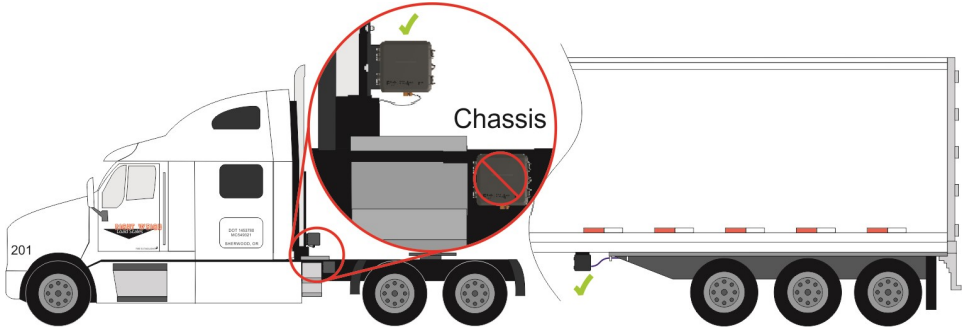

DO NOT mount the scale directly to the chassis or any other main beam unless it is approved by the vehicle manufacturer. Doing so may void the warranty with the vehicle manufacturer.

Step 1: Mount the supplied bracket in the chosen location and install the protective box to the bracket using the supplied hardware.



Step 2: Dump the air from the suspension system. Locate and remove the suspension air line fitting from the top of one of the air bags connected to the height control valve.



Scale Installation and Electrical Connections

3: Insert a street tee fitting into the top of the air bag. The street tee fitting should match the thread size and type of the vehicle suspension. Reinstall the suspension air line and fitting into the street tee. For a list of recommended hardware, please see Appendix A.

Insert suspension air line and fitting into the tee fitting



4: Install a new 1/4" air line and fitting to be used with the Right Weigh load scale into the street tee.

Insert new air line and fitting into the tee fitting



5: Run the new 1/4" air line from the street tee fitting to the mounting location of the Right Weigh load scale. Insert the new air line into the push-to-connect fitting on the back of the load scale. Use zip ties to safely secure the air line to the truck or trailer along the way.

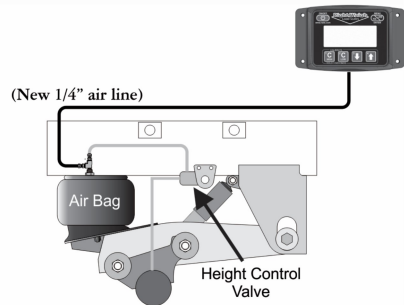

6: Air up the suspension system and check all air fitting connections for leaks.

7: Attach the RED wire on the back of the gauge to a **SWITCHED** positive (+) power source (**DO NOT connect directly to the battery**) and the BLACK wire to chassis ground (-). The required supply voltage must be between 9 and 32 volts DC.

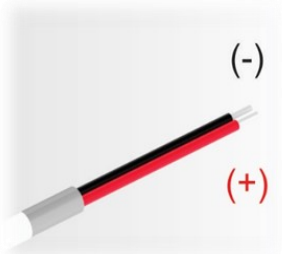

Electrical connections must be insulated from weather to protect scale and wiring from damage. See Appendix B

The 201-EBT-01(B) load scale must be calibrated both empty and loaded to work properly. The scale associates the air pressure in the suspension system to the weight you enter at the time of calibration. You will need to calibrate once while the vehicle is empty, and again while the vehicle is loaded for each axle group being monitored.

1. Empty Calibration Point

- 1: While the vehicle is empty, obtain a weight from a certified in-ground scale for the specific axle group or groups attached to the Right Weigh load scale.
- 2: Park on a level surface. Shift the transmission to neutral and set the parking brakes. Chock the wheels to prevent unexpected vehicle movement, then release the parking and service brakes.
- 3: Make sure the Height Control Valve (HCV) has fully inflated the air bags. If needed, briefly dump the air from the suspension and allow the HCV to refill the system. (This may take several minutes depending on the type of HCV.)



4: Press the ON/OFF button to turn on the Right Weigh load scale. Press and hold the C LOW button until the "C/L" symbol appears.



5: Adjust the value using the UP and DOWN arrows so that it matches your scale ticket for the axle group.



6: To save, press and hold the C LOW button until the "C/L" symbol disappears.



Weigh the entire axle group being monitored. Do not use values such as gross weight, tare weight, or just a single axle weight from a tandem etc. When entering the loaded weight value, be sure that your vehicle is as close to the maximum legal weight limit as possible.



2. Loaded Calibration Point

1: While the vehicle is fully loaded, obtain a weight from a certified in-ground scale for the specific axle group or groups attached to the Right Weigh load scale.

2: Park on a level surface. Shift the transmission to neutral and set the parking brakes. Chock the wheels to prevent unexpected vehicle movement, then release the parking and service brakes.

3: Make sure the Height Control Valve (HCV) has fully inflated the air bags. If needed, briefly dump the air from the suspension and allow the HCV to refill the system. (This may take several minutes depending on the type of HCV.)



4: Press the ON/OFF button to turn on the Right Weigh load scale. Press and hold the C HIGH button until the “C/H” symbol appears.



5: Adjust the value using the UP and DOWN arrows so that it matches your scale ticket for the axle group.



6: To save, press and hold the C HIGH button until the “C/H” symbol disappears.

Once both empty and loaded calibration has been performed, the scale is ready to use! If you have any trouble entering calibration data, refer to the troubleshooting section of this manual.

In order for the gauge to provide the most accurate weight values, you must take care to position the vehicle correctly. For best results, follow these steps:

- 1: Park on a level surface. Shift the transmission to neutral and set the parking brakes.
- 2: Chock the wheels to prevent unexpected vehicle movement, then release the parking and service brakes.
- 3: Make sure the Height Control Valve (HCV) has fully inflated the air bags. If needed, briefly dump the air from the suspension and allow the HCV to refill the system. (This may take several minutes depending on the type of HCV.)



4: Press the ON/OFF button to turn on the Right Weigh load scale.

5: Adjust the suspension or the load itself until the Right Weigh load scale displays a weight value below your legal limit.



6: Press the ON/OFF button to turn off the Right Weigh load scale.

- The display will turn itself off after 60 minutes.



- To change the units from pounds to kilograms, hold the UP arrow button, then press the MENU button.

Scale Operating Modes

The next few pages cover the operation modes that are built into the 201-EBT-01(B). The load scale can only be setup in one operating mode at a time. If the mode is changed, the calibration data will be reset to factory defaults, requiring re-calibration.

Average Mode (AVG): This is the default mode of the scale.

Estimated Steer Mode Average (S-AVG): For monitoring a drive axle group weight and also calculating an estimated steer axle weight based on the weight ratio between the drive axle group and the steer axle.

Multiple Calibration Mode (4CAL): Four sets of calibration data can be stored for use when the axle group is weighed under different conditions, such as when an integrated air ride lift axle is used on the same HCV.

Changing Scale Modes:

1: With the scale **OFF**, hold both the UP and DOWN arrow buttons, and press the ON/OFF button. Release all 3 buttons. The scale will display the current mode.



2: Press the UP arrow button to cycle through the configuration modes. To confirm your selection, turn the scale off by pressing the ON/OFF button.



In Estimated Steer mode, a 201-EBT-01(B) which is installed on a single height control valve tractor to monitor the drive axle group, can also estimate the steer axle weight. In this mode, there is a small number in the lower left of the display, either 1, 2, or 1 & 2 simultaneously. This is to let you know which axle group is being displayed. Axle group 1 displays the estimated steer axle weight, axle group 2 is the drive axle group weight, and 1 & 2 are the two weights combined.



Use the MENU button to switch the display between the axle groups.

Estimated Steer Mode - Average - Calibration Steps

The scale must be calibrated both empty and loaded. When calibrating in this mode, you must obtain separate weights for both the drive axle group and steer axle from a certified in-ground scale. During calibration and weighing, the truck and trailer must be on flat level ground with the brakes off and wheels chocked. Refer to pages 8 and 9 for more information.

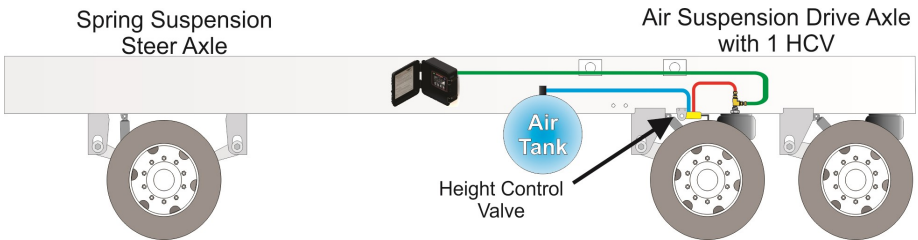

1. Empty Calibration Point

1: Obtain separate empty weight values for the steer axle and drive axle group from an in-ground scale.



2: Press the MENU button until the scale displays axle group 1. Press and hold the C LOW button until the “C/L” symbol appears.



3: Adjust the value using the UP and DOWN arrows so that it matches your scale ticket for the steer axle. To save, press and hold the C LOW button until the “C/L” symbol disappears.



4: Press the MENU button to switch the display to axle group 2 and repeat the process for the drive axle group.

2. Loaded

1: After the truck has been fully loaded, obtain separate loaded weight values for the steer axle and the drive axle group from an in-ground scale.



2: Press the MENU button until the scale displays axle group 1. Press and hold the C HIGH button until the “C/H” symbol appears.



3: Adjust the value using the UP and DOWN arrows so that it matches your scale ticket for the steer axle. To save, press and hold the C HIGH button until the “C/H” symbol disappears.



The 201-EBT-01(B) digital load scale can be used in a mode which stores 4 sets of calibration data. This can be useful for an axle group which has an integrated air ride lift axle using the same HCV, or a suspension which has many operating conditions.

Calibration



The calibration process is the same as Average mode, however, you now have the ability to change between 4 calibration sets using the MENU button. When calibrating, make sure to calibrate both empty and loaded for each calibration set that you plan on using.

Operation



Use the MENU button to switch between the saved calibration sets. A number will appear in the lower right letting you know which calibration set is active.

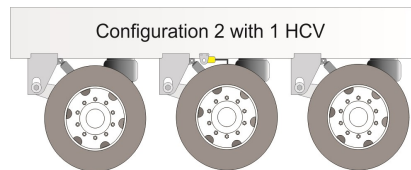
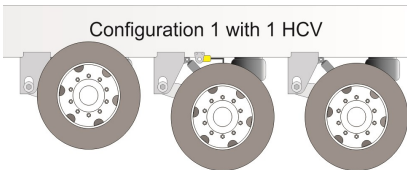

Security PIN Code

A security PIN code can be added to the 201-EBG-01(B) to prevent tampering with the scale. It will need to be entered to change the calibration values, or to change the PIN code. Keep a copy of the PIN code for future use. Once a PIN has been set, it can be changed, but it cannot be removed.

Setting a PIN Code

1: With the gauge **OFF**, hold both the C LOW and C HIGH buttons, then press the ON/OFF button. Release all three buttons.

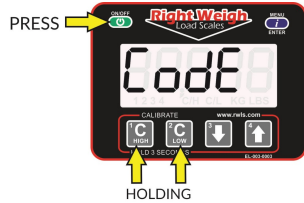

2: Press the MENU button. The display will show "00000". If the display shows "- - - - -" it means there is already a code set. Enter in a 5 digit PIN code using buttons 1, 2, 3 and 4. Press the MENU button again to save the PIN.

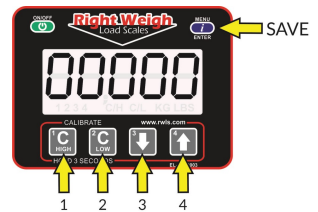

Changing your PIN Code

1: With the gauge **OFF**, hold both the C LOW and C HIGH buttons, then press the ON/OFF button. Release all three buttons.

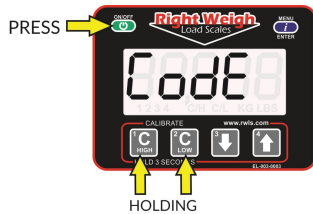

2: Press the MENU button. The display will show "- - - - -". Enter the previous PIN code. If the correct code was entered, The display will show "Good".

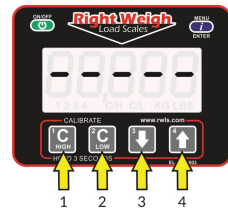

3: Press the MENU button, and enter the new 5 digit PIN code using buttons 1, 2, 3, and 4. Press the MENU button again to save the new PIN.



As an added visual warning, the display can be set to flash when above a set weight. For example, you may choose to have the display flash any time the weight on the axle group goes above 33,500 pounds.

Setting an Overweight Warning

1: With the scale turned on, press and hold the C HIGH and C LOW buttons. After 3 seconds, the “C/H” symbol will appear.



2: The display will show the warning value. “0” is the default setting and the display will not flash the weight at any time if it is set to “0”.



3: Use the UP and DOWN arrow buttons to set the desired warning weight. Press and hold the C LOW and C HIGH buttons to save.



Setting the warning value to “0” will disable the overweight warning feature.

Right Weigh Load Scales App Overview

When connected with **Bluetooth**[®] wireless technology enabled Right Weigh load scales, axle group weight readings are displayed on the *Right Weigh Load Scale App*.

The basic steps to connect your Right Weigh load scale to your smart device are:

- Discover the unique name of your load scale(s)
- Setup your load scales to the desired configuration
- Sync your load scale(s) with your smart device

1. Menu, Settings and Support: Use this button to view stored weight data, change the unit of measure (LBS or KG), set warning weight and overload weights, change or add weight data settings and to toggle the option to show the support page on app startup.

2. Scale Name (Truck): The name of the connected truck-mounted scale appears here. Tap the name to set a new name for the scale. The name you set will be saved to the scale itself and the scale will be identified by that name in the future when visible to a device.

3. Scale Name (Trailer): Names of connected trailer-mounted scales appear here. Tap the name to set a new name for the scale. The name you set will be saved to the scale itself and the scale will be identified by that name in the future when visible to a device.

4. Axle Group Name: This name represents the axle group which the scale is monitoring and reflects the operating mode of the scale.

5. Share: This button will open the share data view to send weight data via email.

6. Total Weight: Shows vehicle's total weight

7. Signal Status: A blue icon represents that the device is connected to the scale and is receiving data. A grayed-out icon means the scale has been disconnected. Pressing the refresh button will attempt to reconnect the device to the scale.

8. Add a Scale: Press the "+ Truck" button to add a truck mounted scale to the app. Press the "+ Trailer" button to add a trailer mounted scale to the app.

App Home Screen



Unique Scale Identifier

Unique Scale Identifier:

If this is the first time you have used the Right Weigh load scale, you will need to enter a special mode to view the scale's unique identifier. This will help identify the scale when syncing more than one scale with your smart device.

1: With the scale display **OFF**, hold down the MENU button, then press the ON/OFF button. Release both buttons.

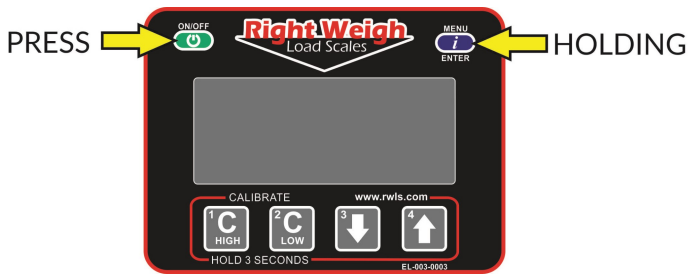

2: Press the MENU button twice to display the unique identifier.





Step 1: Press (+) from the home screen of the app.

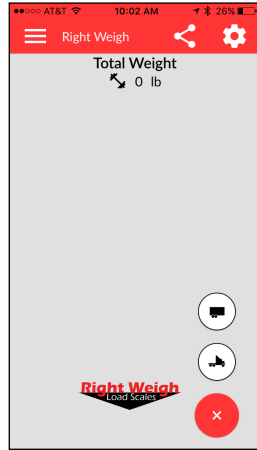

Step 2: If the scale is mounted to a truck, press the truck icon. If mounted to a trailer press trailer icon.

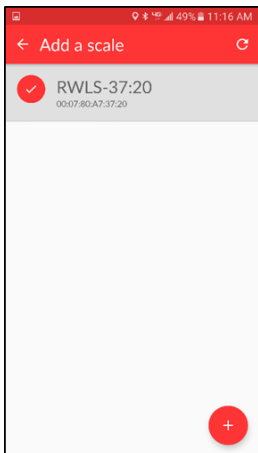

Step 3: Select the load scale matching the unique identifier of the scale you wish to sync with. Tap (+)

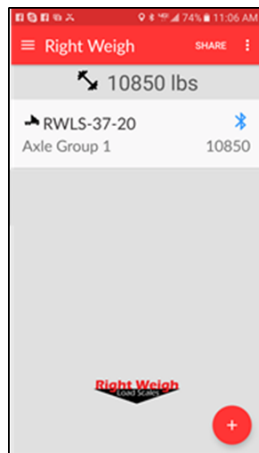

Step 4: The axle group weight will now appear on the home page of the app.

Syncing your Device



Step 1: Press (+) from the home screen.

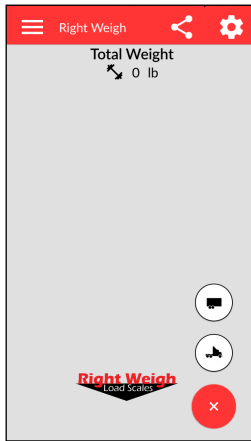

Step 2: If the scale is mounted to a truck, press the truck icon. If mounted to a trailer press trailer icon.



Step 3: Select the load scale matching the unique identifier of the scale you wish to sync with. Tap (+) icon.

If your gauge is setup in the default **Average Mode (AVG)**, you will see the axle group weight displayed.

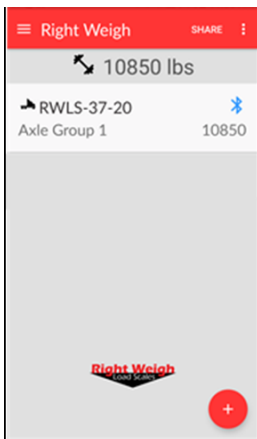

If your gauge is setup in the **Estimated Steer Mode Average (S-AVG)**, you will see the estimated steer axle and drive axle weight.

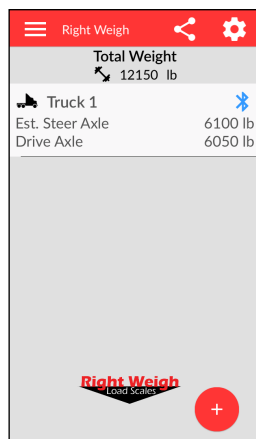

If your gauge is setup in **Multiple Configuration Mode (4CAL)**

, you will see all of the configurations available. The inactive configs will be

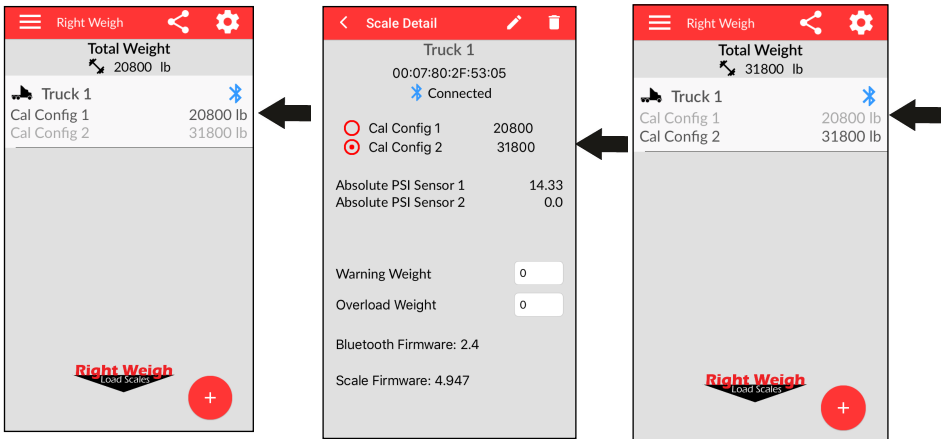

To switch the active configuration, select the load scale on the home screen then select the desired configuration. Press the back arrow.

Set the Load Scale Name

To re-name a scale, tap on the name of the scale from the home screen of the app. Enter the new name, and press return in the keypad. The name you enter will be saved to the scale itself, and will replace the default name. When syncing with your scale in the future, this name will display in the app.



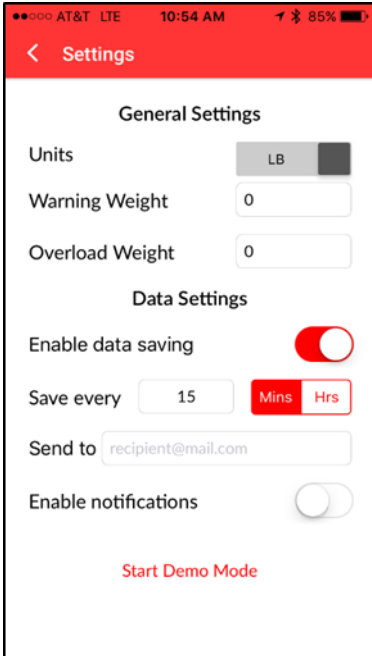

Share View

To share your current loaded weigh with others via e-mail or text, tap the share button in the top right corner of the home screen. The share data interface will appear. Choose e-mail or text and enter the contact information of the person you wish to send your data to and press send.

Settings View

In the setting view screen, you have the option to switch between LBS and KG. Furthermore, you can toggle the system support page on startup of application.

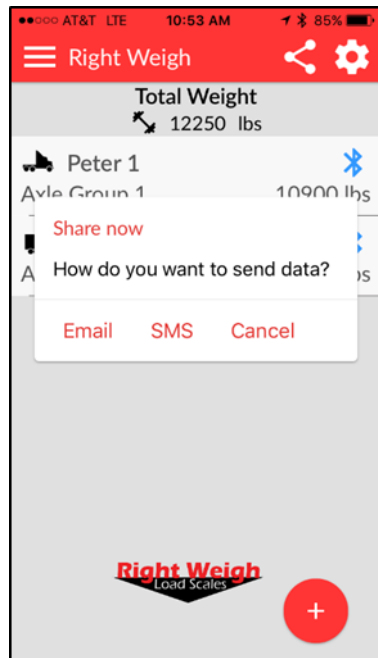

Troubleshooting

Erratic or inaccurate readings

The vehicle is not parked on a level surface	Parking on sloped or banked surfaces will cause the vehicle weight distribution to shift between the axle groups.
The vehicle's brakes are on	When the vehicle brakes are set, they could apply additional pressure or torque on the suspension air bags. This will cause the suspension to have a different air pressure than what is actually needed to hold up the given weight.
The vehicle is parked on an uneven or rough surface	If one or more of the vehicle's wheels are in a pothole, that could result in additional pressure or torque on the suspension air bags. This will cause the suspension to have a different air pressure than what is actually needed to hold up the given weight.
The Height Control Valve (HCV) is malfunctioning or broken	If the HCV is not functioning correctly, the air pressure applied to the suspension system could be inconsistent and/or erratic. To test for an HCV problem, acquire a weight reading from the Right Weigh load scale and write it down (refer to scale operating instructions for proper procedure). Drive the vehicle around the block and return to the same location. Acquire a second reading from the Right Weigh load scale. If the two readings are significantly different, then the HCV might be malfunctioning.
There is a significant air leak in the suspension system	This could cause the HCV to refill the suspension at regular intervals to maintain the vehicles ride height. If there is a significant leak, the scale display will slowly decrease in value and then quickly increase in value when the HCV refills the suspension system.
App won't connect to Bluetooth scale	Power cycle scale by removing the power source and reconnecting power source.

Scale does not power on:

Scale is not connected to a switched power source of between 9 and 32 volts	If there is a bad connection in the circuit which causes voltage to drop below 9 volts, the scale will not power on. Test the power source with a voltmeter.
Scale Connected Directly to Battery	The scale is active anytime it is connected to power, even if the display is off. To reset it, disconnect and reconnect the power source, wait 10 seconds, then try again to turn the display on.
Polarity is incorrect	The red wire must be connected to positive, and the black to negative.

Scale Display is Blinking

Current weight is above the alarm limit programed by the user	With scale on, press and hold the 1 & 2 buttons simultaneously. The display will show the alarm limit weight. To remove the alarm weight, set this number to 0 using the down arrow, and then hold 1 & 2 again until the display is cleared.
---	--

Cannot Change Calibration Data

The scale has an active user-defined security PIN.	If the scale is protected with a passcode, the PIN number must be entered before calibration data can be changed. The scale will display "CodE" and the previously set 5 digit PIN number must be entered to
--	--

Scale will not Calibrate Low

Air Pressure in system is not changing	<p>To enter low cal mode, the 201-EBT-01B load scale must see a measurable change in air pressure from when you calibrated high.</p> <ul style="list-style-type: none"> • Make sure you calibrate high while your trailer is near the legal limit, and cal low when the trailer is empty. • Be sure the air line is connected directly to an air bag and not connected to the main air supply or air brake system.
--	--

Appendix A - Additional Parts

The following is a list of additional parts needed for air line installation. This list is just a suggestion and may not be all of the parts needed for your specific vehicle. Check with your Right Weigh dealer for optional installation kits.

- Approximately 20 to 30 feet (6 to 9 meters) or more of 1/4" rigid air line.
- Street tee fitting. The thread size should match the air bag fitting. (1/4" NPT or 3/8" NPT)
- Male straight air line fitting for 1/4" air line, with a thread size to match the street tee fitting.
- 20 or more zip ties.

1/4 Inch Air Line



Street Tee Fitting

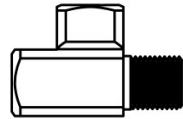

Male Straight Fitting

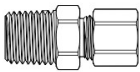

20 or More Zip-Ties



It is very important that all wiring connections be made watertight. Connections which are not watertight will allow moisture to travel through the individual strands of the wires and make it's way into the scale, causing permanent damage to the electronics.

Heat shrinkable splices are included with the 201-SK installation kit.

Crimp each end of the wire into the connector with a wire crimp tool (tool not provided).

With a heat gun or heat torch, heat the connector until it shrinks completely around each wire end. Make sure you do not burn the wire jacket.



After all connections have been made, completely wrap the cable connections with electrical tape, heat shrink tubing, or other environmental protections.

