



81234005 2009-2015 Dodge 1/2 Ton

Congratulations - your new LevelTow [Helper Springs](#) are quality products capable of improving the handling and comfort of your vehicle. As with all products, proper installation is the key to obtaining all of the benefits your kit is capable of delivering. Please take a few minutes to read through the instructions to identify the components and learn where and how they are used. It is a good idea to start by comparing the parts in your kit with the parts list below.

Components

AIR SPRINGS	2020	2
UPPER AIR SPRING SPACER	5690	2
UPPER AIR SPRING MOUNTING PLATE	5505	2
90 DEGREE AIR FITTING	2201	2

Hardware

UPPER MOUNTING STUDS 3/8"-16 X 2 1/2"	99375001	4
UPPER MOUNT FLATWASHER 3/8" SAE	99373003	4
UPPER MOUNT LOCK WASHER 3/8"	99373005	4
UPPER MOUNT HEX NUT 3/8"-16	99372004	4
LOWER AIR SPRING ATTACHING BOLT 1/4"-20 X 3/4" SHCS	99251005	2



Installation Instructions



Disassembly and Air Spring Assembly

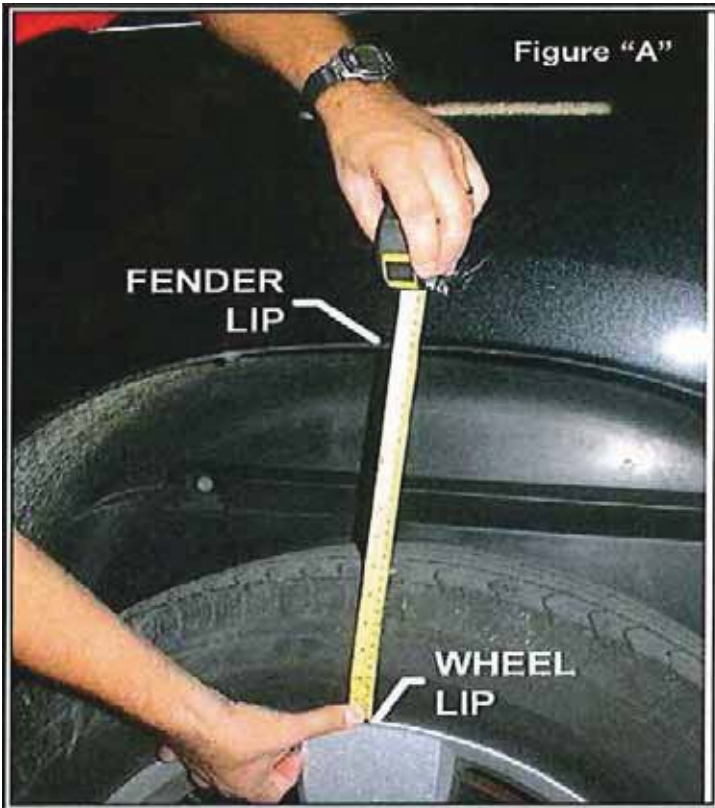

STEP 1: PREPARE THE VEHICLE

Place the truck on a flat surface. Measure and record the height in compressor system instructions. The most accurate way to measure this height is to measure from the lip of the rim to the fender directly above the wheel center (Figure A). Or you can measure from the fender to the ground at the wheel center.

Raise the truck, or the rear of the truck to allow the suspension to relax supporting the truck from the frame. Remove the wheels and the fender liners on both sides.

STEP 2: REMOVE STOCK SHOCKS AND SPRINGS

Support the axle with a Jack underneath it. Remove the lower shock bolt from both sides of the truck (Figure B). Slowly lower the axle to take tension off the coil springs until they are loose. Remove the springs and upper mount. Remove the upper bolt from the shocks to remove them from the truck.

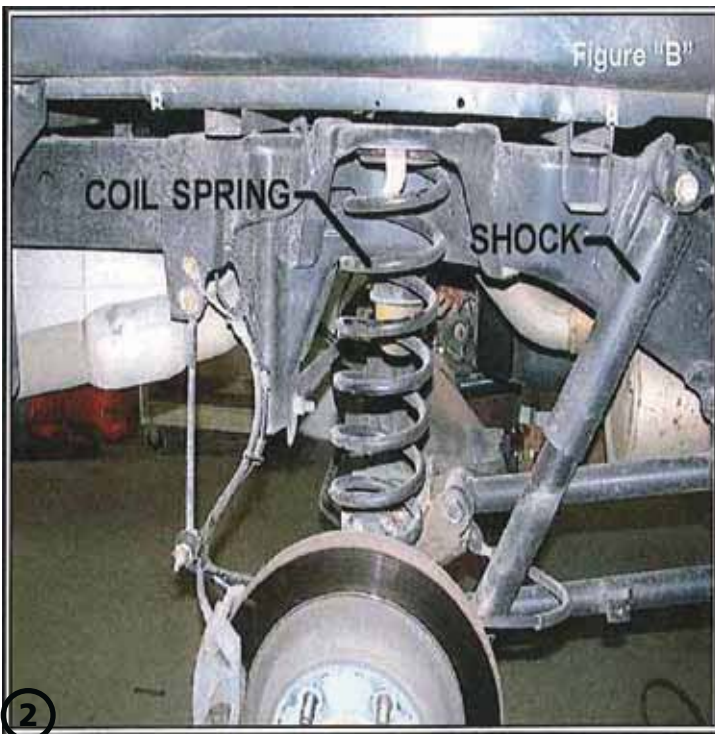

STEP 3: INSTALL THE NEW SHOCKS

Install the new shocks supplied with the kit using the original hardware. The axle will have to be jacked up to attach the lower bolt.

STEP 4: PREASSEMBLE THE AIR SPRINGS

Put thread sealant onto the threads of the 90 degree fitting and install them into the air springs. Install the 4 threaded rods into the top of the air spring. Slide the upper mount over the studs so the flat surface is facing the air spring.

STEP 5: INSTALL THE AIR SPRINGS

The bottom of the air spring assembly has a threaded hole that must face the rear of the truck and the air fitting should face the front of the truck. Place the air spring assembly on the lower axle mount. Using the 1/4"-20 x 3/4" socket head cap screws provided, secure the bottom of the air spring assembly to the lower mount.



Installation Instructions



Air Spring Installation

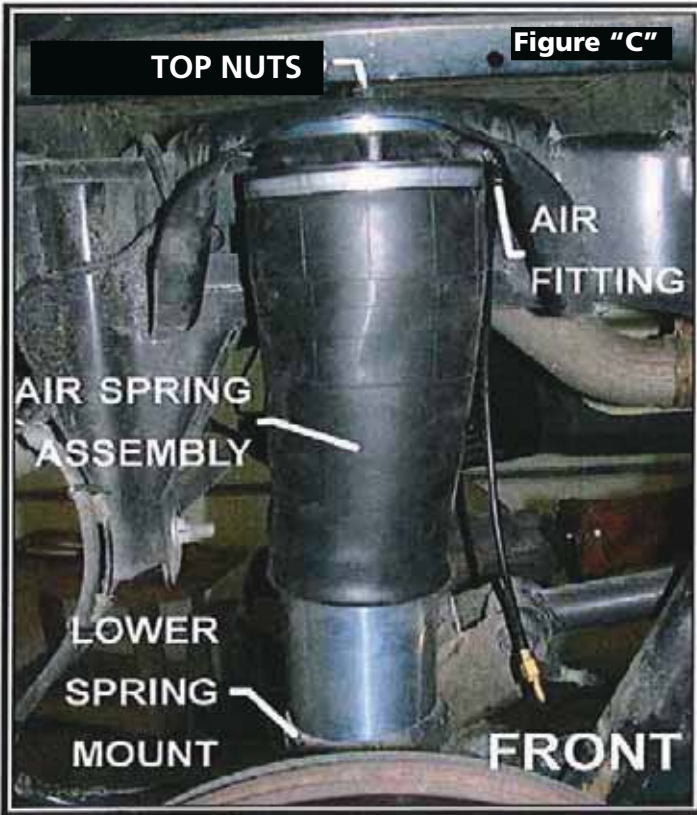

STEP 5: CONTINUED

Place the top plate on the top side of the upper mount. Unroll the air spring, by pushing the top of the air spring up, until the air spring assembly reaches the upper mount of the truck. Place the top plate above the truck's upper spring seat by aligning the top plate to accept the threaded studs from the air spring assembly. Install a flatwasher, followed by a lock washer on each stud. Install a 3/8"-26 nut on each stud and hand tighten (Figure C). **DO NOT ALLOW THE AIR SPRING SLEEVE TO TWIST.** Once the air fitting is correctly align towards the front of the truck and you have ensured the air spring sleeve is not twisted, tighten the 3/8"-16 nuts (Figure H).

STEP 6: COMPRESSOR SYSTEM INSTALLATION

Refer to compressor system instructions for installation.

STEP 7: PLACING THE TRUCK BACK ON THE GROUND

With the compressor system in manual mode (round button not pushed in) use the manual switch to inflate the air springs slightly. Ensure the sleeves are rolling over the pistons and are not bound or twisted. **See Figure "D", "E", & "F".**

Reinstall the fender liners and wheels. Slowly lower the truck to the ground, checking frequently to make sure the sleeves continue to roll over the piston.

Once the truck is on the ground, increase the pressure in the air springs so that the measurement from the fender lip is the same as you recorded earlier. This is the height that you will want the arm on the sensor to be level.

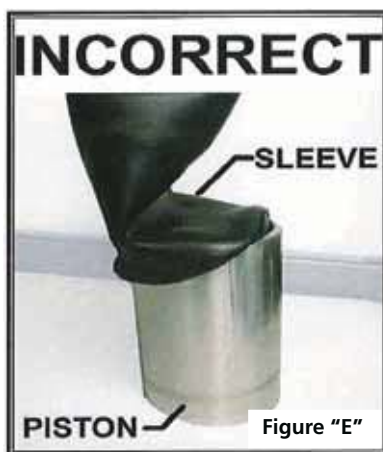
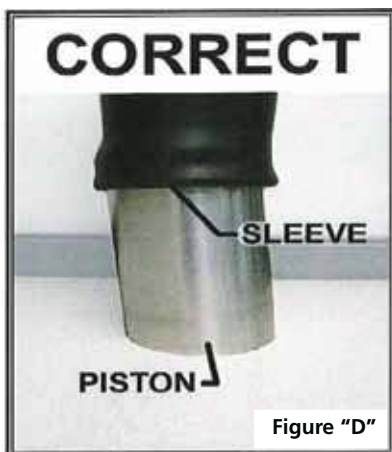

LevelTOW

ADVANCED TOWING SOLUTIONS
by ridetech

LevelTow Compressor System

Congratulations - your new LevelTow Compressor System is a quality product, that when used in conjunction with the LevelTow helper Air Springs, is capable of improving the handling and comfort of your vehicle. As with all products, proper installation is the key to obtaining all of the benefits your kit is capable of delivering. Please take a few minutes to read through the instructions to identify the components and learn where and how they are used. It is a good idea to start by comparing the parts in your kit with the parts list below.

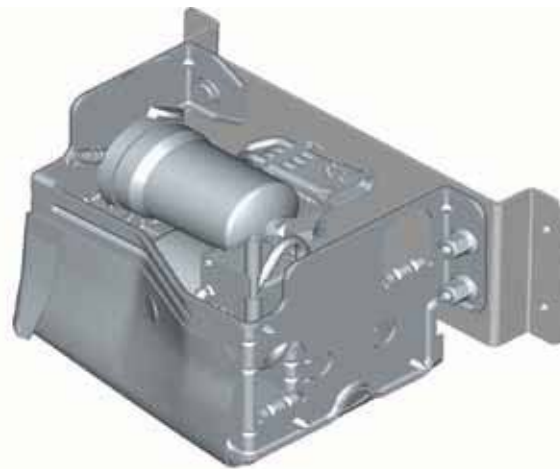
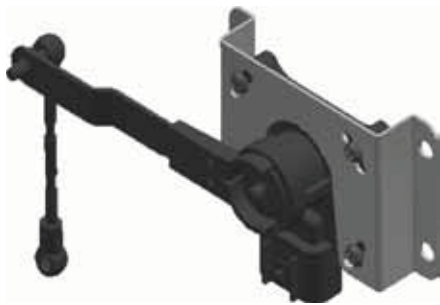

Components:

	Part #	QTY
Compressor Unit	31920012	1
Smart Sensor Height Sensor	70010596	1
Compressor Mounting Bracket	90002440	1
Smart Sensor Mounting Bracket	70010596	1
Sensor Linkage	31980001	1
Linkage Axle Bracket	70011429	1
Control Panel Bracket	70011439	1
Airline Adapter (mounted to compressor)	70011436	1
Airline Cartridge Fitting (mounted in compressor)	31954500	1
Main Activation Switch	35970000	1
Manual Control Switch	70011413	1
Main Wire Harness	31900051	1
Axle Bracket Clamp	99000005	1
1/4" TEE Fitting	31954400	1
1/4" Fitting for airsprings Straight / 90 Degree	31954000 / 31954201	2
Heat Shrink tubing for Sensor linkage	90002030	2
20 amp fuse	90001922	1
Fuse Holder	90001924	1
10-12 Butt Connector for Fuse Holder	90001913	1
Ring Terminal for Main Power Hookup	90001916	1

Hardware:

#10 x 5/8" Phillips pan head - sensor to bracket	99104002	4
1/4"-14 x 1" Self Drilling Screw- Sensor and Compressor to Frame	99254001	10

The LevelTow Compressor System is an automatic leveling system, once it is turned on (button illuminated blue) it will operate without any assistance.

The Smart sensor supplied with the compressor system will tell the system to inflate or deflate to keep the vehicle level. It has a dwell range built in so that when the truck is going down the road hitting small defects the system will be idle. It isn't until the sensor gets out of this dwell range for 18 seconds that the system will react.

The activation switch has to be illuminated blue for the system to work.



Activation Button

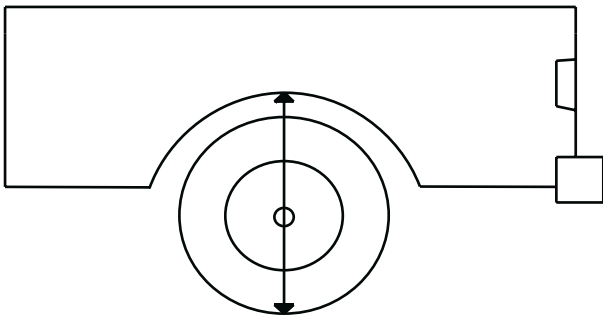

1. Before you install the compressor system, you will need to have the helper Airsprings installed. This will ensure that the LevelTow linkage does not get in the way of the Airsprings.

The first step to doing the install, with the vehicle at ride height, measure the lip of the fender to the ground at the center of the wheel and write it down.

Measurement _____

This measurement will be used as a reference once you have the compressor system installed.

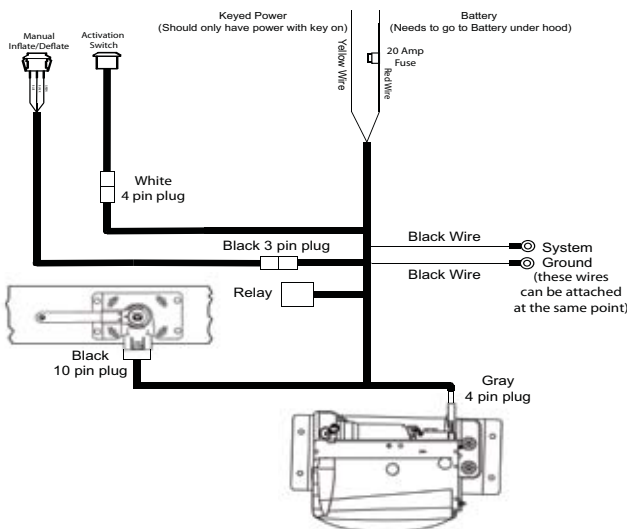

2. Unpack the wiring for the LevelTow system and lay it out. This will give you an idea to where you can mount the components without having to modify the wiring harness.

NOTE:

There is a wiring diagram on Page 7 to assist you in component location.

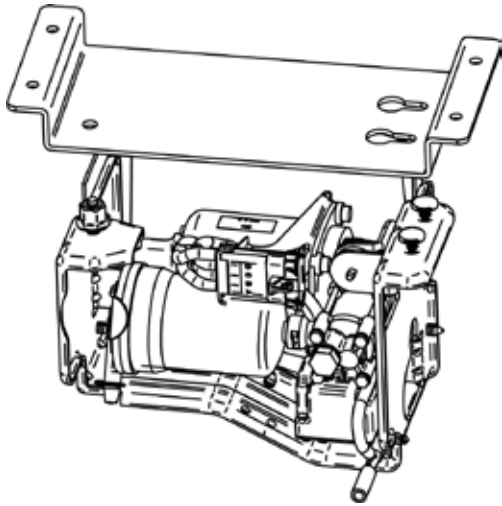

3. Remove the nut from the stud on the compressor that is sticking down. Stick the studs into the holes on the keyhole slots and slide the compressor into the locked position. Reinstall the nut and tighten. Tighten the nuts on the bottom of the studs also. This will secure the compressor to the frame mounting plate.

NOTE:

The diagram shows the position the compressor goes onto the plate.

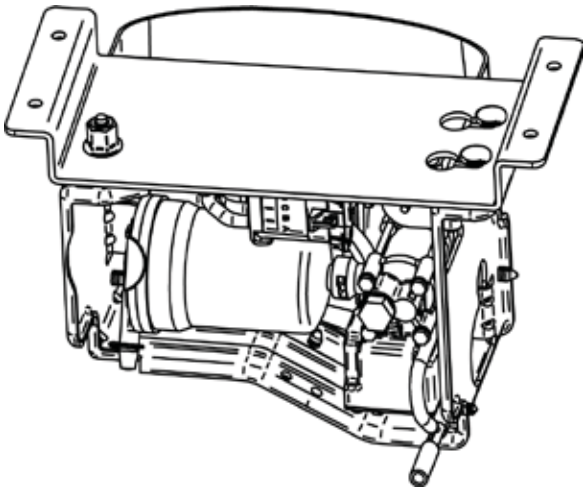

4. With the nuts secured the compressor will be mounted firmly to the plate. The 2 studs will pull down against the mounting plate.

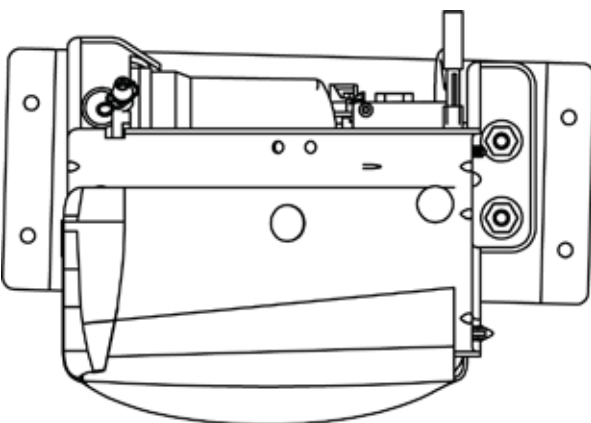

5. The compressor needs to be mounted on the frame rail with the opening up. The rubber shield will protect it from road debris. Attach the compressor bracket to the frame with 4 self drilling screws supplied in the kit.

NOTE:

Before drilling any hole be sure to check and see if there are any brake lines, fuel lines, or wires on the other side of the surface you are drilling.

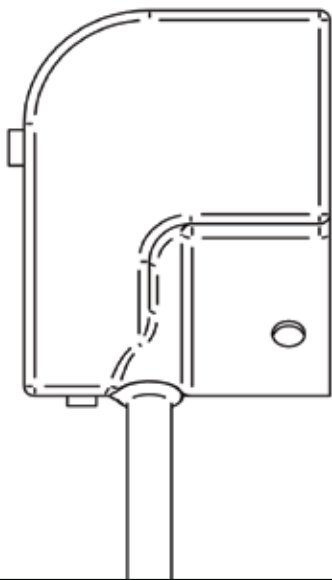

6. The air filter will need to be mounted high on the frame and out of direct tire spray. The hose on the drain should be coming straight out of the bottom. There is a drain in the bottom of the filter housing to drain any water that might get into the housing. Be sure that there are no kinks in the air filter hose leading to the compressor assembly.

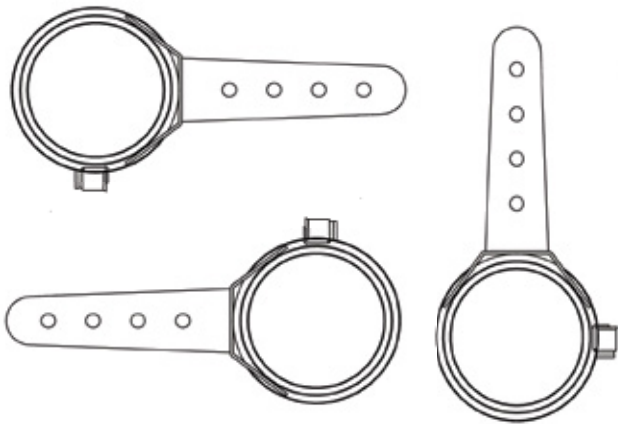

7. The Axle bracket can be mounted in any location on the axle tube to get the sensor linkage to line up. The Axle mount should be mounted on the axle so that the linkage will line up from the axle mount to the sensor. Keep this in mind when establishing the sensor location.

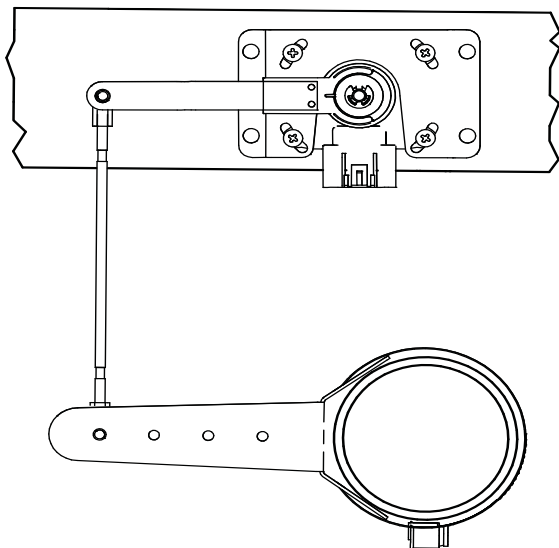

8. The next step will be to mount the sensor. The Smart Sensor needs to be centered in its travel at the trucks ride height to operate properly. This can be done by cutting the linkage rod to length. It can be fine tuned by loosening the 4 sensor mounting screws and twisting it in the mount and retightening the 4 screws. When the mounting and linkage is done it should look like the diagram seen here.

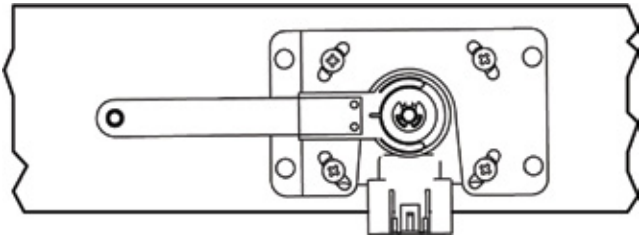

9. The sensor needs to be mounted on the frame rail with the wires pointing down. The arm will need to swing up opposite the direction of the wires as the suspension is being compressed. Attach the sensor bracket to the frame with (4) self drilling screws supplied with the kit.

NOTE:

The sensor can be mounted on the inside or outside of the frame. Make sure the linkage and arm can go through its entire travel without hitting any obstructions

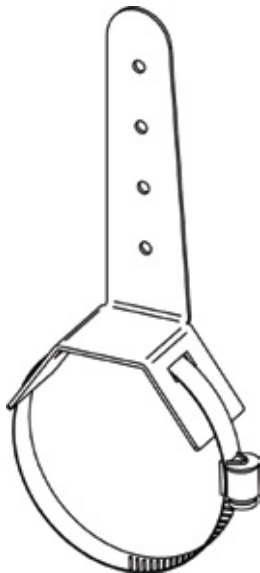

10. This diagram shows how the clamp sticks through the axle bracket. Loosen the clamp until it will open up and then slide it through the bracket. The whole assembly can then be put on the axle tube. Reinsert the end of the clamp back into the adjuster and tighten the clamp until the bracket is tight on the axle tube.



11. With the sensor and the axle bracket mounted, it is time to connect the 2 with the supplied linkage. The linkage is a universal length and will have to be cut to achieve the necessary length for your application. To do this it will be necessary to have the truck sitting at its factory ride height. With the truck at ride height center the sensor in its travel. The rod can slide into each rubber rod end up to 1".

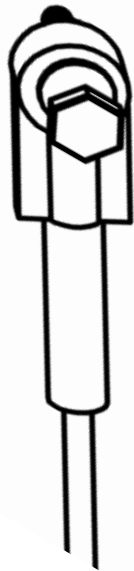

12. The 2 pieces of heat shrink supplied in the kit will hold the linkage together after your length is determined. To apply the heat shrink slide one piece over the rubber endlink as far as it will go on to the rod side. Heat the heat shrink **at the rubber end first** with a heat gun(hair dryer or small torch will work) until it shrinks down to the rubber. Continue heating the heat shrink to the rod until secured. Be sure not to over heat the tubing causing it to pull from the rubber end.

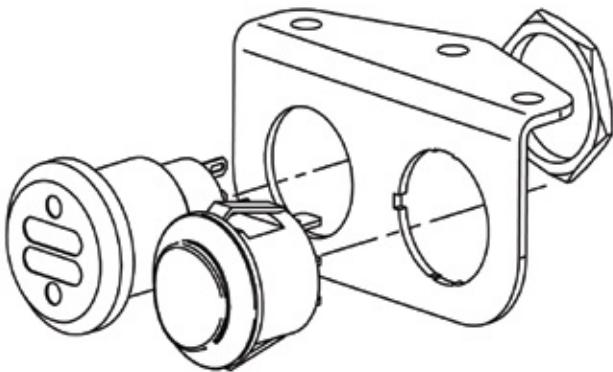

13. Mount the control panel in a convenient location. Install the Power Button and Manual Control Rocker into the panel. The Power Button gets installed into the round hole. The nut that is on the button is used to attach the button in the panel. The Rocker Switch goes into the hole with the notch in it. Align the tab on the switch with the slot and push the switch into the hole until it snaps in place. The rocker will only go into the hole one way. You can also custom mount the buttons if desired. They both use a 3/4" hole. The hole for the manual switch will have to have a slot for the tab

TOP

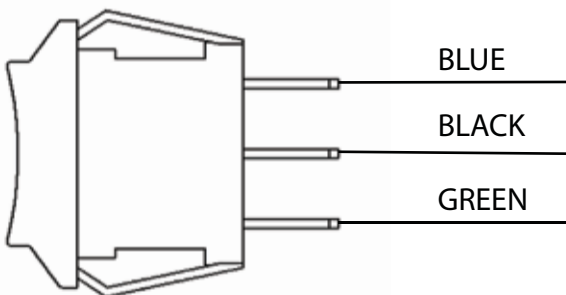

14. Hook the wires up to the manual control switch as shown in the diagram.

Green Wire-Manual Inflate
Black Wire -Switch Supply
Blue Wire - Manual Deflate

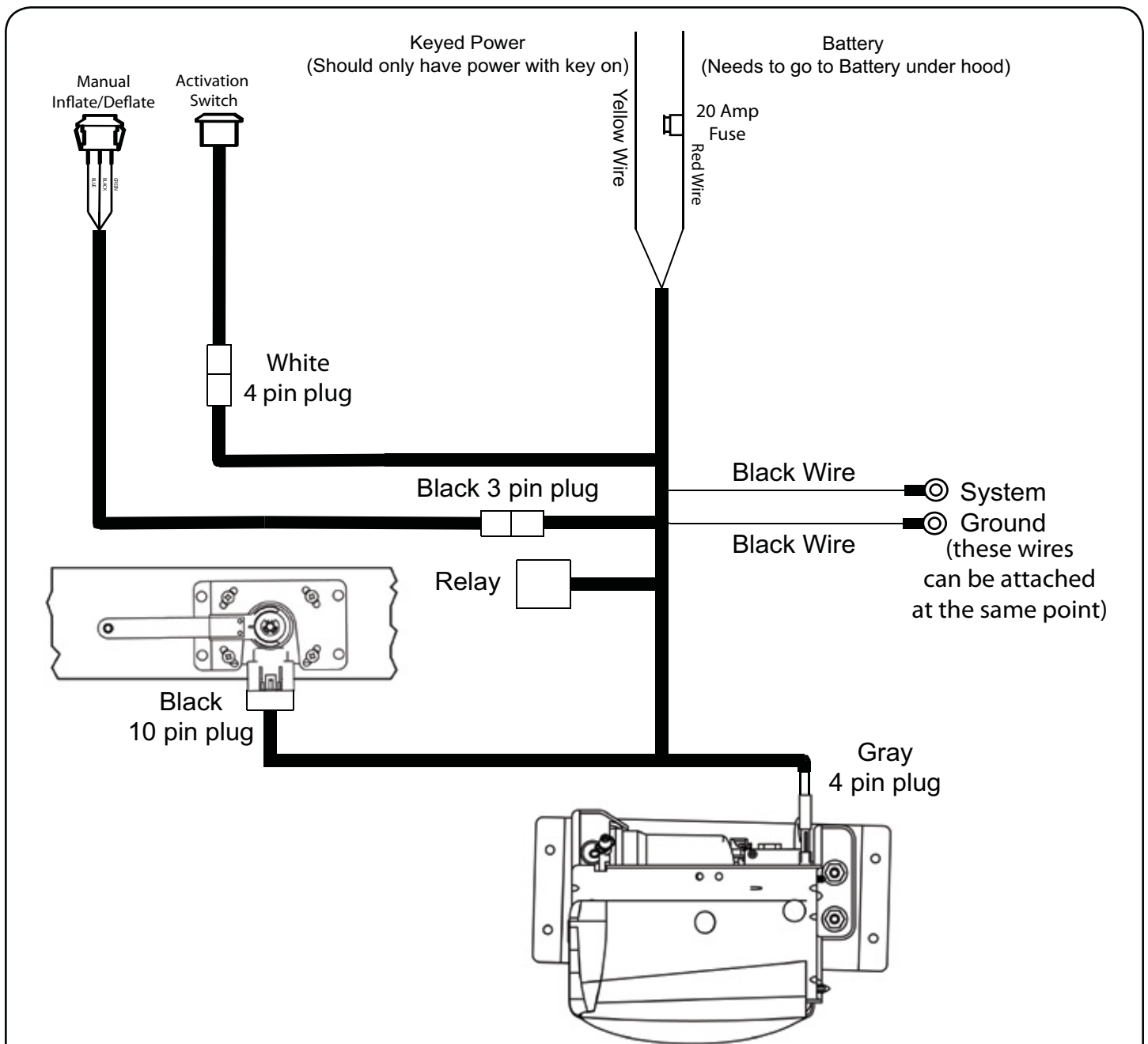

Red Wire - This wire needs to go straight to the **Battery** with the fuse holder installed within 18" of the Battery

Yellow Wire - This wire needs to go to a switched 12 volt power source. This wire should only have power when the key is on.

Black Wires - These wires go to a chassis ground. They can go to one of the screws attaching the compressor to the frame.

Relay - Will need to be attached to the frame with a self drilling screw supplied in the kit..

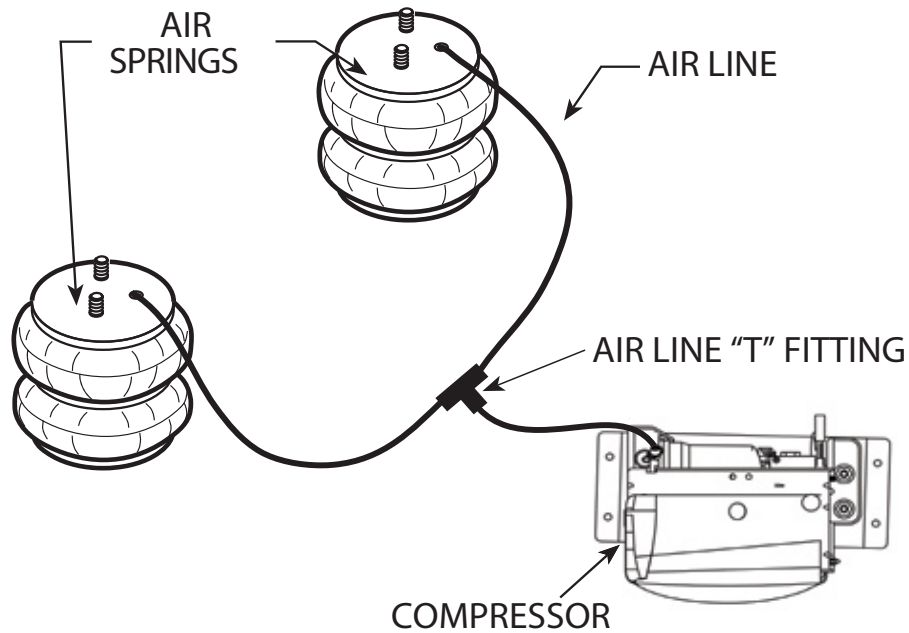

15. **Uncoil the airline being careful not to kink or flatten the line.** Start at the Airspring furthest from the compressor. Trim the airline so that the cut is clean and as square as possible. Insert the end of the airline into the fitting pushing it in as far as possible. Route the airline from the airspring to the compressor keeping it away the exhaust pipe and sharp edges. If it is necessary to run the line over a sharp edge, use a supplied thermal sleeve over the airline to protect it. The sleeve is installed by sliding it over the airline to the area where the line needs protected. **The airline should not be bent or curved sharply, this can cause the line to buckle or kink.** Secure the airline in place using the Zipties provided in the kit. Once the first airspring line is ran to the compressor, trim off the excess and use it for the remaining air spring line to the compressor. With both lines ran from the air spring to the compressor, install the "T" fitting on the lines and run the remaining side of the "T" fitting to the compressor fitting.

TIP: Wetting the end of the airline before sliding it into the fitting makes it easier to install into the fitting.

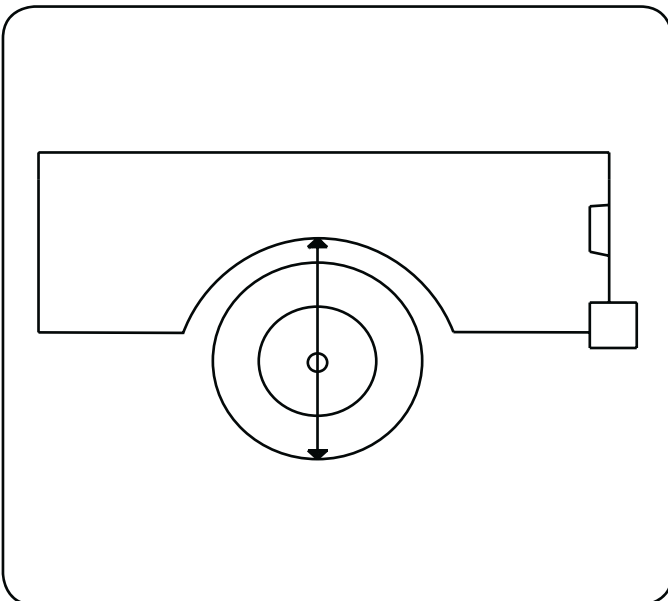

16. Once the system is installed you can verify the operation of the system by putting a load on the truck. With a load on the truck and the button illuminated blue, your fender to ground measurement that you took on the first step should be the same. If it is higher or lower you can adjust the height by loosening the 4 screws that attach the sensor to the bracket and twist in its mount. If ride height can not be achieved by adjusting in the bracket the linkage will need to be lengthened or shortened to achieve the height you need.

Manual Operation:

The LevelTow Compressor System also has a manual control function. This function allows you to manually inflated or deflate the system. To use the manual function you must first turn the system off by pushing the main power button. Once the system is turned off you can push the rocker switch up to inflate or down to deflate. To put the system back in level mode push the main power switch to turn it back on.

Note:

If the Activation Button is illuminated blue and the manual button is pushed the truck will relevel itself. The activation button has to be off for the manual control to be used and the truck remain at the height.

Troubleshooting:

If after installation you find the system not functioning correctly, you may have the sensor operating the wrong direction. You can verify this by turning the truck on and check that the activation button is illuminated blue. Unhook one end of the linkage and move the sensor arm by hand. If when you move the arm down (Keep in mind there is an 20 second delay) and the Air spring inflates, the sensor is operating in the wrong direction. You can fix this problem without remounting the sensor by swapping the blue and green wires in the harness at the sensor. To do this, with the truck turned off, simply unplug the harness from the sensor. Using a small screwdriver pop the purple retainer out of the plug by prying up on each end of it. After removing the retainer if you look into the end of the plug you will see a tang holding each wire terminal. Simply pry it down just enough to release the terminals of the blue and green wires. Swap the blue and green wire position and reinstall the wires into the plug paying attention to the direction of the small tab on the wire terminal. This tab will point to the center of the plug. Push the wire terminals into the plug making sure they catch on the tang and reinstall the purple retainer. After plugging the sensor back in you can confirm correct operation by turning the truck back on moving the sensor arm up, the Air spring should inflate. If the system is functioning correctly, shut the truck off and reattach the linkage.

