

LevelTOW

ADVANCED TOWING SOLUTIONS
by ridetech

99-04 Ford F250, F350 Super Duty 2WD & 4WD

Congratulations - your new LevelTow [Helper Springs](#) are quality products capable of improving the handling and comfort of your vehicle. As with all products, proper installation is the key to obtaining all of the benefits your kit is capable of delivering. Please take a few minutes to read through the instructions to identify the components and learn where and how they are used. It is a good idea to start by comparing the parts in your kit with the parts list below.

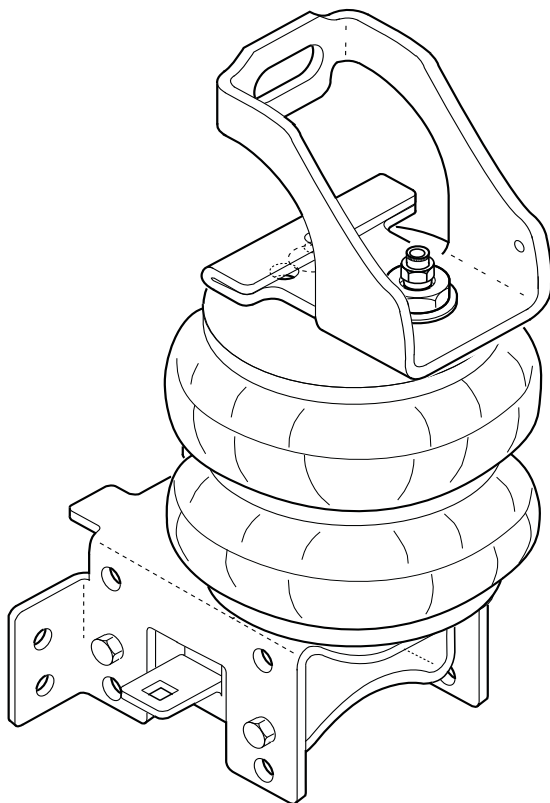

Components

224C AIR SPRING	6401	2
UPPER BRACKET	5572	2
LOWER BRACKET	5380	2
SADDLE BRACKET	5379	2
FUEL LINE BRACKET	5428	1
AXLE STRAP	1163	2
1/2" SPACER	5477	2
HEAT SHIELD	1004	1
BAIL CLAMP	3077	2

Hardware

THERMAL SLEEVE	2
TIE-WRAPS	6
5/16"-24 X 3/4" HEX HEAD BOLT	1
5/16"-24 FLANGE HEAD NUT	1
5/16" FLAT WASHER	4
3/8"-16 X 3/4" FLANGE HEAD BOLT	2
3/8"-16 X 1" HEX HEAD BOLT	8
3/8"-16 X 2-1/2" FLAT HEAD BOLT	2
3/8"-16 X 3" CARRIAGE BOLT	4
3/8"-16 FLANGE HEAD NUT	18
3/8" LARGE FLAT WASHER	2
3/4"-16 X 3" HEX HEAD BOLT	2
3/4"-16 X 1-3/4" HEX HEAD BOLT	2
3/4"-16 HEX HEAD NUT	4
3/4"-16 FRAME NUT	2
3/4" INTERNAL TOOTH LOCKWASHER	2
3/4" LOCK WASHER	2
3/4" FLAT WASHER	8
3/4" THICK FLAT WASHER	2

WARNING!

Do not inflate this assembly when it is unrestricted. The assembly must be restricted by the suspension or other adequate structure. Do not inflate beyond 100 P.S.I. Improper use or over inflation may cause property damage or severe personal injury.

1999-2004 Trucks

Figure "A"

Find the closest point between the exhaust pipe and the air spring. Mount the heat shield in this location.

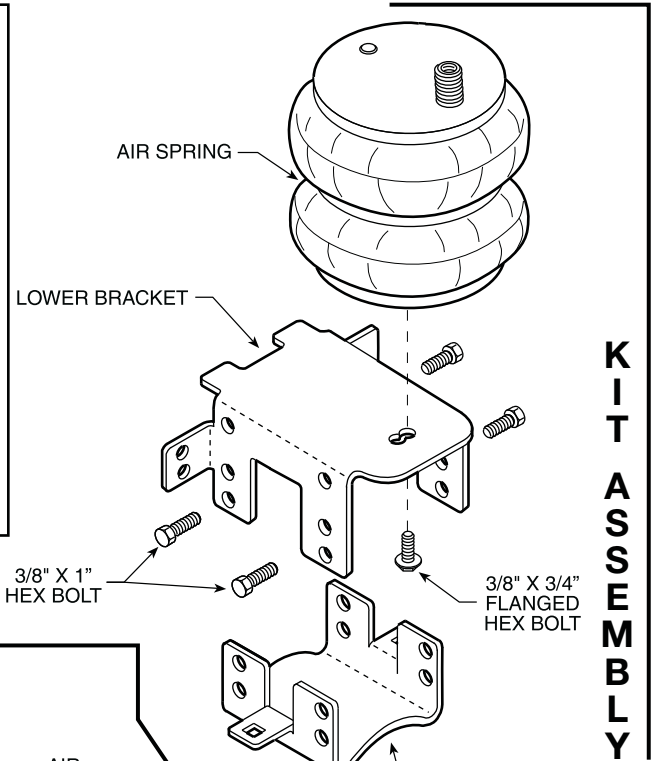
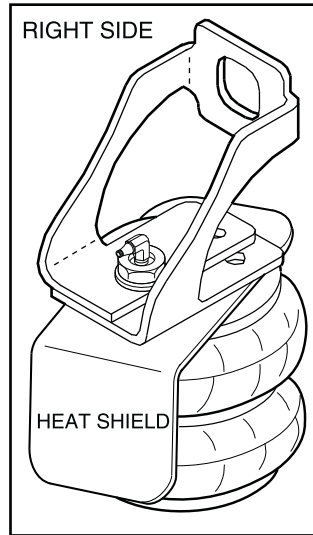

KIT ASSEMBLY

NOTE: This diagram is of the left side of the truck. Reverse any orientations when assembling and installing the right side of the vehicle.

KIT TO FRAME ASSEMBLY

⚠ See Figure "B" for Upper Bracket mounting. ⚠

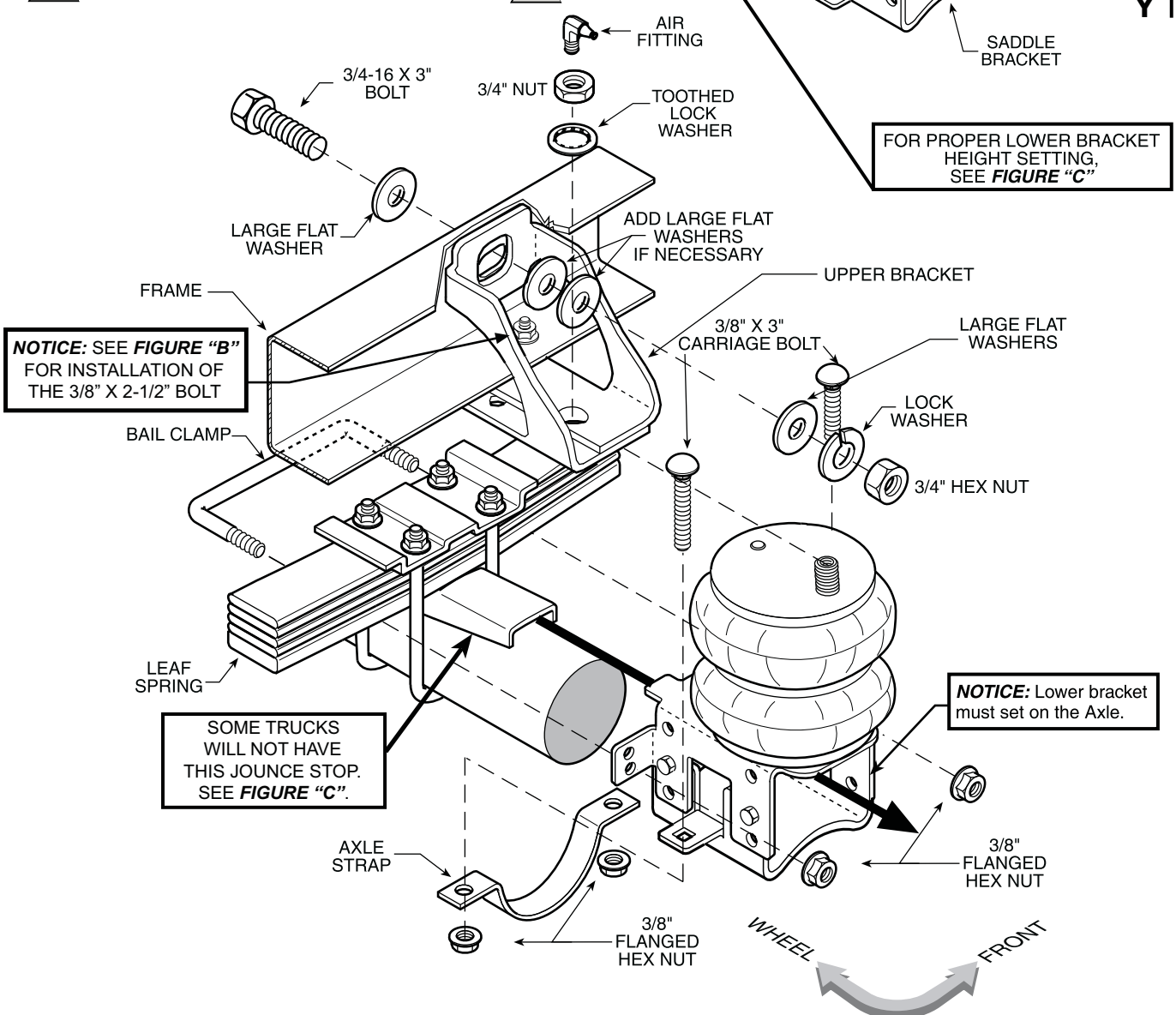

**2008–2010 Gasoline and Diesel Trucks
2011+ Gasoline Trucks**

Figure "A"

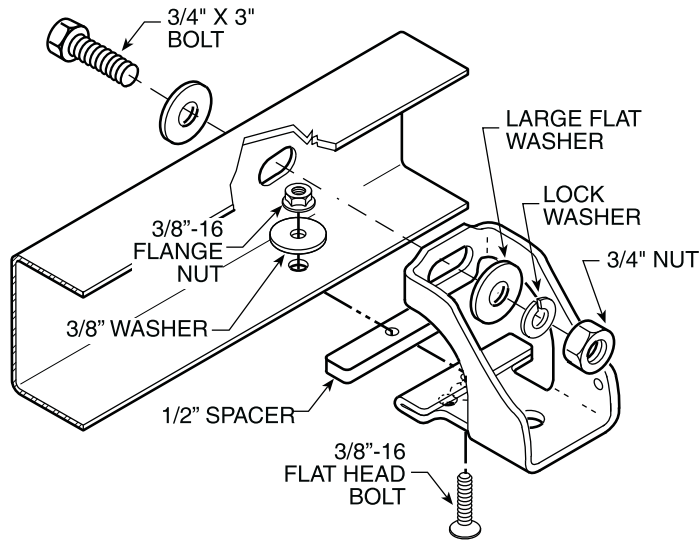

UPPER BRACKET ATTACHMENT

KIT TO FRAME ASSEMBLY

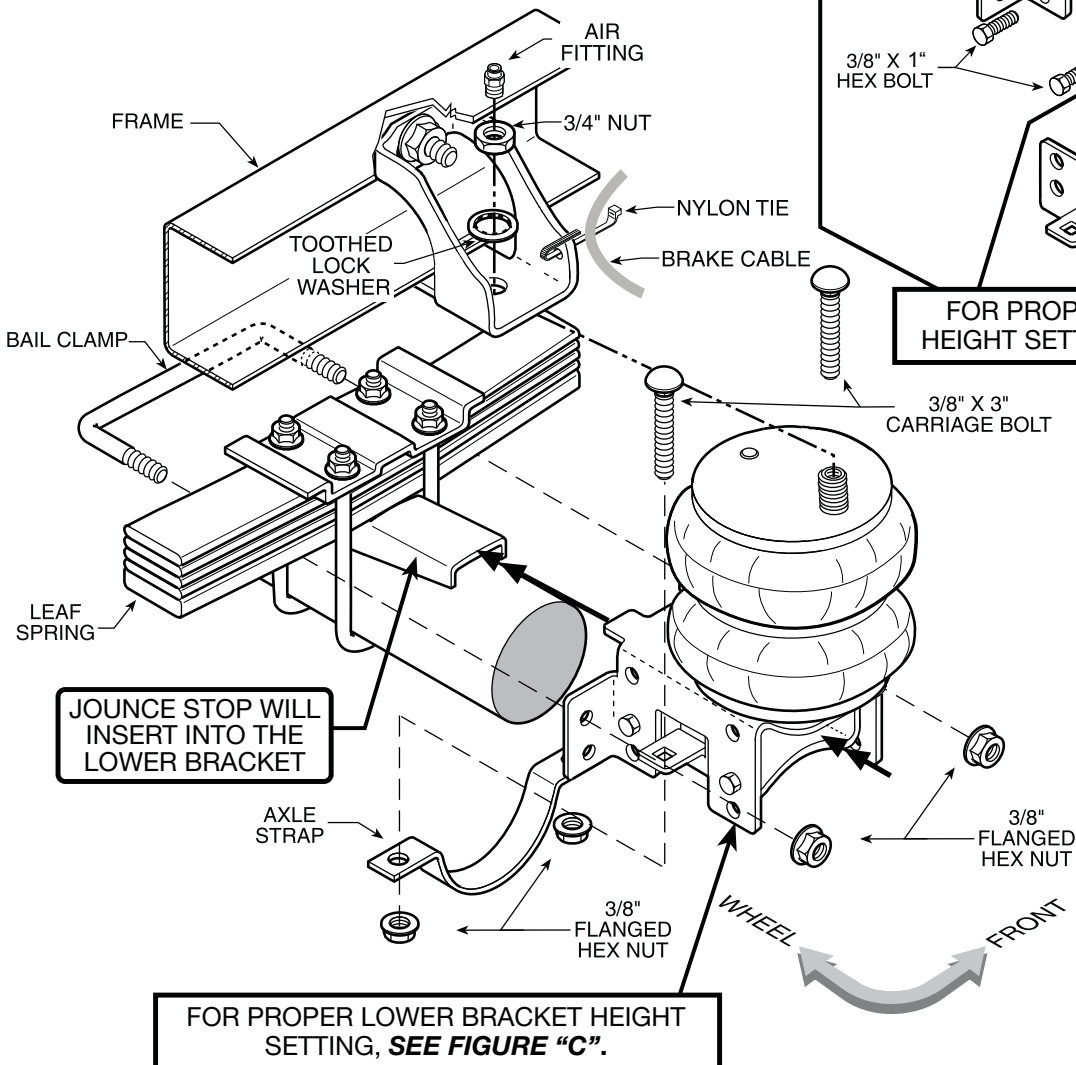

Note: This diagram is of the left side of the truck. Reverse any orientations when assembling and installing the right side of the vehicle.

KIT ASSEMBLY

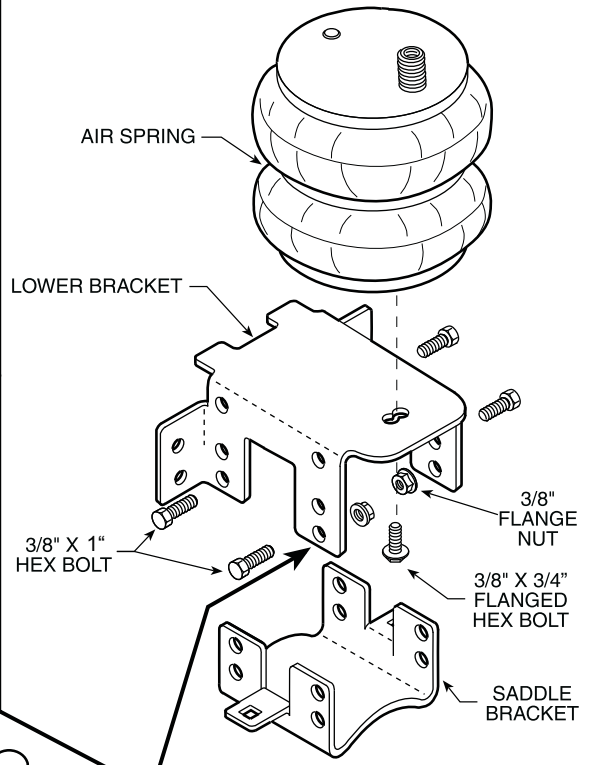

FOR PROPER LOWER BRACKET HEIGHT SETTING, SEE FIGURE "C".

2011+ Gasoline Trucks with In-Bed Factory Hitch

Figure "A"

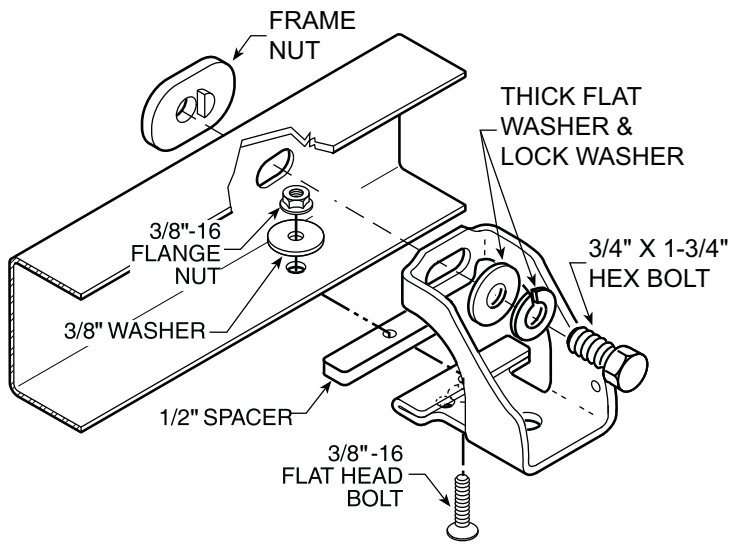

UPPER BRACKET ATTACHMENT

KIT TO FRAME ASSEMBLY

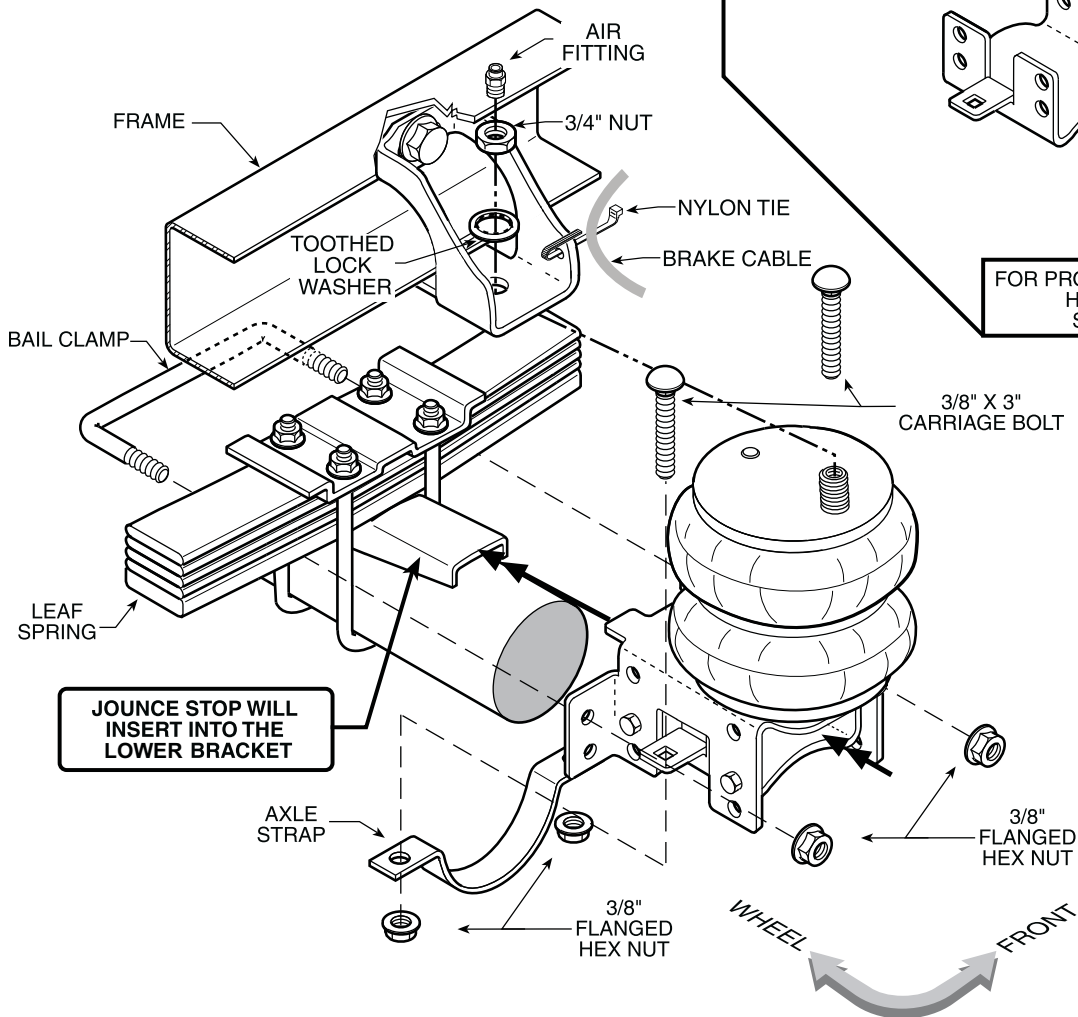

JOUNCE STOP WILL INSERT INTO THE LOWER BRACKET

Note: This diagram is of the left side of the truck. Reverse any orientations when assembling and installing the right side of the vehicle.

KIT ASSEMBLY

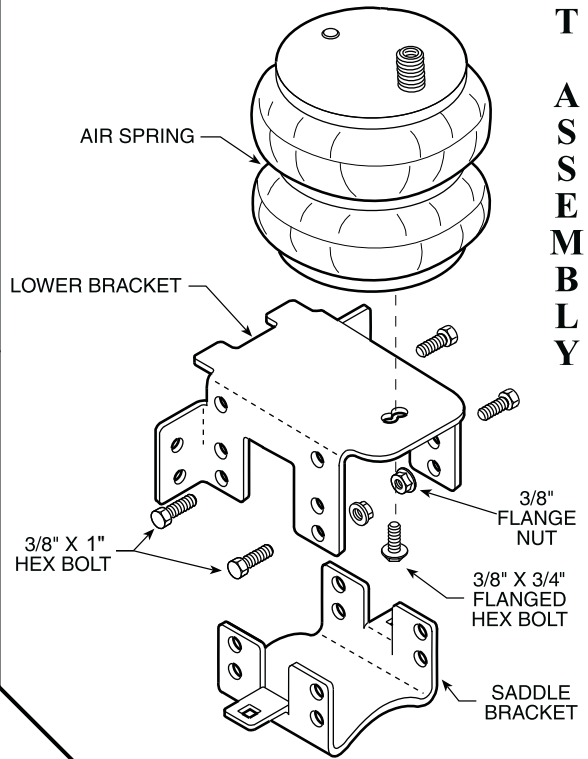

FOR PROPER LOWER BRACKET HEIGHT SETTING, SEE FIGURE "C"

STEP 1—PREPARE THE VEHICLE

Place the truck on a solid level surface. Remove the negative battery cable. Take necessary safety precautions such as using wheel chocks when working on your truck.

On some 2008 and newer trucks some lines must be repositioned on the left side of the vehicle. Remove the nut holding the fuel line retaining clip. Rotate the retaining clip 90 degrees with the stud facing down. Install the relocation bracket with the nut previously removed. Next fasten the retaining clip to the relocation bracket using a 5/16"-24 x 3/4" bolt and 5/16"-24 flange nut.

Your truck is equipped with jounce bumpers attached to the frame directly above the axle. Remove these bumpers by unbolting from the inside of the frame flange. These bumpers will not be re-used with this kit. For vehicles from 1999 to 2004 please save the collar as it will be re-used in Step 2B.

STEP 2A—UPPER BRACKET INSTALLATION FOR 2008 AND UP TRUCKS

Insert the 3/8"-16 x 2-1/2" flat head bolt into the upper bracket and then slide the spacer over the bolt. Install the upper bracket onto the frame. Make sure that no part of the vehicle's wiring will be pinched between the upper bracket and the frame. Tighten the 3/8"-16 flat head bolt with a 3/8" large flat washer and 3/8"-16 flange nut. The emergency brake cable will have to be tie-wrapped out of the way using the hole provided in the upper bracket. **See Figure "A"**.

On trucks without factory installed in-bed hitch, install the 3/4"-16 x 3" hex bolt through the existing hole in the frame rail and upper bracket. Secure the 3/4"-16 x 3" bolt with a 3/4" flat washer, 3/4" lock washer and a 3/4"-16 hex nut.

On truck with a factory installed in-bed hitch, install the 3/4"-16 x 1-3/4" hex bolt through the existing hole in the frame rail and upper bracket. Secure the 3/4"-16 x 1-3/4" bolt with a 3/4" thick flat washer, 3/4" lock washer and a 3/4"-16 flange nut.

STEP 2B—UPPER BRACKET INSTALLATION FOR 1999 TO 2004 TRUCKS

Make sure that no part of the vehicle's wiring will be pinched between the upper bracket and the frame. At this time, the collar that was on the jounce bumper will be reused. Insert the collar into the original hole on the frame. Put the upper bracket in place (to hold the collar) while you insert the 3/8"-16 x 2-1/2" flat head bolt into the upper bracket and collar. **See Figure "B"**. Secure the 3/8"-16 flat head bolt with a 3/8" large flat washer and 3/8"-16 flange nut finger tight.

Hold the upper bracket tight against the bottom of the frame. If the bracket appears to be level with the upper part of the bracket rests against the inside of the frame, install the 3/4"-16 x 3" bolt through the frame rail and upper bracket. If the top of the bracket does not set level, install some of the large 3/4" flat washers between the bracket and the inside of the frame rail. If you have existing hitch hardware, the 3/4" bolt should be long enough to extend through the upper bracket, truck frame and hitch brackets. Be sure to install at least one of the large flat washers and the 3/4" lock washer before installing the 3/4"-16 hex nut onto the bolt. After you have installed the upper bracket as level as possible, tighten the 3/8"-16 x 2 1/2" flat head bolt in the bottom of the frame, then tighten the 3/4"-16 x 3" bolt through the side of the frame. The emergency brake cable will have to be tie-wrapped out of the way using the hole provided in the upper bracket. **See Figure "A"**.

STEP 3—AIR SPRING INSTALLATION

The heat shield will be used on the exhaust side of the truck only. It is placed between the upper bracket and the top of the air spring. **See Figure "B"**. The alignment pin on top of the air spring **must** be aligned with the hole in the upper bracket

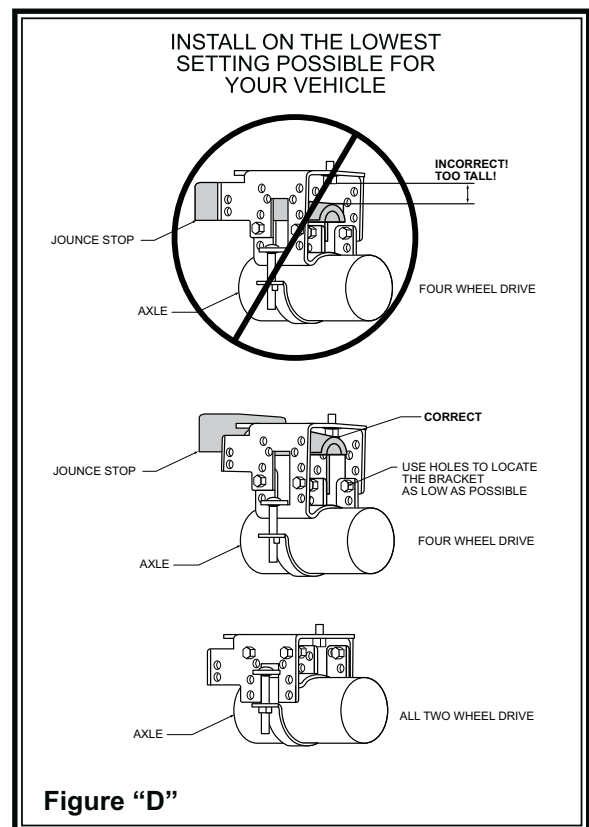
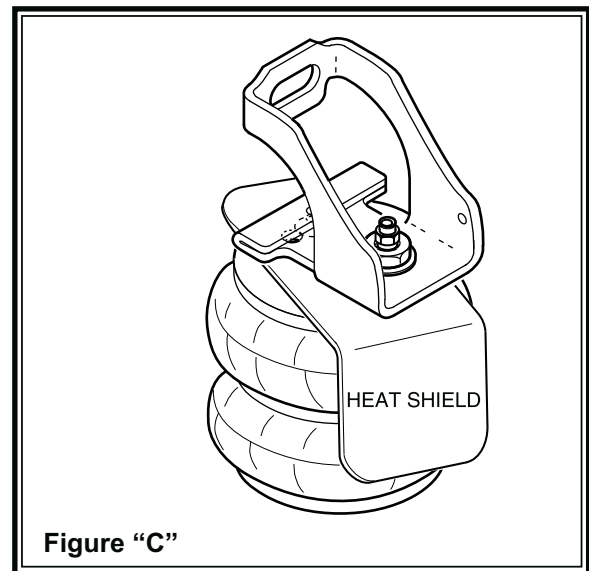
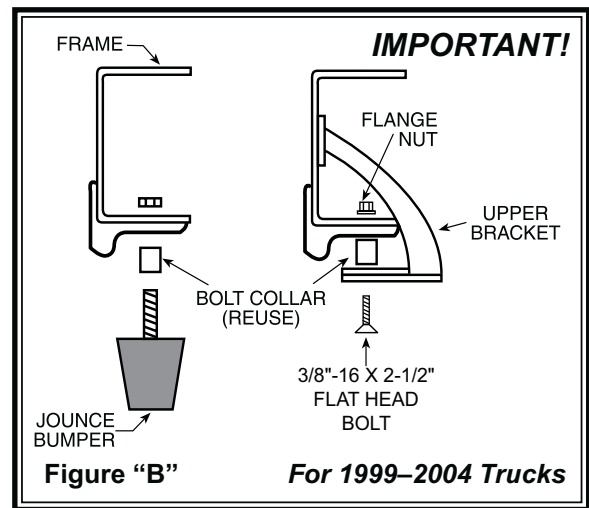

towards the front of the truck, on both sides. When the air spring is in place and properly aligned, install the internal tooth lock washer and 3/4"-16 hex nut onto the stud of the air spring. On the right side, align the heat shield before tightening the 3/4"-16 hex nut on the air spring. Make sure the heat shield will not interfere with the normal operation of the air spring or the vehicle's suspension. Do not position the face of the directly over the axle, as it may contact the axle on full suspension compression. Next install the air fitting into the stud of the air spring. Tighten the air fitting securely to engage the orange thread sealant.

STEP 4—LOWER BRACKET INSTALLATION

Four wheel drive trucks will have a cast iron jounce stop as shown in **Figures "A" and "C"**. If this jounce stop is present, the height setting of the lower bracket assembly needs to be just above the jounce stop (to clear the head of the bolt in the bottom of the air spring). On two wheel drive trucks assemble the lower assembly to the shortest setting. **See Figure "D"**.

The lower bracket assembly should be installed on the lowest setting possible for the truck. See Figure "D".

The saddle and lower bracket are bolted together using four 3/8"-16 x 1" bolts and flange nuts to make up the lower bracket assembly. When the assembly is bolted together at the proper height, install the 3/8"-16 x 3/4" flange blot through the forward hole on the lower bracket into the bottom of the air spring and tighten.

Place the lower bracket assembly against the leaf spring stack making sure that the top of the lower bracket fits in between the axle U-bolts. Place the bail clamp around the axle block and install the 3/8"-16 flange nuts onto the bail clamp and tighten.

Insert the carriage bolts through the square holes on the lower bracket assembly being careful not to chaff or pinch the brake lines on the axle. Next push the axle strap onto the bottom of the axle and through the carriage bolts. When the 3/8"-16 flange nuts are tightened, they will draw the axle strap into place.

COMBO STUD NOTICE:

THE ALIGNMENT PIN ON THE AIR SPRING **MUST** BE INSTALLED INTO THE HOLE IN THE UPPER BRACKET.

FAILURE TO DO SO WILL CAUSE THE ALIGNMENT PIN TO BE PUSHED INTO THE BEAD PLATE, CREATING AN AIR LEAK, AND RESULTING IN AN AIR SPRING FAILURE THAT IS **NOT WARRANTABLE.**

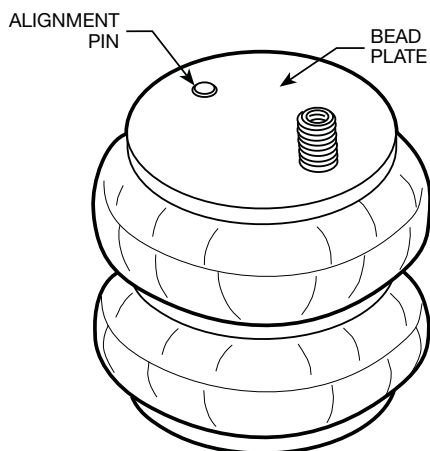

Important:

In order for the air spring to function properly, there must be a minimum of 1/2" of clearance around the air spring.



LevelTOW

ADVANCED TOWING SOLUTIONS
by ridetech

LevelTow Compressor System

Congratulations - your new LevelTow Compressor System is a quality product, that when used in conjunction with the LevelTow helper Air Springs, is capable of improving the handling and comfort of your vehicle. As with all products, proper installation is the key to obtaining all of the benefits your kit is capable of delivering. Please take a few minutes to read through the instructions to identify the components and learn where and how they are used. It is a good idea to start by comparing the parts in your kit with the parts list below.

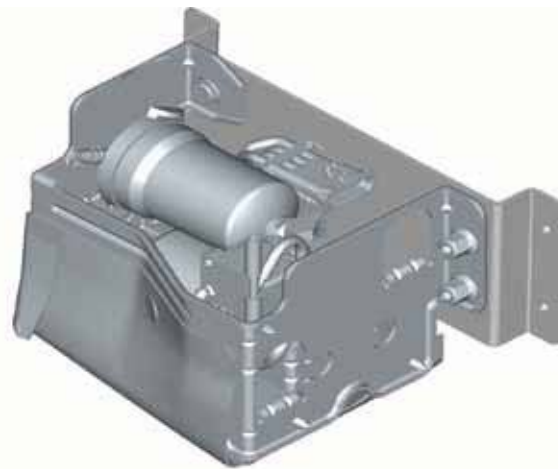
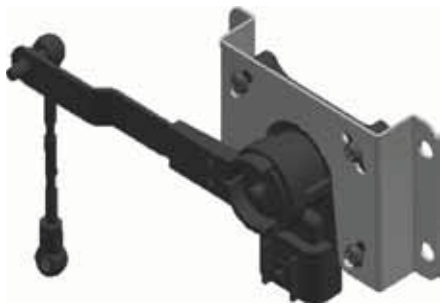

Components:

	Part #	QTY
Compressor Unit	31920012	1
Smart Sensor Height Sensor	70010596	1
Compressor Mounting Bracket	90002440	1
Smart Sensor Mounting Bracket	70010596	1
Sensor Linkage	31980001	1
Linkage Axle Bracket	70011429	1
Control Panel Bracket	70011439	1
Airline Adapter (mounted to compressor)	70011436	1
Airline Cartridge Fitting (mounted in compressor)	31954500	1
Main Activation Switch	35970000	1
Manual Control Switch	70011413	1
Main Wire Harness	31900051	1
Axle Bracket Clamp	99000005	1
1/4" TEE Fitting	31954400	1
1/4" Fitting for airsprings Straight / 90 Degree	31954000 / 31954201	2
Heat Shrink tubing for Sensor linkage	90002030	2
20 amp fuse	90001922	1
Fuse Holder	90001924	1
10-12 Butt Connector for Fuse Holder	90001913	1
Ring Terminal for Main Power Hookup	90001916	1

Hardware:

#10 x 5/8" Phillips pan head - sensor to bracket	99104002	4
1/4"-14 x 1" Self Drilling Screw- Sensor and Compressor to Frame	99254001	10

The LevelTow Compressor System is an automatic leveling system, once it is turned on (button illuminated blue) it will operate without any assistance.

The Smart sensor supplied with the compressor system will tell the system to inflate or deflate to keep the vehicle level. It has a dwell range built in so that when the truck is going down the road hitting small defects the system will be idle. It isn't until the sensor gets out of this dwell range for 18 seconds that the system will react.

The activation switch has to be illuminated blue for the system to work.



Activation Button

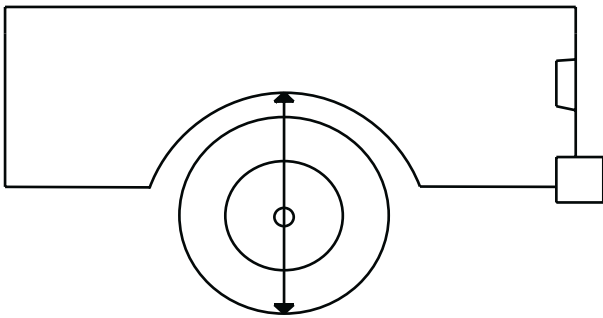

1. Before you install the compressor system, you will need to have the helper Airsprings installed. This will ensure that the LevelTow linkage does not get in the way of the Airsprings.

The first step to doing the install, with the vehicle at ride height, measure the lip of the fender to the ground at the center of the wheel and write it down.

Measurement _____

This measurement will be used as a reference once you have the compressor system installed.

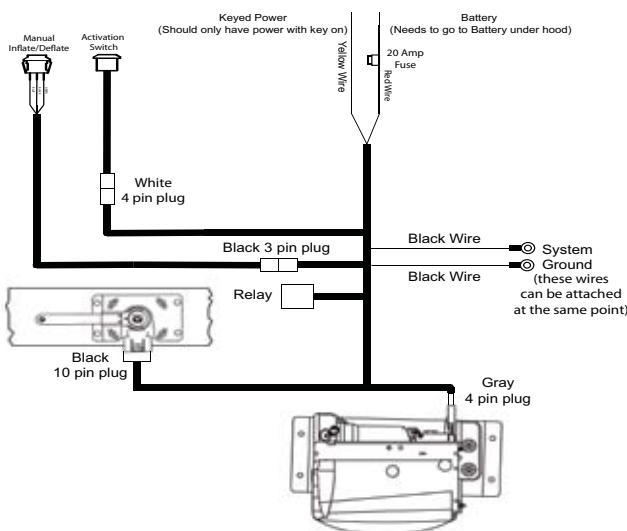

2. Unpack the wiring for the LevelTow system and lay it out. This will give you an idea to where you can mount the components without having to modify the wiring harness.

NOTE:

There is a wiring diagram on Page 7 to assist you in component location.

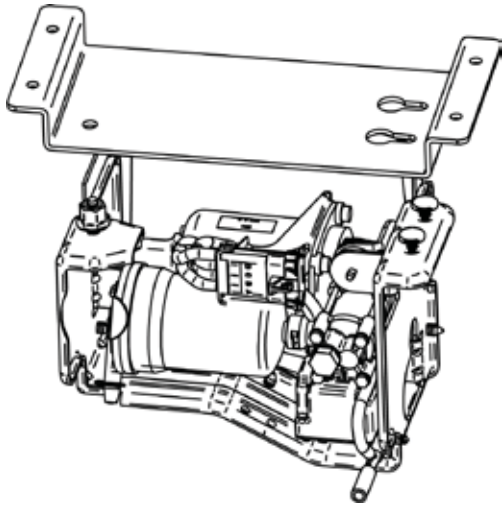

3. Remove the nut from the stud on the compressor that is sticking down. Stick the studs into the holes on the keyhole slots and slide the compressor into the locked position. Reinstall the nut and tighten. Tighten the nuts on the bottom of the studs also. This will secure the compressor to the frame mounting plate.

NOTE:

The diagram shows the position the compressor goes onto the plate.

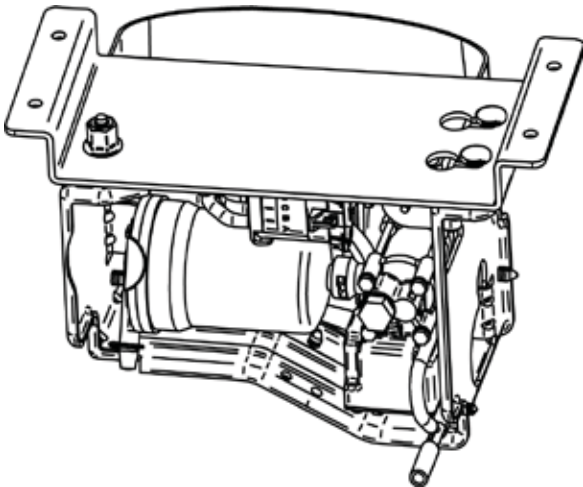

4. With the nuts secured the compressor will be mounted firmly to the plate. The 2 studs will pull down against the mounting plate.

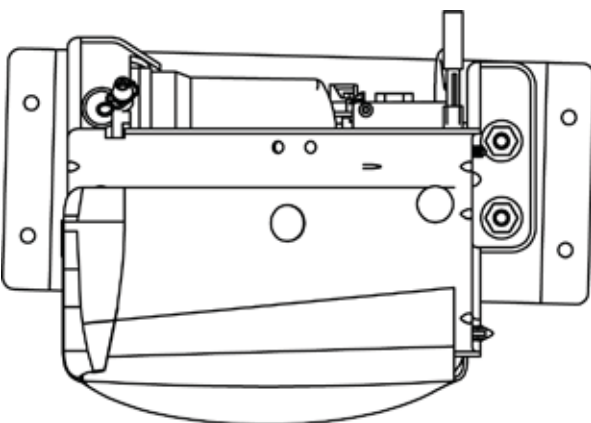

5. The compressor needs to be mounted on the frame rail with the opening up. The rubber shield will protect it from road debris. Attach the compressor bracket to the frame with 4 self drilling screws supplied in the kit.

NOTE:

Before drilling any hole be sure to check and see if there are any brake lines, fuel lines, or wires on the other side of the surface you are drilling.

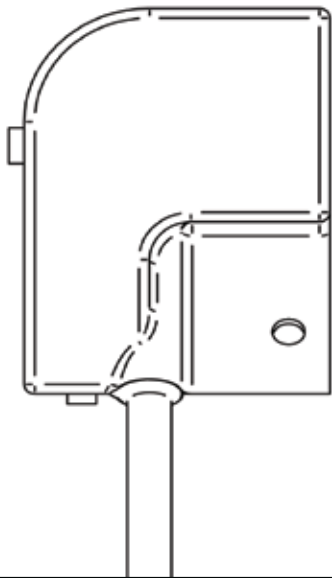

6. The air filter will need to be mounted high on the frame and out of direct tire spray. The hose on the drain should be coming straight out of the bottom. There is a drain in the bottom of the filter housing to drain any water that might get into the housing. Be sure that there are no kinks in the air filter hose leading to the compressor assembly.

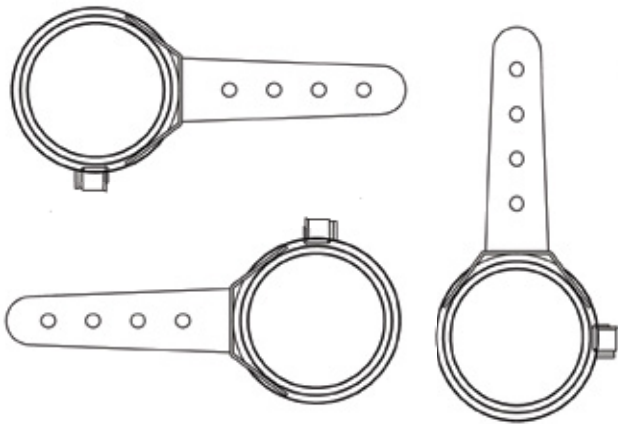

7. The Axle bracket can be mounted in any location on the axle tube to get the sensor linkage to line up. The Axle mount should be mounted on the axle so that the linkage will line up from the axle mount to the sensor. Keep this in mind when establishing the sensor location.

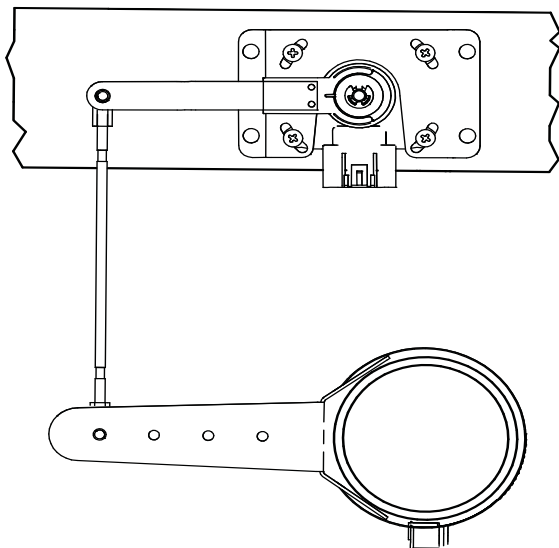

8. The next step will be to mount the sensor. The Smart Sensor needs to be centered in its travel at the trucks ride height to operate properly. This can be done by cutting the linkage rod to length. It can be fine tuned by loosening the 4 sensor mounting screws and twisting it in the mount and retightening the 4 screws. When the mounting and linkage is done it should look like the diagram seen here.

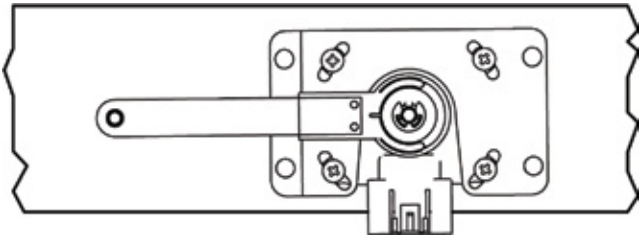

9. The sensor needs to be mounted on the frame rail with the wires pointing down. The arm will need to swing up opposite the direction of the wires as the suspension is being compressed. Attach the sensor bracket to the frame with (4) self drilling screws supplied with the kit.

NOTE:

The sensor can be mounted on the inside or outside of the frame. Make sure the linkage and arm can go through its entire travel without hitting any obstructions

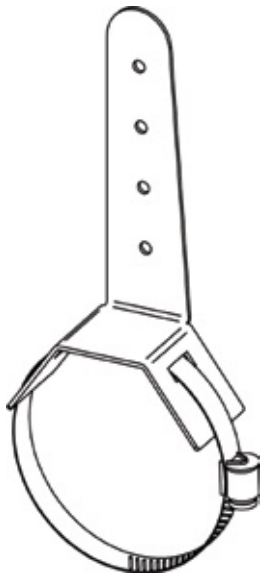

10. This diagram shows how the clamp sticks through the axle bracket. Loosen the clamp until it will open up and then slide it through the bracket. The whole assembly can then be put on the axle tube. Reinsert the end of the clamp back into the adjuster and tighten the clamp until the bracket is tight on the axle tube.

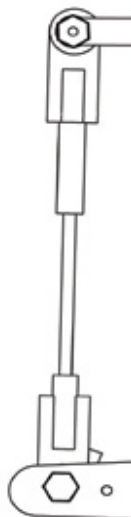

11. With the sensor and the axle bracket mounted, it is time to connect the 2 with the supplied linkage. The linkage is a universal length and will have to be cut to achieve the necessary length for your application. To do this it will be necessary to have the truck sitting at its factory ride height. With the truck at ride height center the sensor in its travel. The rod can slide into each rubber rod end up to 1".

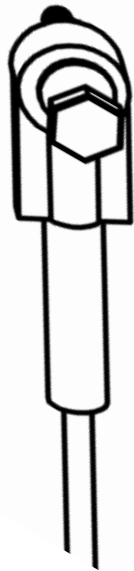

12. The 2 pieces of heat shrink supplied in the kit will hold the linkage together after your length is determined. To apply the heat shrink slide one piece over the rubber endlink as far as it will go on to the rod side. Heat the heat shrink **at the rubber end first** with a heat gun(hair dryer or small torch will work) until it shrinks down to the rubber. Continue heating the heat shrink to the rod until secured. Be sure not to over heat the tubing causing it to pull from the rubber end.

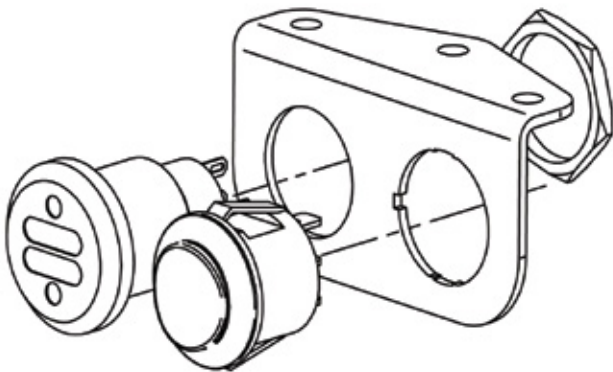

13. Mount the control panel in a convenient location. Install the Power Button and Manual Control Rocker into the panel. The Power Button gets installed into the round hole. The nut that is on the button is used to attach the button in the panel. The Rocker Switch goes into the hole with the notch in it. Align the tab on the switch with the slot and push the switch into the hole until it snaps in place. The rocker will only go into the hole one way. You can also custom mount the buttons if desired. They both use a 3/4" hole. The hole for the manual switch will have to have a slot for the tab

TOP

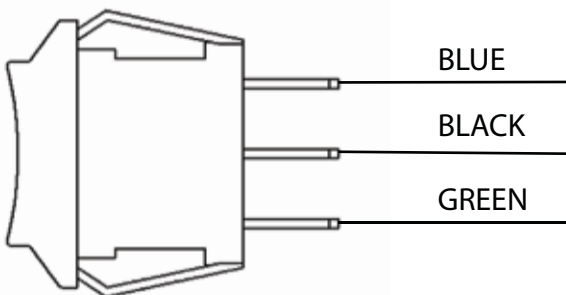

14. Hook the wires up to the manual control switch as shown in the diagram.

Green Wire-Manual Inflate
Black Wire -Switch Supply
Blue Wire - Manual Deflate

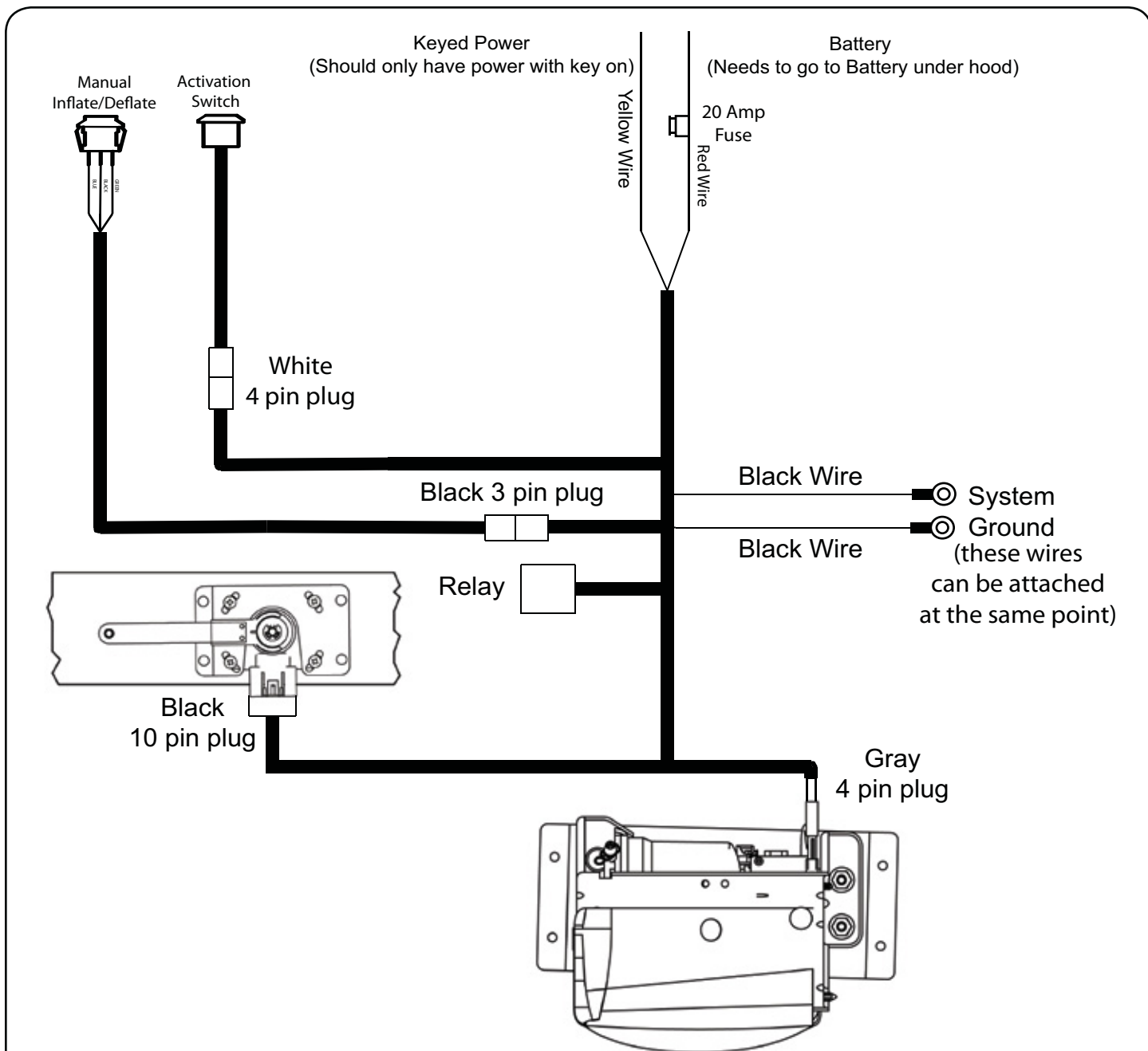

Red Wire - This wire needs to go straight to the **Battery** with the fuse holder installed within 18" of the Battery

Yellow Wire - This wire needs to go to a switched 12 volt power source. This wire should only have power when the key is on.

Black Wires - These wires go to a chassis ground. They can go to one of the screws attaching the compressor to the frame.

Relay - Will need to be attached to the frame with a self drilling screw supplied in the kit..

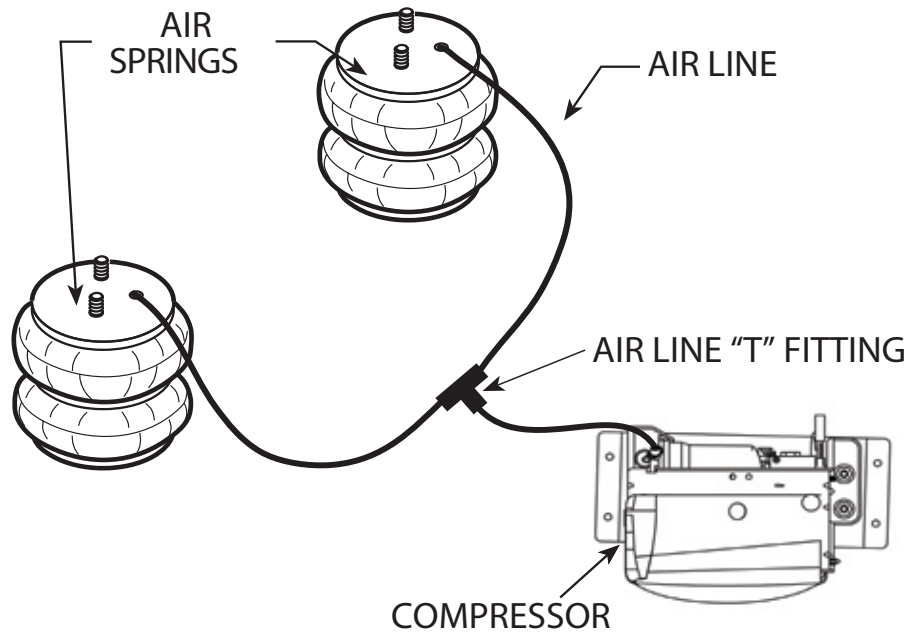

15. **Uncoil the airline being careful not to kink or flatten the line.** Start at the Airspring furthest from the compressor. Trim the airline so that the cut is clean and as square as possible. Insert the end of the airline into the fitting pushing it in as far as possible. Route the airline from the airspring to the compressor keeping it away the exhaust pipe and sharp edges. If it is necessary to run the line over a sharp edge, use a supplied thermal sleeve over the airline to protect it. The sleeve is installed by sliding it over the airline to the area where the line needs protected. **The airline should not be bent or curved sharply, this can cause the line to buckle or kink.** Secure the airline in place using the Zipties provided in the kit. Once the first airspring line is ran to the compressor, trim off the excess and use it for the remaining air spring line to the compressor. With both lines ran from the air spring to the compressor, install the "T" fitting on the lines and run the remaining side of the "T" fitting to the compressor fitting.

TIP: Wetting the end of the airline before sliding it into the fitting makes it easier to install into the fitting.

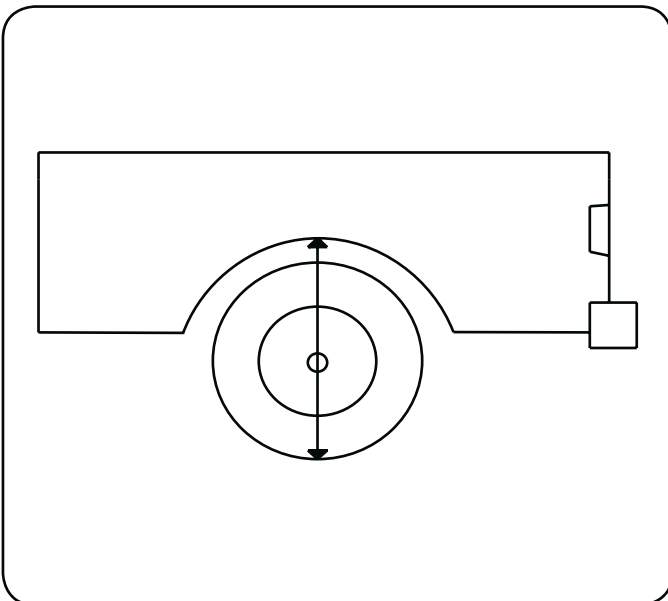

16. Once the system is installed you can verify the operation of the system by putting a load on the truck. With a load on the truck and the button illuminated blue, your fender to ground measurement that you took on the first step should be the same. If it is higher or lower you can adjust the height by loosening the 4 screws that attach the sensor to the bracket and twist in its mount. If ride height can not be achieved by adjusting in the bracket the linkage will need to be lengthened or shortened to achieve the height you need.

Manual Operation:

The LevelTow Compressor System also has a manual control function. This function allows you to manually inflated or deflate the system. To use the manual function you must first turn the system off by pushing the main power button. Once the system is turned off you can push the rocker switch up to inflate or down to deflate. To put the system back in level mode push the main power switch to turn it back on.

Note:

If the Activation Button is illuminated blue and the manual button is pushed the truck will relevel itself. The activation button has to be off for the manual control to be used and the truck remain at the height.

Troubleshooting:

If after installation you find the system not functioning correctly, you may have the sensor operating the wrong direction. You can verify this by turning the truck on and check that the activation button is illuminated blue. Unhook one end of the linkage and move the sensor arm by hand. If when you move the arm down (Keep in mind there is an 20 second delay) and the Air spring inflates, the sensor is operating in the wrong direction. You can fix this problem without remounting the sensor by swapping the blue and green wires in the harness at the sensor. To do this, with the truck turned off, simply unplug the harness from the sensor. Using a small screwdriver pop the purple retainer out of the plug by prying up on each end of it. After removing the retainer if you look into the end of the plug you will see a tang holding each wire terminal. Simply pry it down just enough to release the terminals of the blue and green wires. Swap the blue and green wire position and reinstall the wires into the plug paying attention to the direction of the small tab on the wire terminal. This tab will point to the center of the plug. Push the wire terminals into the plug making sure they catch on the tang and reinstall the purple retainer. After plugging the sensor back in you can confirm correct operation by turning the truck back on moving the sensor arm up, the Air spring should inflate. If the system is functioning correctly, shut the truck off and reattach the linkage.

