

ARF5005 Front airspring, bracket, shock kit for 97- 03 Ford F-150

- 2 F6781 front airsprings
- 2 A029c upper airspring mounts
- 1 A327D Lower airspring mount
- 1 A327P lower airspring mount
- 2 MON33033 shocks and 2 sleeves for upper
- 2 S0002 1/2" shock studs
- 2 A147 upper shock mounting brace
- 2 A035 upper shock mounts
- 2 DAY2060 short bumpstops (these replace the factory bumpstops)

Fasteners =

- | | | |
|----|-----------------------|---|
| 2 | 7/16 x 8 studs | upper airspring bracket mounting |
| 4 | 7/16 sae flat washers | |
| 4 | 7/16 uss nylocs | |
| 2 | 7/16 x 1 1/4 bolts | for upper shock mounts |
| 2 | 1/2 x 2 1/2 bolts | upper shock bolts |
| 2 | 1/2 uss nylocs | |
| 8 | 3/8 uss nyloc nuts | airspring to upper mount / lower plate to a-arm |
| 2 | 3/8 x 3/4 uss bolts | airspring lower mounting |
| 4 | 3/8 x 1 1/4 uss bolts | lower plate to a-arm |
| 2 | 3/8 lock washers | airspring lower mounting |
| 14 | 3/8 flat washers | airspring to bracket / lower bracket to a-arm |
| 2 | 5/16 x 1 bolts | relocate brake line forward on A-arm |
| 2 | 5/16 sae flat washers | |
| 2 | 5/16 uss nylocs | |

INSTRUCTIONS

ARF5005
97 to present Ford F150

Front airspring system installation

1. Raise vehicle to a comfortable working height and support by the frame.
2. Remove coilsprings. Refer to factory shop manual for proper procedure.



3. Fit the lower airspring plate into the lower control arm. This plate will be positioned by the oem swaybar hole. The remaining attachment holes will need to be drilled into the control arm using the plate as a template.

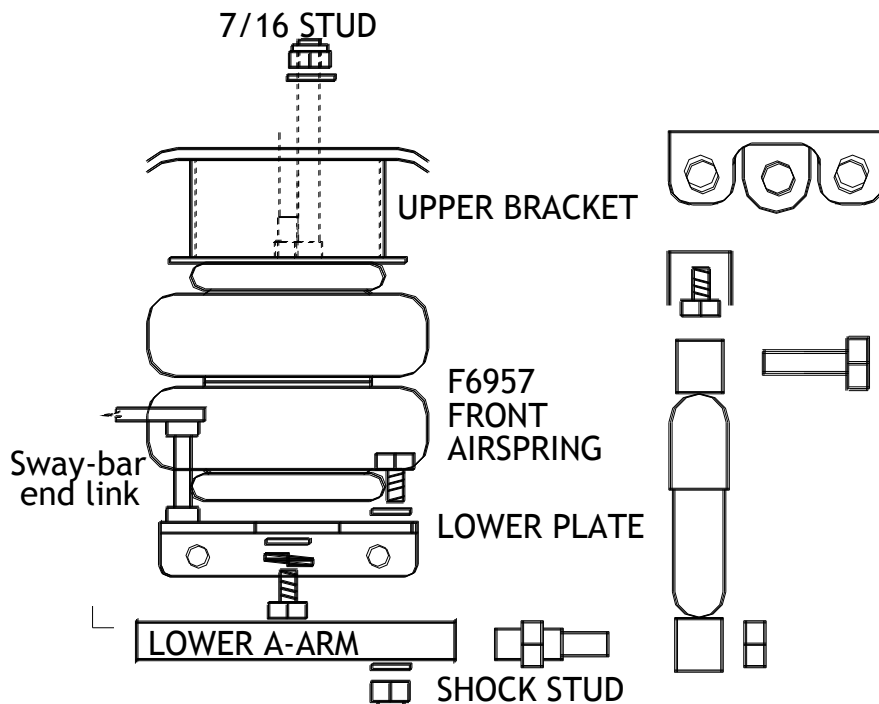

4. When the attachment holes are finished, assemble the airsprings onto their brackets and install the airline fitting [see sketch to the left]. Be sure to use Teflon tape or paste to prevent air leaks.
5. Install the airspring/bracket assembly into the oem coilspring location. A supplied threaded stud, stepped washer, and nyloc nut will attach the upper cup and supplied bolts will fasten the lower control arm plate.

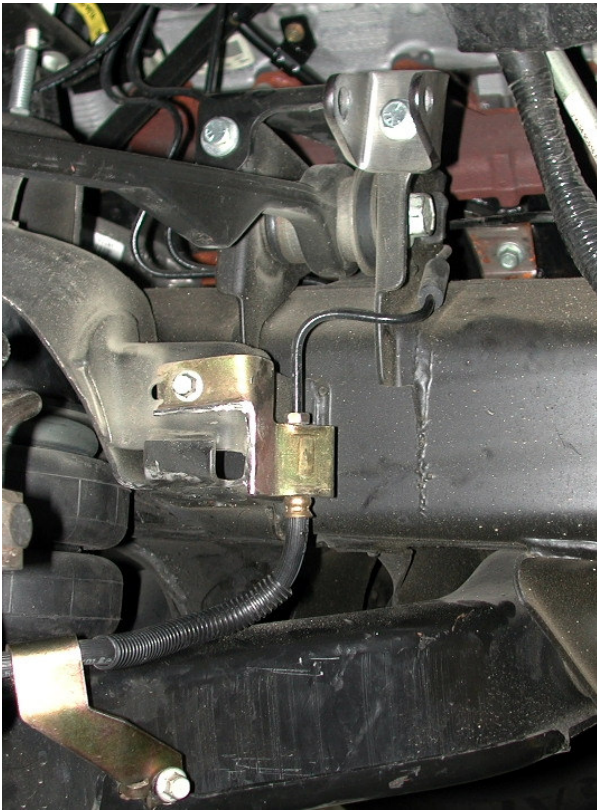

6. Install the upper shock mount and brace assembly onto the rear upper control frame bracket. Do not tighten the shock bracket bolt until the shocks are actually installed to set the final angle of that bracket.

Note: The brake line bracket may need to be trimmed for shock clearance.



7. The bottom of the shock is attached to the rear of the lower control arm slightly inboard of the bracket tab shown to the left. A 5/8" hole is needed to install the provided shock stud. Check your tire clearance closely before selecting the final location for this stud. After the stud and shock are installed, the upper bracket may be final tightened.

VEHICLE MUST BE ALIGNED BEFORE DRIVING

After finishing the installation, please double check the clearance around each airspring through the entire wheel travel and the steering travel. Be sure to check for proper tire clearance and for proper ground clearance throughout the entire suspension movement. Take the vehicle for a short test drive and check it again.

REMEMBER:

THE AIRSPRING BELLOWS MUST NOT TOUCH ANY THING AT ANYTIME!

A MINIMUM OF 2" OF GROUND CLEARANCE MUST BE MAINTAINED WHEN THE AIRSPRING IS COMPLETELY DEFLATED.