



**Part # 13046110**  
**Mopar LX Platform Rear CoilOver – HQ Series**  
**05-08 Magnum / 05-Up 300C / 06-Up Charger / 08-Up Challenger**

**Shock:**

2	24169999	6.3" stroke shock HQ Series
2	90002357	Aluminum Reducer Puck
2	90002026	3.7" Eyelet
2	90001995	Bearing Snap Ring
2	90001994	.625" ID Bearing
2	90002441	Spring Cap Spacer

**Components:**

2	59120225	12" 225lb Coilspring
2	90002230	Steel washer for rubber mount
2	70010949	Upper rubber isolator
2	90001973	Lower rubber isolator (T-shaped)
2	90002369	Rubber Bushing Housing
2	70011577	Aluminum upper Shock plate
2	90002222	Spring Retainer kit
2	90002070	Drop Spring Cap
2	90009982	Upper Shock Mount
4	70010828	Delrin Spring Washers
4	90002043	Upper Bearing Spacers (Narrow)
4	90002443	Lower Bearing Spacers (Wide)

**Hardware:**

6	99502001	½"-13 Nylok Nut	Shock Mounting
2	99501004	½"-13 x 3" Bolt	Lower Shock Mount to Arm
4	99501003	½"-13 x 2 ½" Bolt	Upper Shock Mount

# Mopar LX Front CoilOver Assembly

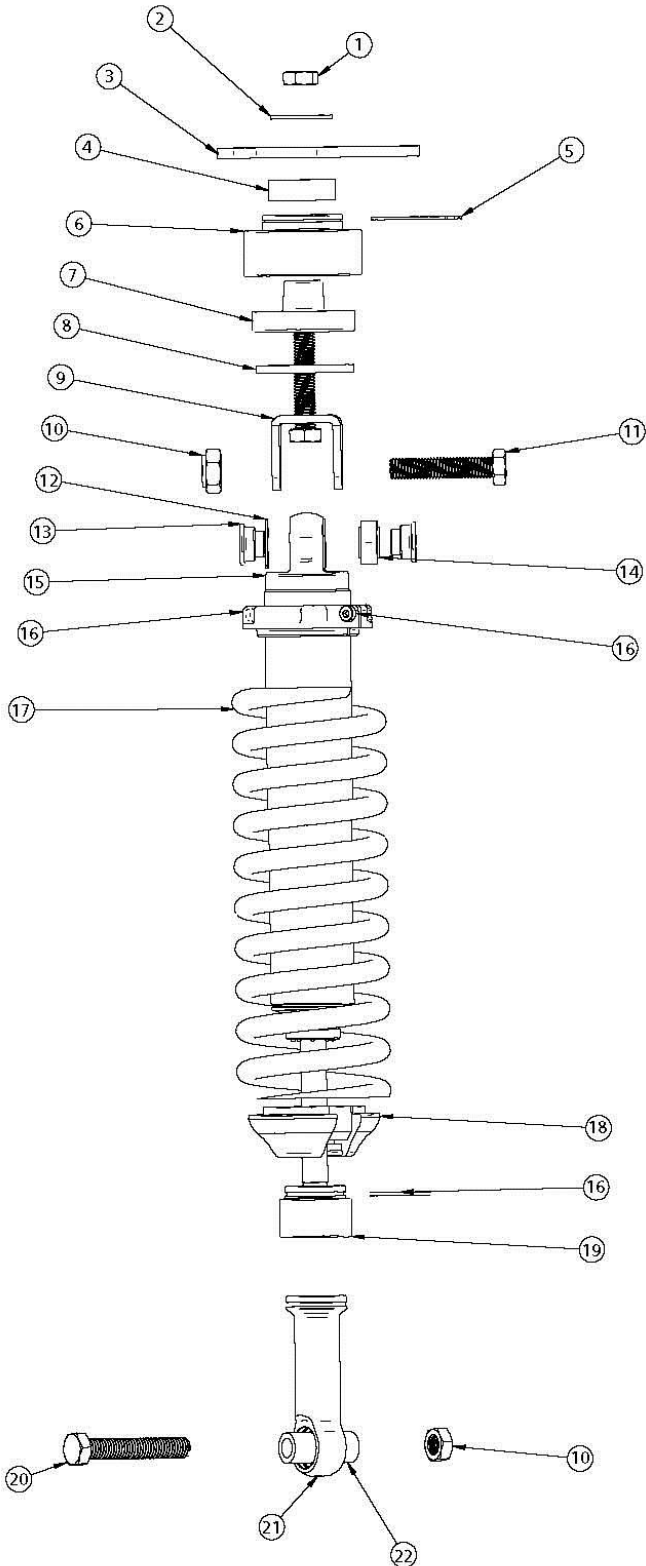

Item Number	Description	Qty.
1	1/2"-13 Nylock Nut 99502001	2
2	11/16" Flatwasher 99683001	2
3	Upper Mounting Plate 70011557	2
4	Upper Rubber Isolator 70010949	2
5	Retaining Ring 720002222	2
6	Aluminum Upper Mount 90002369	2
7	Lower Rubber Isolator 90001973	2
8	Isolator Washer 90002230	2
9	Upper Shock Mount 90009982	2
10	1/2"-13 Nylok Jam Nut 99502001	4
11	1/2"-13 x 2 1/2" hex Bolt 99501003	4
12	Bearing Snap Ring 90001995	8
13	Upper Bearing Spacer 90002043	4
14	.625" ID Bearing 90001994	4
15	6.3" Stroke HQ Shock 24169999	2
16	Coilspring Retainer kit 90002222	2
17	12" 225lb Coil Spring 59120225	2
18	Drop Coil Spring Cap 90002070	2
19	Spring Cap Spacer 90002441	2
20	1/2"-13 x 3" Hex Bolt 99501004	2
21	3.7" Eyelet 90002026	2
22	Lower Bearing Spacers 90002443	2

# COILOver

## Installation Instructions

1. Raise the vehicle to a safe and comfortable working height with the suspension hanging freely.
2. Remove the factory springs, shocks and upper mounts, refer to the service manual for proper disassembly procedures. **Retain the factory upper hardware for reassembly.**
3. Assemble the CoilOver using the drawing on the previous page as a reference.

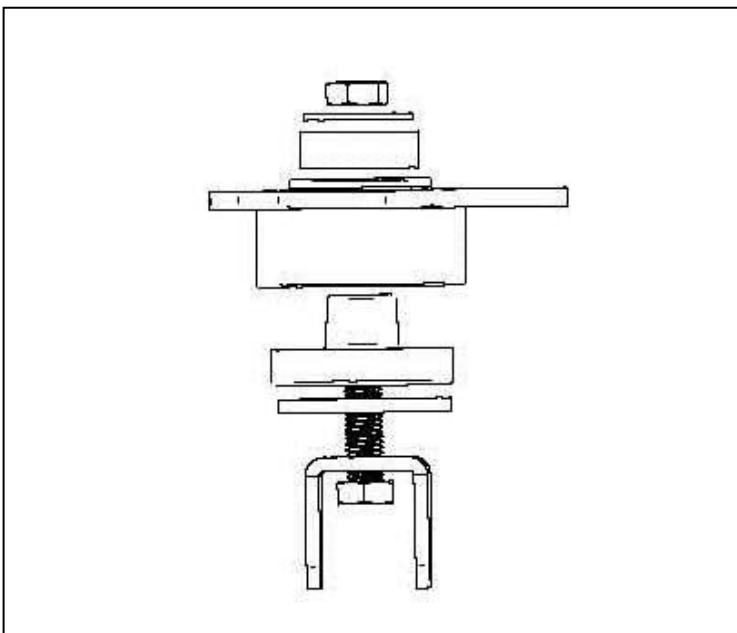

4. Assemble the upper shock mount using the illustration as a reference. **The upper shock bolt must run parallel with the lower shock bolt.**

**Note:** The upper shock bolt must run parallel with the upper shock bolt.

5. Assemble the spring onto the shock. The upper adjusting knob will have to be adjusted all the way in and then the knob removed to be able to install the upper coil spring mount. Slide the upper mount over the eyelet. Install the retaining snap ring, and then reinstall the adjuster knob.



6. Install the CoilOver assembly into the upper mount with a narrow spacer in each side of the bearing. Attach it to the upper mount using a 1/2" x 2 1/2" bolt.

7. Bolt the assembly to the body of the car using the factory hardware.

8. Attach sway bar to Coilover using the factory hardware.



9. Attach the eyelet to the lower control arm using a wide spacer in each side of the bearing. Attach the eyelet using a  $\frac{1}{2}$ " x 3" bolt and Nylok nut.

**Note:** Locate the adjuster knob facing the wheel of the car.

### Ride Height

We have designed most cars to have a ride height of about 2" lower than factory. To achieve the best ride quality & handling, the shock absorber needs to be at 40-60% overall travel when the car is at ride height. This will ensure that the shock will not bottom out or top out over even the largest bumps. Measuring the shock can be difficult, especially on some front suspensions. Measuring overall wheel travel is just as effective and can be much easier. Most cars will have 4-6" of overall wheel travel. One easy way to determine where you are at in wheel travel is to take a measurement from the fender lip (center of the wheel) to the ground. Then lift the car by the frame until the wheel is just touching the ground, re-measure. This will indicate how far you are from full extension of the shock. A minimum of 1.5" of extension travel (at the wheel) is needed to ensure that the shock does not top out. If you are more than 3" from full extension of the shock then you are in danger of bottoming out the shock absorber.

### Adjusting Spring Height

When assembling the CoilOver, screw the spring retainer tight up to the spring (0 preload). After entire weight of car is on the wheels, jounce the suspension and roll the car forward and backward to alleviate suspension bind.

- If the car is too high w/ 0 preload then a smaller rate spring is required. Although threading the spring retainer down would lower the car, this could allow the spring to fall out of its seat when lifting the car by the frame.
- If the car is too low w/ 0 preload, then preload can then be added by threading the spring retainer up to achieve ride height. On 2.6" - 4" stroke shocks, up to 1.5" of preload is acceptable. On 5-7" stroke shocks, up to 2.5" of preload is acceptable. If more preload is needed to achieve ride height a stiffer spring rate is required. Too much preload may lead to coil bind, causing ride quality to suffer.

## Shock adjustment 101- Single Adjustable

### Rebound Adjustment:

How to adjust your new shocks.

The rebound adjustment knob is located on the top of the shock absorber protruding from the eyelet.

You must first begin at the ZERO setting, then set the shock to a soft setting of 20.



-Begin with the shocks adjusted to the ZERO rebound position (full stiff). Do this by rotating the rebound adjuster knob clockwise until it stops.



-Now turn the rebound adjuster knob counter clock wise 20 clicks. This sets the shock at 20. (settings 21-24 are typically too soft for street use).

### Take the vehicle for a test drive.



-if you are satisfied with the ride quality, do not do anything, you are set!



-if the ride quality is too soft increase the damping effect by rotating the rebound knob clock wise 3 clicks.

### Take the vehicle for another test drive.



-if the vehicle is too soft increase the damping effect by rotating the rebound knob clock wise 3 additional clicks.



-If the vehicle is too stiff rotate the rebound adjustment knob counter clock wise 2 clicks and you are set!

Take the vehicle for another test drive and repeat the above steps until the ride quality is satisfactory.

### Note:

One end of the vehicle will likely reach the desired setting before the other end. If this happens stop adjusting the satisfied end and keep adjusting the unsatisfied end until the overall ride quality is satisfactory.