

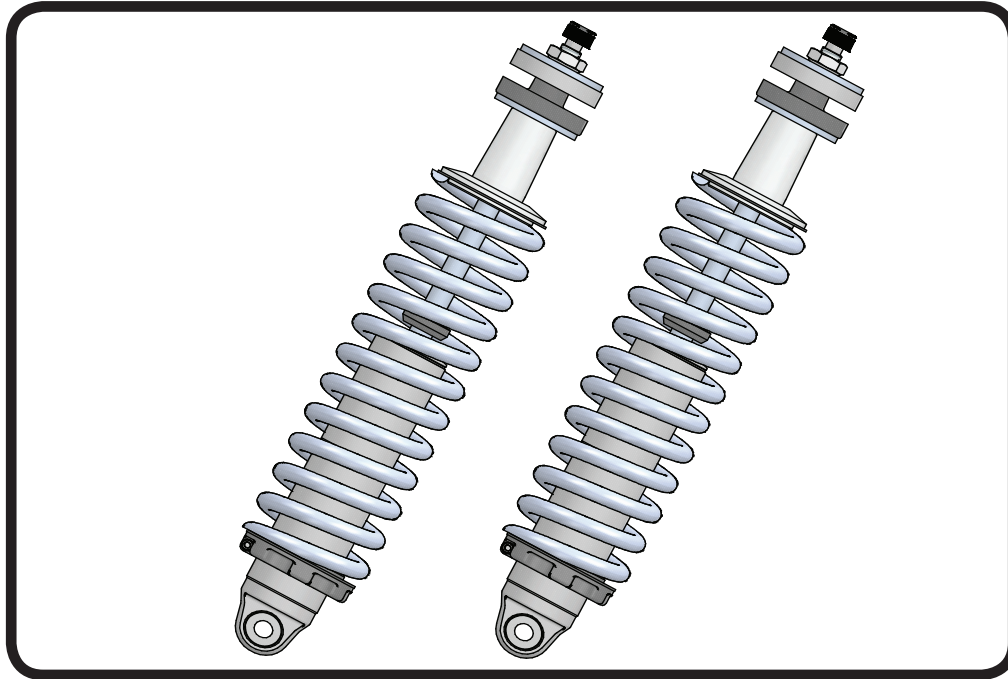

Part # 12156110 - 2005 up Mustang HQ Rear CoilOvers

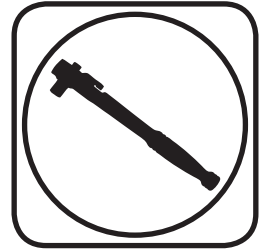

Recommended Tools



2005 up Mustang HQ Series Rear CoilOvers Installation Instructions

Table of contents

- Page 2..... Included components
- Page 3..... Getting Started and Disassembly
- Page 4..... CoilOver Assembly
- Page 5..... CoilOver Installation
- Page 6..... Final Assembly and CoilSpring Adjusting
- Page 7..... Shock Adjustment



Major ComponentsIn the box

Item #	Part #	Description	QTY
1	24159999	5.2" Stroke HQ Series Shock	2
2	59120225	12" 225lb CoilSpring	2
3	90009993	3.75" Stud Top	2
4	90001628	1/2" ID Bearing (Installed in Shock Body)	2
5	90001995	Bearing Snap Ring (Installed in Shock Body)	4
6	70010828	Delrin CoilSpring Washer	4
7	90002447	3.75" Stud Top Base	2
8	90002229	Rubber Isolator Backer Plate Upper & Lower	4
9	90001973	Lower Rubber Isolator (T shaped)	2
10	90001974	Upper Rubber Isolator	2
11	99562003	9/16-18" Nylok Nut	2
12	90002222(kit)	CoilSpring Plate Retaining Ring	2
13	90002222(kit)	Upper CoilSpring Retaining Plate	2
14	90002222(kit)	Lower Spring Adjuster Nut (90002222 kit)	2
15	90002222(kit)	Adjuster Nut Locking Screw (90002222 kit)	2
16	90000581	Inner Lower Shock Spacer	2
17	90000580	Outer Lower Shock Spacer	2
	99502001	1/2"-13 Nylok Nut (Lower Shock Bolt)	2
	99501024	1/2"-13 x 3 1/4" Hex Bolt (Lower Shock Bolt)	2

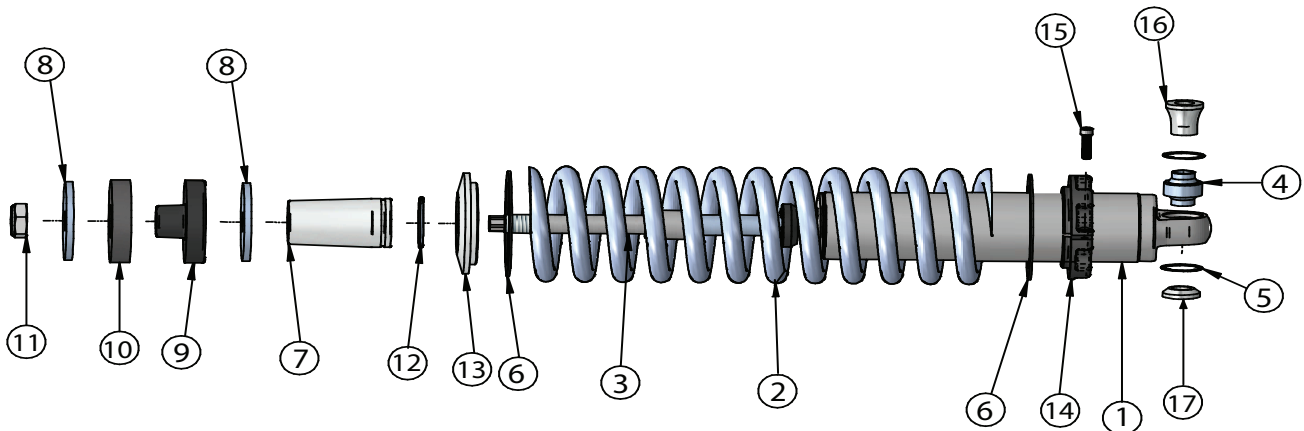



Getting Started and Disassembly

Congratulations on your purchase of the Ridetech Mustang CoilOver System. This system has been designed to give your Mustang excellent handling along with a lifetime of enjoyment. The CoilOver System provides flexibility that can not be achieved with Conventional CoilSprings. The CoilOver System will give you the flexibility of adjusting your ride height along with numerous spring options to dial in your ride quality to your personal preference.

This CoilOver System is Designed to replace the factory Shock and CoilSprings.

1. The rear OEM Shocks, Bumpstops and CoilSpring will need to be removed from the Rear of the car.
2. Raise the vehicle and support it by the frame allowing the suspension to hang freely. Be sure the rear differential will be able to swing down to get the rear springs out.
3. Place a jack under the center of the rear differential and raise it up to the point the jack is touching the rear differential. Be sure that the car is high enough that you will be able to lower the jack supporting the rear differential to remove the Coilsprings.
4. Pull the carpet on the sides of the trunk to expose the upper shock attaching nut and remove the nut.
5. Unbolt the lower shock from the shock mounting bracket.
6. Lower the jack slowly to remove the tension of the Coilspring. Pay attention to the brake line and ABS wire that you don't damage them when lowering the differential
7. With the springs loose, remove the from the car.
8. Remove the OEM bumpstop from the rear differential.
9. Remove the plastic cap from the differential in the factory coilspring location

To get Started refer to the page 4 on how to assemble the CoilOver



CoilOver Assembly

10.

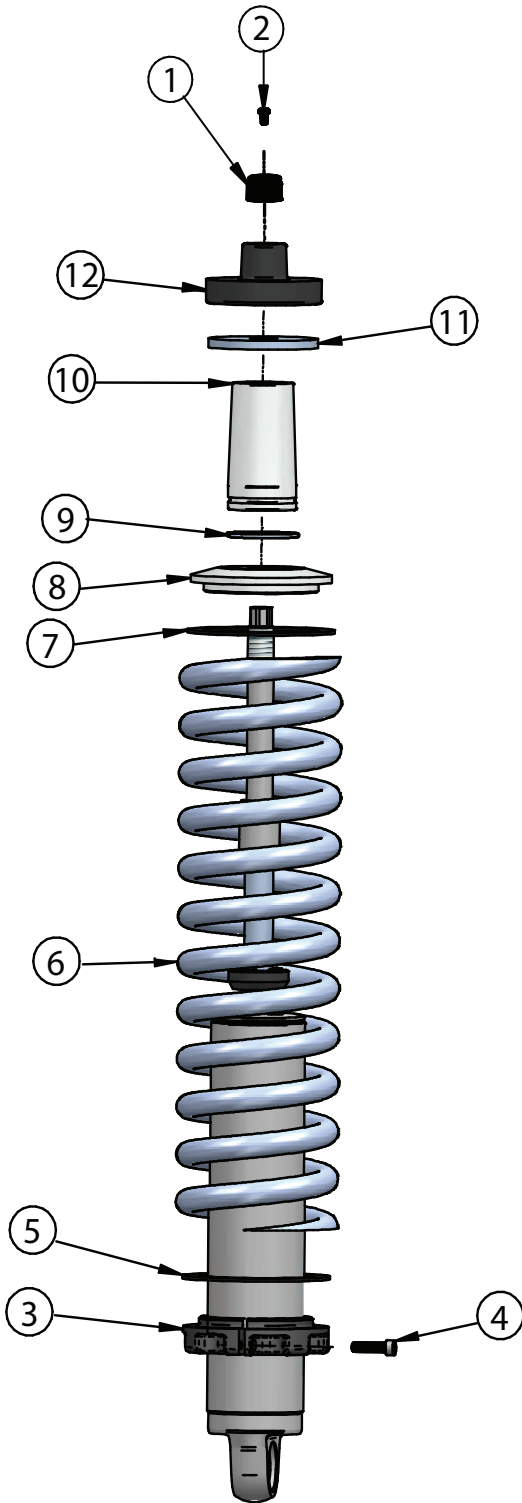

10. To Assemble the CoilOver you need to:
- a. Remove Screw (2) from center of Adjustment Knob (1) and remove Adjustment Knob.
 - b. Remove Nylok Nut, Delrin Upper Cap, Delrin Upper and Lower Balls, along with the base from the Coliover stud.
 - c. Thread Adjuster Nut (3) onto the CoilOver body. Once it is threaded on the shock body, lightly thread in the locking screw (4) into the Adjuster Nut.
 - d. Install a Delrin Spring Washer (5) onto the Adjuster Nut.
 - e. Slide the CoilSpring (6) onto the CoilOver.
 - f. Install another Delrin Spring Washer (7) on top of the CoilSpring.
 - g. Install the Upper CoilSpring Plate (8) onto the CoilSpring.
 - h. Install the CoilSpring Retaining Ring (9) onto the Stud Top Base (10). It fits into the groove in the base.
 - i. Slide the Stud Top Base onto the shock until it bottoms out on the stud. It may be necessary to thread the Adjuster Nut down the shock body (to lower the spring) if the base will not slide all the way down onto the stud.
 - k. Slide the Lower Isolator Backer Plate (11) on to the Stud Top.
 - l. Slide the Lower Rubber Isolator (12) onto the stud top.

Repeat on second CoilOver.



CoilOver Installation

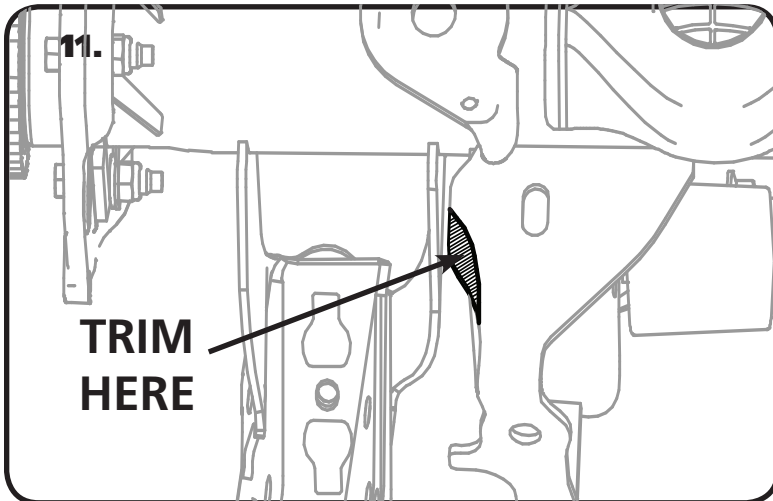

11. Before installing the CoilOvers it is necessary to do some trimming on the rear differential brackets for clearance. The corner of the panhard mount on the drivers side needs to be cleared like seen in Figure #11.

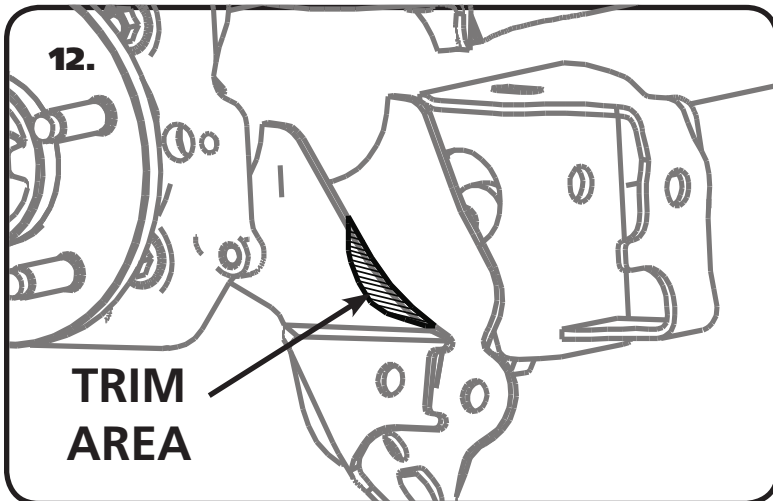

12. Next, the lower shock mount on both sides needs to be cleared for the shock to clear. Clearance the shock mount similar the Figure 12. Once the shocks are installed check the clearance through the entire shock travel.

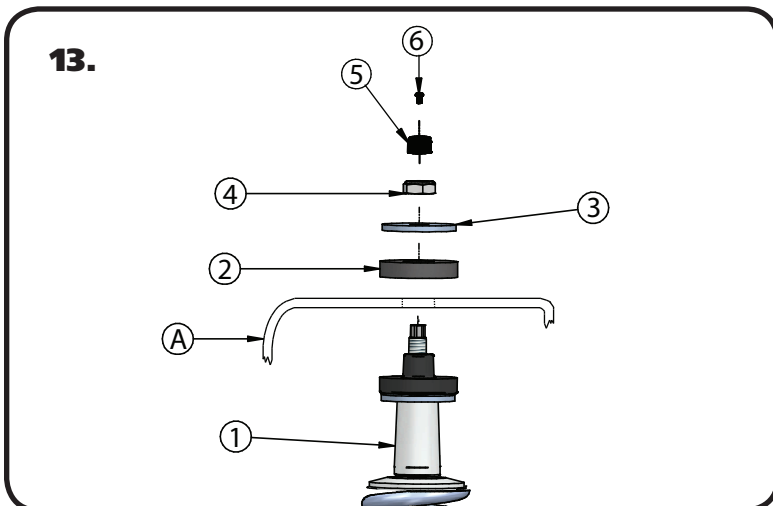

13. With the CoilOver(1) assembled, it is time to bolt them into the car. Insert the CoilOver Stud Top through the factory hole in the body. Install the Upper Rubber Isolator(2) onto the shock stud with the center hole slipping over the Lower Isolator stub sticking through the body. Next, Install the Rubber Isolator Backer Plate (3) onto the shock stud. Install the Nylok Nut(4) onto the shock stud and lightly tighten. Tighten the nut just enough to take any gap out of the bushing, its does not need to be so tight that the bushing is bulging. Reinstall the adjuster knob(5) using the screw (6) that was removed during step 10.



Final Assembly

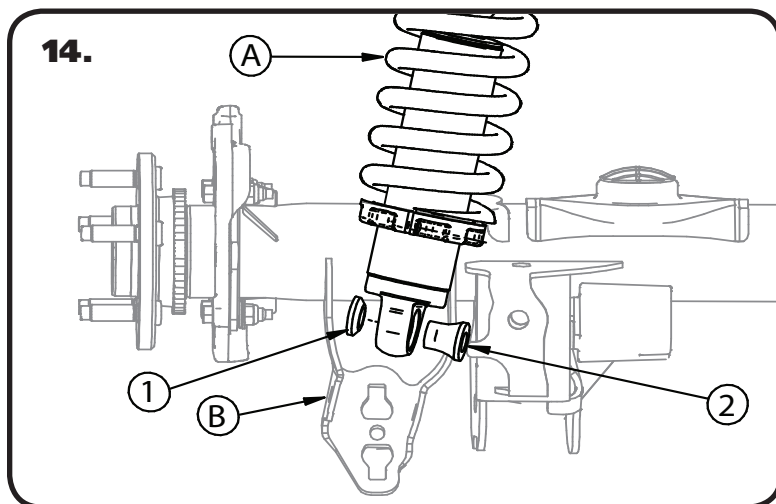

14. Install the CoilOver(A) in the OEM lower shock mount(B) using a Narrow Spacer(1) on the wheel side of the shock, and a Wide Spacer(2) on the inner side of the shock. Slide the shock into the stock mounting location. It may be necessary to use the jack and raise the differential to align the mounting holes. With the mounting holes aligned, install the 1/2"-13 x 3 1/4" bolt along with the 1/2"-13 Nylok nut.

Repeat the steps for the other side of the car.

CoilSpring Adjusting

Ride Height

We have designed most cars to have a ride height of about 1 1/2" lower than factory. To achieve the best ride quality & handling, the shock absorber needs to be at 40-60% overall travel when the car is at ride height. This will ensure that the shock will not bottom out or top out over even the largest bumps. Measuring the shock can be difficult, especially on some front suspensions. Measuring overall wheel travel is just as effective and can be much easier. Most cars will have 4-6" of overall wheel travel. One easy way to determine where you are at in wheel travel is to take a measurement from the fender lip (center of the wheel) to the ground. Then lift the car by the frame until the wheel is just touching the ground, re-measure. This will indicate how far you are from full extension of the shock. A minimum of 1.5" of extension travel (at the wheel) is needed to ensure that the shock does not top out. If you are more than 3" from full extension of the shock then you are in danger of bottoming out the shock absorber.

Adjusting Spring Height

When assembling the CoilOver, screw the spring retainer tight up to the spring (0 preload). After entire weight of car is on the wheels, jounce the suspension and roll the car forward and backward to alleviate suspension bind.

- If the car is too high w/ 0 preload then a smaller rate spring is required. Although threading the spring retainer down would lower the car, this could allow the spring to fall out of its seat when lifting the car by the frame.
- If the car is too low w/ 0 preload, then preload can then be added by threading the spring retainer up to achieve ride height. On 2.6" - 4" stroke shocks, up to 1.5" of preload is acceptable. On 5-7" stroke shocks, up to 2.5" of preload is acceptable. If more preload is needed to achieve ride height a stiffer spring rate is required. Too much preload may lead to coil bind, causing ride quality to suffer.



Shock Adjustment

Shock adjustment 101- Single Adjustable

Rebound Adjustment:

How to adjust your new shocks.

The rebound adjustment knob is located on the top of the shock absorber protruding from the eyelet.

You must first begin at the ZERO setting, then set the shock to a soft setting of 20.



-Begin with the shocks adjusted to the ZERO rebound position (full stiff). Do this by rotating the rebound adjuster knob clockwise until it stops.



-Now turn the rebound adjuster knob counter clock wise 20 clicks. This sets the shock at 20. (settings 21-24 are typically too soft for street use).

Take the vehicle for a test drive.



-if you are satisfied with the ride quality, do not do anything, you are set!

-if the ride quality is too soft increase the damping effect by rotating the rebound knob clock wise 3 clicks. **CONTINUE ON NEXT PAGE.**

Take the vehicle for another test drive.



-if the vehicle is too soft increase the damping effect by rotating the rebound knob clock wise 3 additional clicks.



-If the vehicle is too stiff rotate the rebound adjustment knob counter clock wise 2 clicks and you are set!

Take the vehicle for another test drive and repeat the above steps until the ride quality is satisfactory.

Note:

One end of the vehicle will likely reach the desired setting before the other end. If this happens stop adjusting the satisfied end and keep adjusting the unsatisfied end until the overall ride quality is satisfactory.