

LevelTOW

ADVANCED TOWING SOLUTIONS
by ridetech

81234008 2013-2019 RAM 3500 2WD

Congratulations - your new TowPro Helper Springs are quality products capable of improving the handling and comfort of your vehicle. As with all products, proper installation is the key to obtaining all of the benefits your kit is capable of delivering. Please take a few minutes to read through the instructions to identify the components and learn where and how they are used. It is a good idea to start by comparing the parts in your kit with the parts list below.

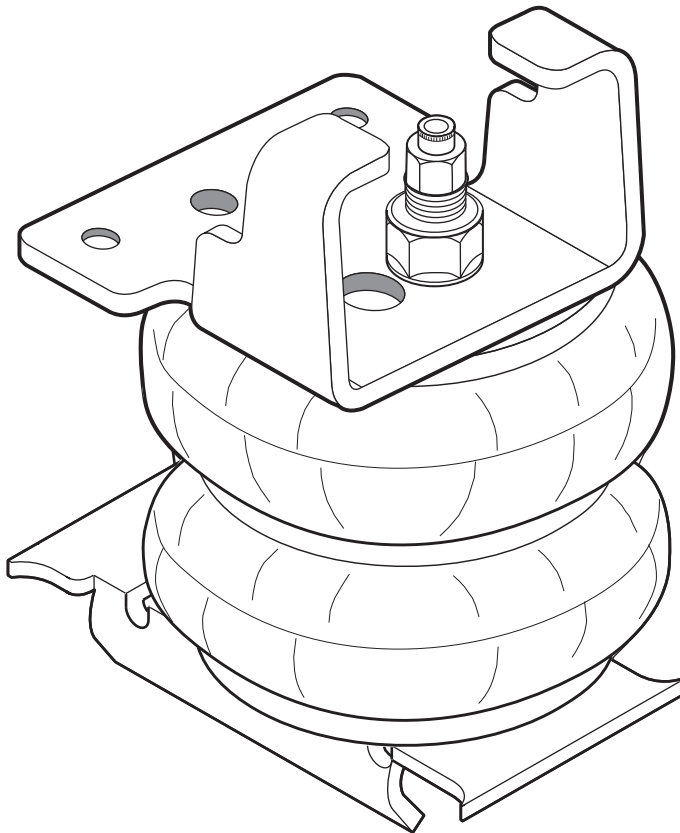

Components

Components	Part#	QTY
AIR SPRING	6401	2
UPPER BRACKET	5740	2
LOWER BRACKET	5370	2
AXLE BRACKET	5181	2
HEAT SHIELD	1004	1
18 ft. TUBING	0938	1
THERMAL SLEEVE	0899	2

Hardware

3/8"-16 BAIL CLAMP	3292	2
5/16" FLAT WASHER		4
3/8"-16 X 3/4" FLANGE LOCK		2
3/8"-16 FLANGE NUT		4
3/4"-16 HEX NUT		2
3/4" STAR WASHER		2
10MM X 50MM FLAT HD BOLT		4
NYLON TIE WRAP		6

WARNING!

Do not inflate this assembly when it is unrestricted. The assembly must be restricted by the suspension or other adequate structure. Do not inflate beyond 100 P.S.I. Improper use or over inflation may cause property damage or severe personal injury.

FIGURE "A"

NOTE: Both illustrations are of the left, or driver's side, of the vehicle. Reverse any orientations when assembling and installing the right, or passenger, side of the vehicle.

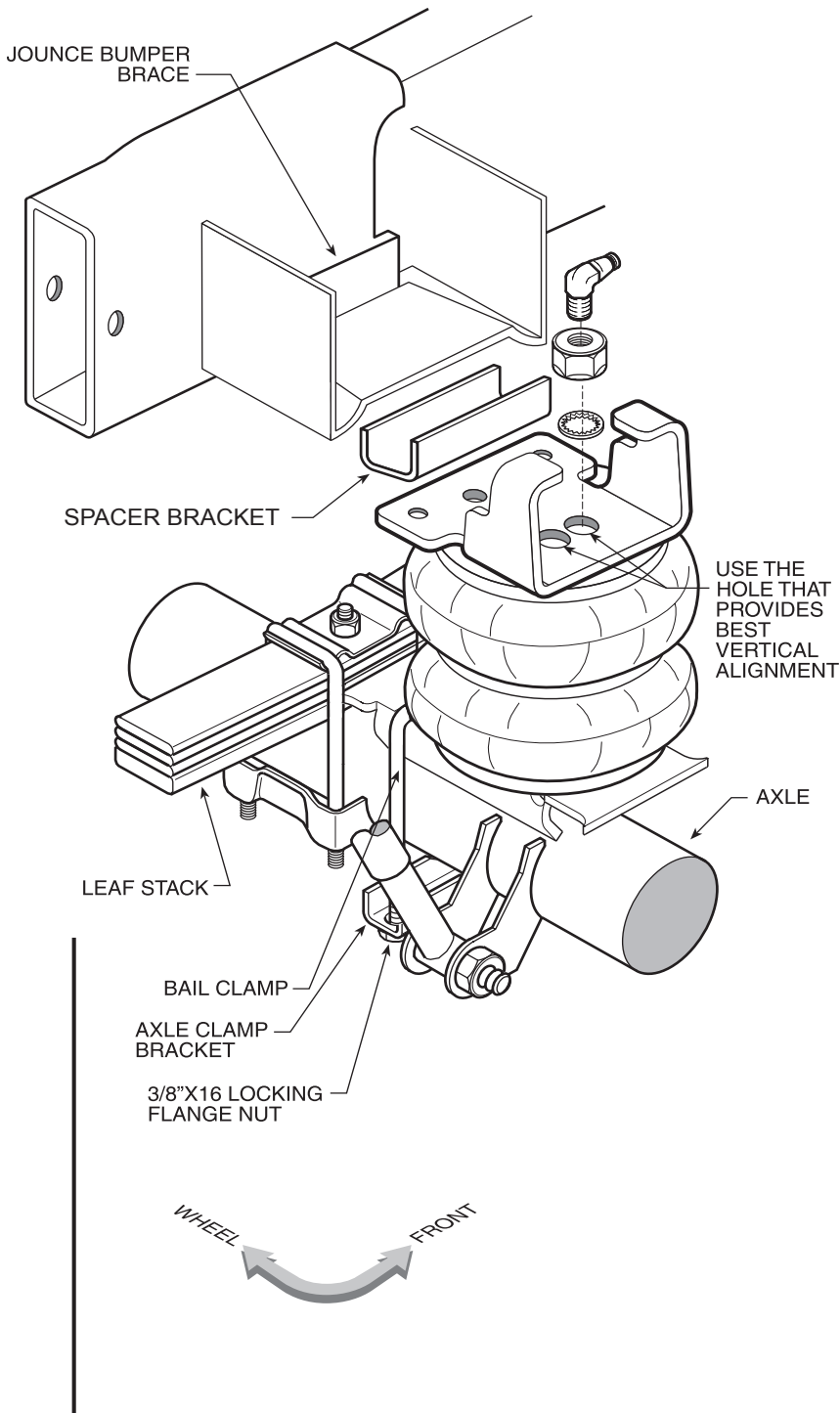

KIT ASSEMBLY

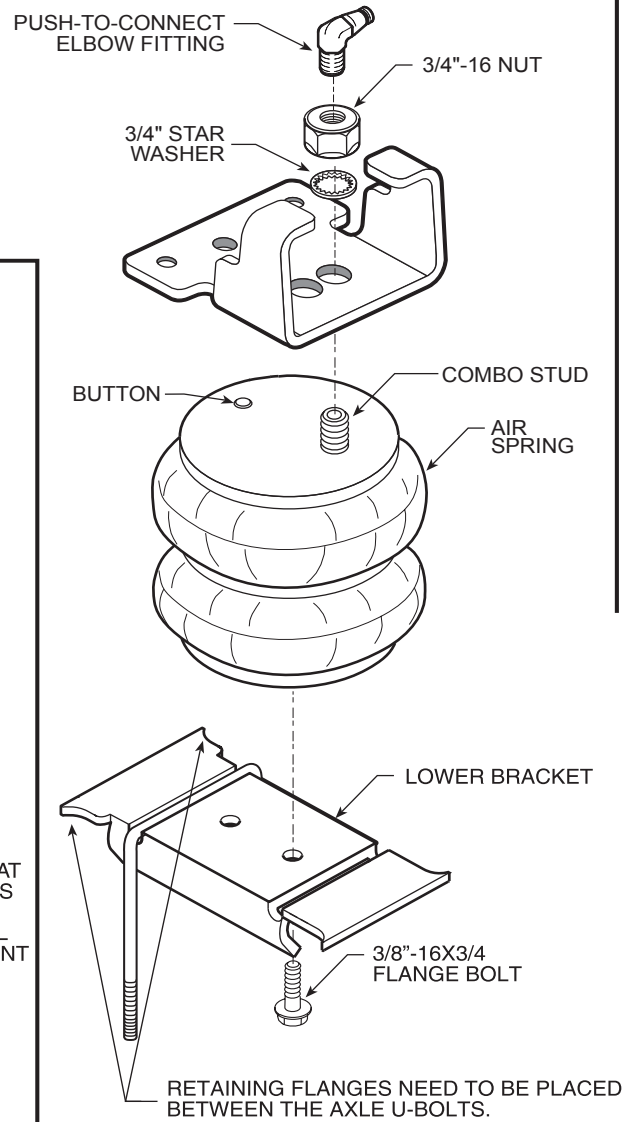

Lower Bracket Orientation

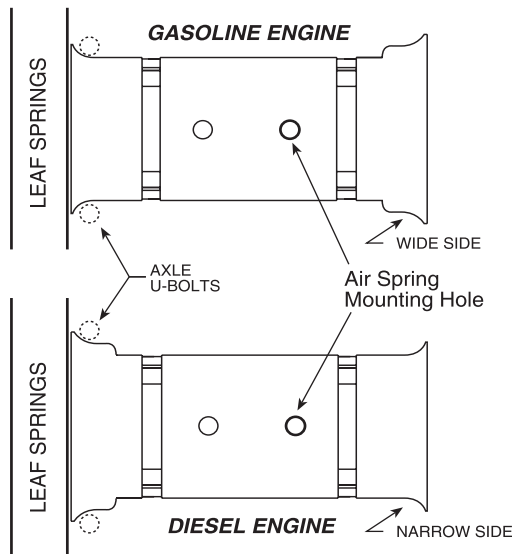

NOTE:

Please read through this manual completely before installing the air spring kit on your vehicle.

STEP 1 — PREPARE THE VEHICLE

With the vehicle on a solid, level surface chock the front wheels. Remove the negative battery cable. Your vehicle is equipped with rubber jounce bumpers. The jounce bumpers are bolted to the frame above the axle. Remove the jounce bumpers from the vehicle.

STEP 2 — PRE-ASSEMBLE THE KIT

Select a lower bracket from your kit and determine which side of the bracket fits most snugly between the axle U-bolts as shown in **Figure "A"**. **NOTE: The smaller side is for the gasoline engine axle and the larger side is for Diesel engine axle.** Select one air spring, bail clamp and lower bracket from your kit. Place the bail clamp in the correct position in the slot of the lower bracket for your vehicle. Install the air spring to the lower bracket using the hole for your vehicle with a 3/8"-16 x 3/4" flange head bolt that is mounted finger tight. **Please see the lower right section of Figure "A"**. The bolt will be tightened up in STEP 5.

STEP 3 — INSTALLING THE UPPER BRACKET TO THE VEHICLE

Select an upper bracket and spacer bracket from your kit. Install the upper bracket to the frame using two 10 mm x 30 mm flat head bolts, see **Figure "A"**.

STEP 4 — INSTALLING THE ASSEMBLY TO THE VEHICLE

Position the lower bracket and air spring assembly from STEP 2 on the axle as shown in **Figure "A"**. Put the large threaded stud through the large hole on the upper bracket and the locating pin of the air spring in the small hole on the upper bracket as shown in **Figure "A"**. **Make sure the alignment pin is in the locating hole before fastening air spring to the upper bracket.** Fasten the air spring to the upper bracket using 3/4"-16 hex head nut and 3/4" star washer. Fasten the lower bracket to the axle housing using the bail clamp and the axle clamp bracket and two 3/8"-16 locking flange nuts securely. Once the lower bracket orientation has been set, tighten the 3/8"-16 x 3/4" flange bolt that was installed in STEP 2. Next, install the male air fitting into the air inlet in the combo stud of the air spring. Tighten the air fitting securely to engage the orange thread sealant.

STEP 5 — INSTALLATION OF THE PASSENGER'S SIDE ASSEMBLY

Before following STEPS 1-4 with reverse orientations for assembly and installation of the passenger's assembly, a heat shield will need to be mounted between the upper bracket assembly and the top plate of the air spring, **see Figure "B"**. Position the heat shield directly between the closest heat source and the air spring. Ensure that the heat shield will not interfere with normal operation of the air spring or the vehicle's suspension. Do not position the heat shield directly above the axle, as it may contact the axle on full suspension travel.

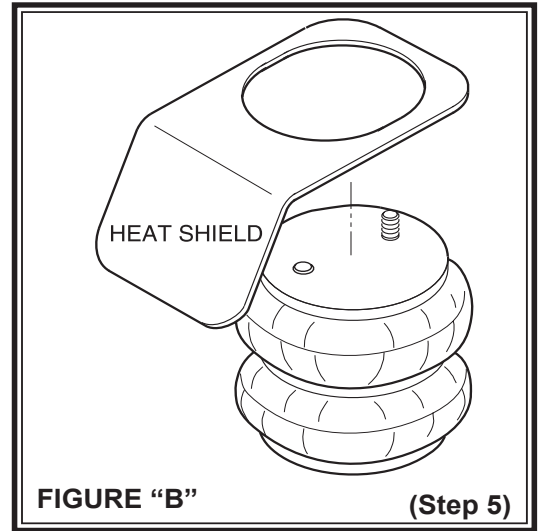

Important:

In order for the air spring to function properly, there must be a minimum of 1/2" of clearance around the air spring.



LevelTOW

ADVANCED TOWING SOLUTIONS
by ridetech

LevelTow Compressor System

Congratulations - your new LevelTow Compressor System is a quality product, that when used in conjunction with the LevelTow helper Air Springs, is capable of improving the handling and comfort of your vehicle. As with all products, proper installation is the key to obtaining all of the benefits your kit is capable of delivering. Please take a few minutes to read through the instructions to identify the components and learn where and how they are used. It is a good idea to start by comparing the parts in your kit with the parts list below.

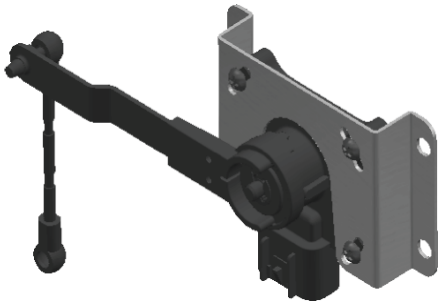

Components:

	Part #	QTY
Compressor Unit	31920022	1
Smart Sensor Height Sensor	31980006	1
Compressor Mounting Bracket	90002637	1
Smart Sensor Mounting Bracket	70014456	1
Sensor Linkage	31980011	1
Linkage Axle Bracket	70011429	1
Control Panel Bracket	70011439	1
Airline Fitting (mounted in compressor)	31957016	1
Main Activation Switch	35970000	1
Manual Control Switch	70011413	1
Main Wire Harness	31900051	1
Axle Bracket Clamp	99000005	1
1/4" TEE Fitting	31954400	1
1/4" Fitting for airsprings Straight / 90 Degree	31954000 / 31954201	2
20 amp fuse	90001922	1
Fuse Holder	90001924	1
10-12 Butt Connector for Fuse Holder	90001913	1
Ring Terminal for Main Power Hookup	90001916	1

Hardware:

#10 x 5/8" Phillips pan head - sensor to bracket	99104002	4
1/4"-14 x 1" Self Drilling Screw- Sensor to Frame	99254001	5
3/8-16 x 1" Thread Forming - Compressor Bracket to Frame	99373007	4
10-24 x 1 1/4" Maching Screw - Compressor to Bracket	99101007	4
10-24 Nylok Nut - Compressor to Bracket	99102002	4
#10 Flat Washer - Compressor to Bracket	99103001	8

The LevelTow Compressor System is an automatic leveling system, once it is turned on (button illuminated blue) it will operate without any assistance.

The Smart sensor supplied with the compressor system will tell the system to inflate or deflate to keep the vehicle level. It has a dwell range built in so that when the truck is going down the road hitting small defects the system will be idle. It isn't until the sensor gets out of this dwell range for 18 seconds that the system will react.

The activation switch has to be illuminated blue for the system to work.

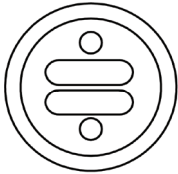

Activation Button

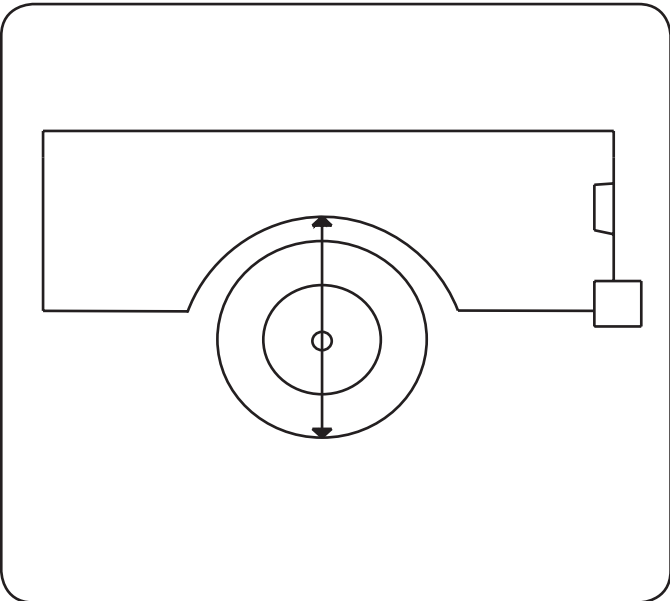

1. Before you install the compressor system, you will need to have the helper Airsprings installed. This will ensure that the LevelTow linkage does not get in the way of the Airsprings.

The first step to doing the install, with the vehicle at ride height, measure the lip of the fender to the ground at the center of the wheel and write it down.

Measurement _____

This measurement will be used as a reference once you have the compressor system installed.

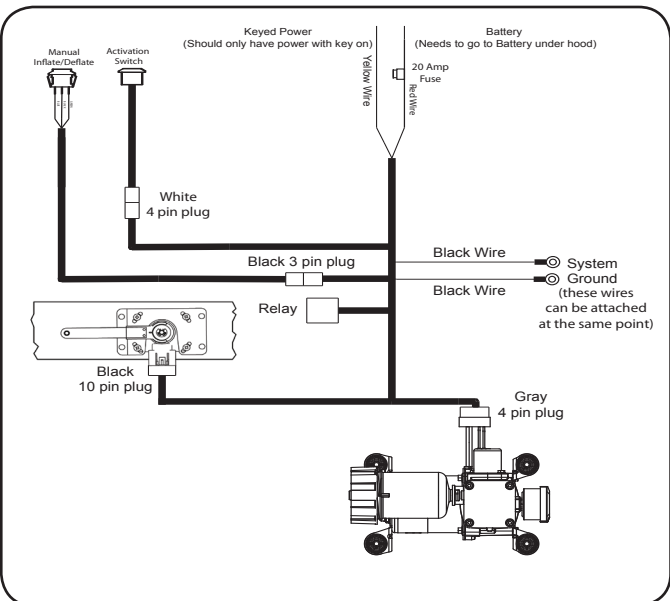

2. Unpack the wiring for the LevelTow system and lay it out. This will give you an idea to where you can mount the components without having to modify the wiring harness.

NOTE:
There is a wiring diagram on Page 7 to assist you in component location.

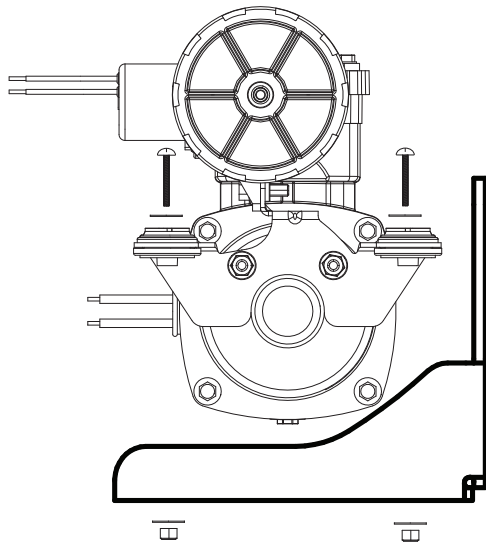

3. Bolt the compressor to the bracket. Position the compressor on the Bracket in the orientation shown. Line up the holes in the (4) Mounting Bushings with the (4) holes in the Bracket. Install a #10 Flat Washer on each of the (4) #10-24 x 1 1/4" Pan Head Screws. Insert a Screw/Washer in each of the 4 holes. Install a #10 Flat Washer on the threads sticking through the bottom of the bracket followed by a #10-24 Nylok Nut. Tighten the hardware.

NOTE:

The diagram shows the position the compressor goes onto the plate.

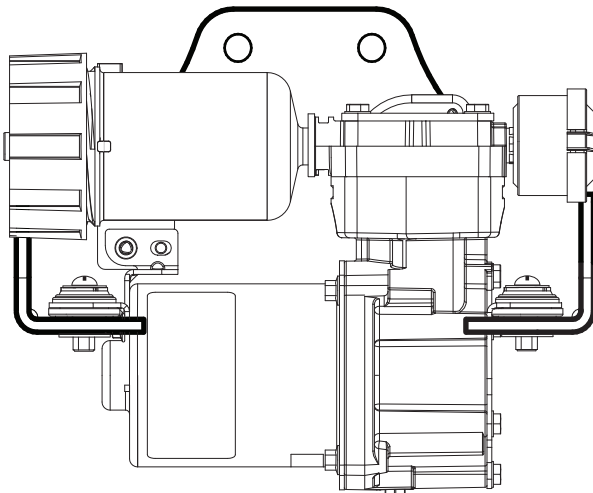

4. The compressor needs to be mounted on the frame rail with the dryer up. Attach the compressor bracket to the frame with (4) 3/8"-16 x 1" Thread Forming Bolts supplied in the kit. Drill a 5/16" Hole for the bolts.

NOTE:

Before drilling any hole be sure to check and see if there are any brake lines, fuel lines, or wires on the other side of the surface you are drilling.

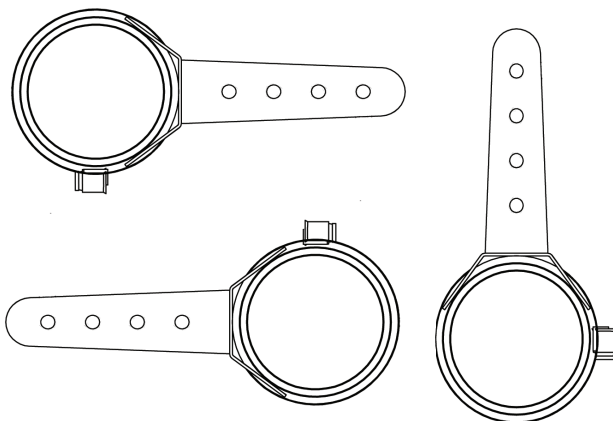

5. The Axle bracket can be mounted in any location on the axle tube to get the sensor linkage to line up. The Axle mount should be mounted on the axle so that the linkage will line up from the axle mount to the sensor. Keep this in mind when establishing the sensor location.

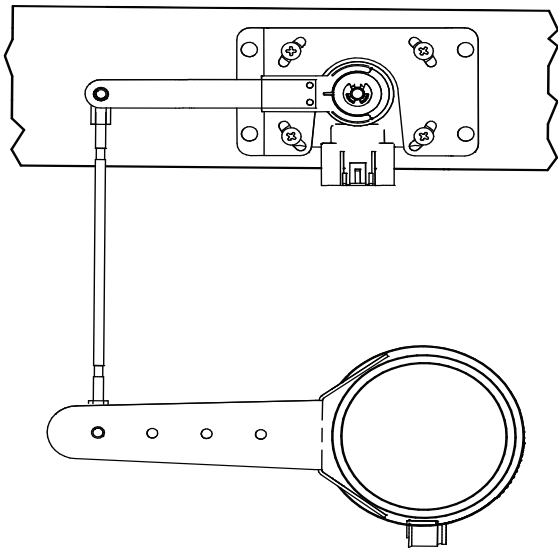

6. The next step will be to mount the sensor. The Smart Sensor needs to be centered in its travel at the trucks ride height to operate properly. This can be done by cutting the linkage rod to length. It can be fine tuned by loosening the 4 sensor mounting screws and twisting it in the mount and retightening the 4 screws. When the mounting and linkage is done it should look like the diagram seen here.

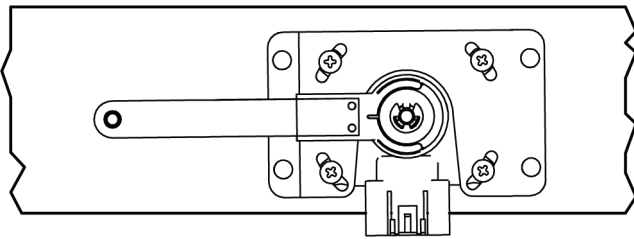

7. The sensor needs to be mounted on the frame rail with the wires pointing down. The arm will need to swing up opposite the direction of the wires as the suspension is being compressed. Attach the sensor bracket to the frame with (4) self drilling screws supplied with the kit.

NOTE:

The sensor can be mounted on the inside or outside of the frame. Make sure the linkage and arm can go through its entire travel without hitting any obstructions

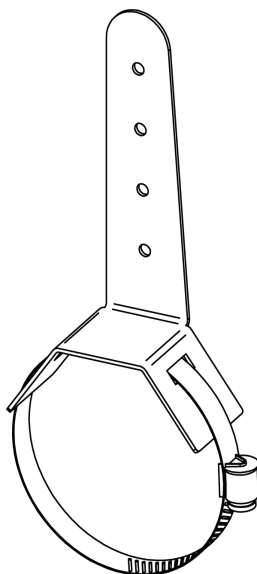

8. This diagram shows how the clamp sticks through the axle bracket. Loosen the clamp until it will open up and then slide it through the bracket. The whole assembly can then be put on the axle tube. Reinsert the end of the clamp back into the adjuster and tighten the clamp until the bracket is tight on the axle tube.

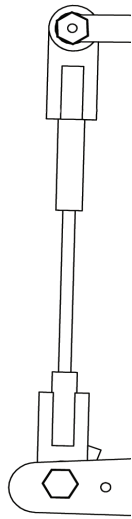

9. With the sensor and the axle bracket mounted, it is time to connect the 2 with the supplied linkage. The linkage is a universal length and will have to be cut to achieve the necessary length for your application. To do this it will be necessary to have the truck sitting at its factory ride height. With the truck at ride height center the sensor in its travel. The rod can slide into each rubber rod end up to 1”.

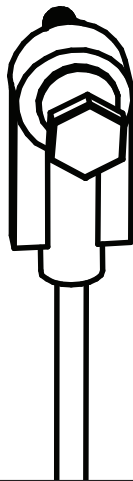

10. The linkage rod has barbs on the outside of it to keep it in the end link. After you push the ends in, they are difficult to pull back out. Push the linkage into the ends a little at a time until you get the desired length of the linkage assembly. If for some reason you must pull the rod out of the end, it is best done by twisting the end while pulling on it.

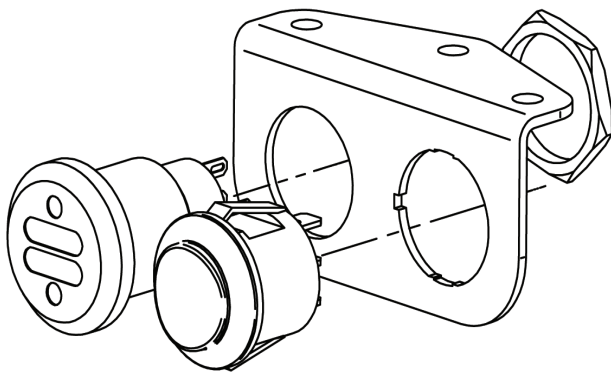

11. Mount the control panel in a convenient location. Install the Power Button and Manual Control Rocker into the panel. The Power Button gets installed into the round hole. The nut that is on the button is used to attach the button in the panel. The Rocker Switch goes into the hole with the notch in it. Align the tab on the switch with the slot and push the switch into the hole until it snaps in place. The rocker will only go into the hole one way. You can also custom mount the buttons if desired. They both use a 3/4” hole. The hole for the manual switch will have to have a slot for the tab

TOP

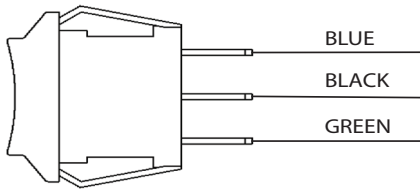

12. Hook the wires up to the manual control switch as shown in the diagram.

Green Wire-Manual Inflate
Black Wire -Switch Supply
Blue Wire - Manual Deflate

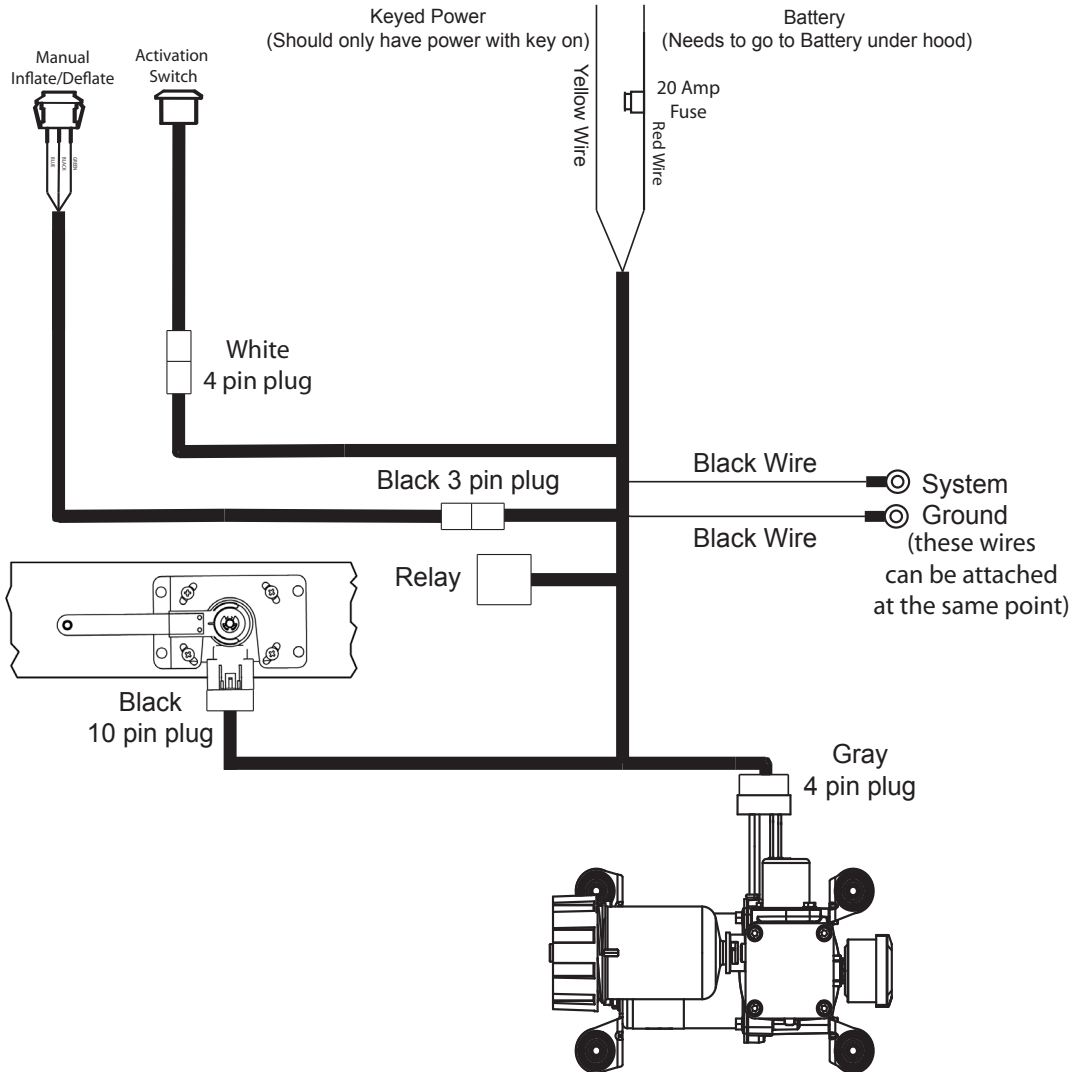

Red Wire - This wire needs to go straight to the **Battery** with the fuse holder installed within 18" of the Battery

Yellow Wire - This wire needs to go to a switched 12 volt power source. This wire should only have power when the key is on.

Black Wires - These wires go to a chassis ground. They can go to one of the screws attaching the compressor to the frame.

Relay - Will need to be attached to the frame with a self drilling screw supplied in the kit..

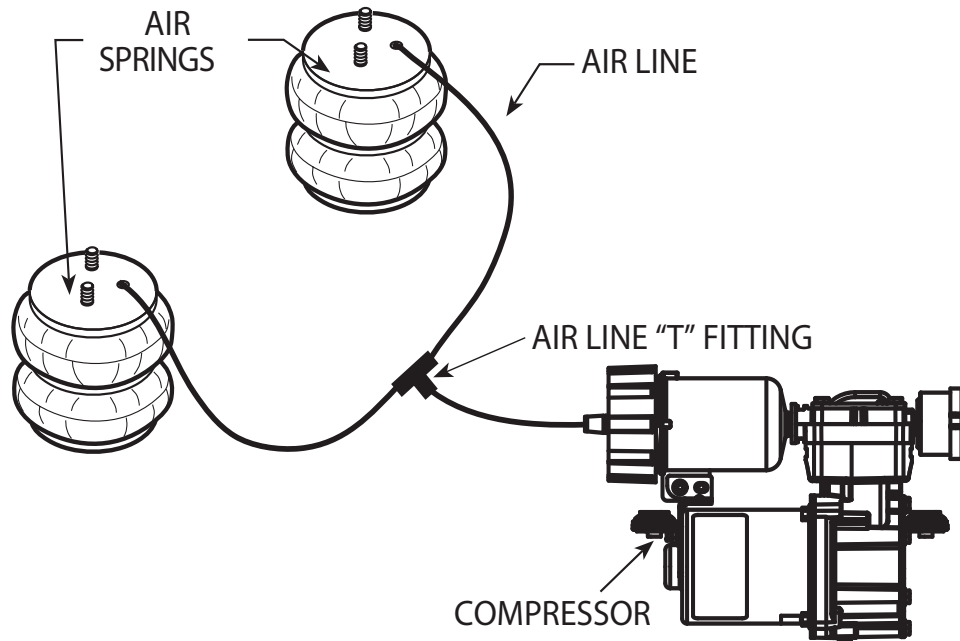

13. **Uncoil the airline being careful not to kink or flatten the line.** Start at the Airspring furthest from the compressor. Trim the airline so that the cut is clean and as square as possible. Insert the end of the airline into the fitting pushing it in as far as possible. Route the airline from the airspring to the compressor keeping it away the exhaust pipe and sharp edges. If it is necessary to run the line over a sharp edge, use a supplied thermal sleeve over the airline to protect it. The sleeve is installed by sliding it over the airline to the area where the line needs protected. **The airline should not be bent or curved sharply, this can cause the line to buckle or kink.** Secure the airline in place using the Zipties provided in the kit. Once the first airspring line is ran to the compressor, trim off the excess and use it for the remaining air spring line to the compressor. With both lines ran from the air spring to the compressor, install the "T" fitting on the lines and run the remaining side of the "T" fitting to the compressor fitting.

TIP: Wetting the end of the airline before sliding it into the fitting makes it easier to install into the fitting.

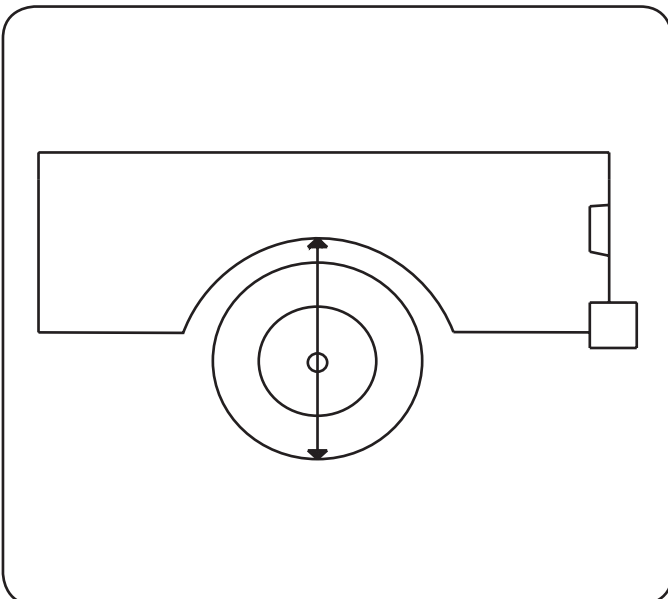

14. Once the system is installed you can verify the operation of the system by putting a load on the truck. With a load on the truck and the button illuminated blue, your fender to ground measurement that you took on the first step should be the same. If it is higher or lower you can adjust the height by loosening the 4 screws that attach the sensor to the bracket and twist in its mount. If ride height can not be achieved by adjusting in the bracket the linkage will need to be lengthened or shortened to achieve the height you need.

Manual Operation:

The LevelTow Compressor System also has a manual control function. This function allows you to manually inflated or deflate the system. To use the manual function you must first turn the system off by pushing the main power button. Once the system is turned off you can push the rocker switch up to inflate or down to deflate. To put the system back in level mode push the main power switch to turn it back on.

Note:

If the Activation Button is illuminated blue and the manual button is pushed the truck will relevel itself. The activation button has to be off for the manual control to be used and the truck remain at the height.

Troubleshooting:

If after installation you find the system not functioning correctly, you may have the sensor operating the wrong direction. You can verify this by turning the truck on and check that the activation button is illuminated blue. Unhook one end of the linkage and move the sensor arm by hand. If when you move the arm down (Keep in mind there is an 20 second delay) and the Air spring inflates, the sensor is operating in the wrong direction. You can fix this problem without remounting the sensor by swapping the blue and green wires in the harness at the sensor. To do this, with the truck turned off, simply unplug the harness from the sensor. Using a small screwdriver pop the purple retainer out of the plug by prying up on each end of it. After removing the retainer if you look into the end of the plug you will see a tang holding each wire terminal. Simply pry it down just enough to release the terminals of the blue and green wires. Swap the blue and green wire position and reinstall the wires into the plug paying attention to the direction of the small tab on the wire terminal. This tab will point to the center of the plug. Push the wire terminals into the plug making sure they catch on the tang and reinstall the purple retainer. After plugging the sensor back in you can confirm correct operation by turning the truck back on moving the sensor arm up, the Air spring should inflate. If the system is functioning correctly, shut the truck off and reattach the linkage.

