

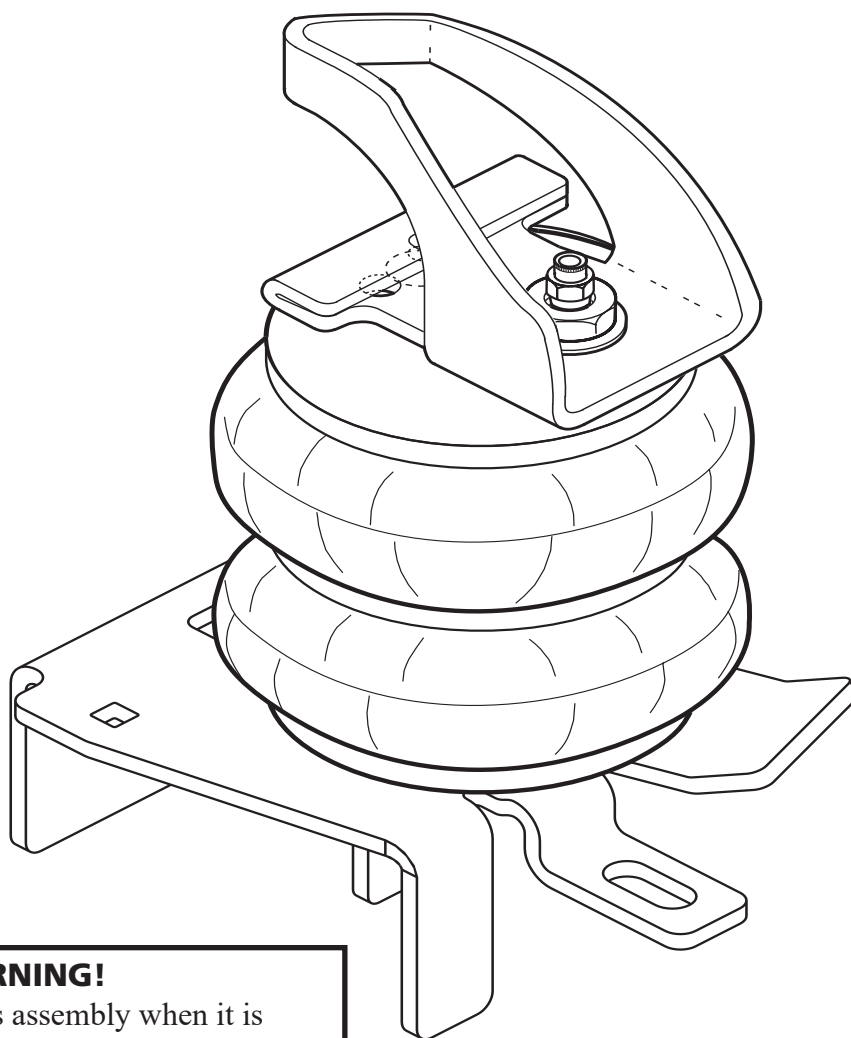

81224023 2014-2016 F450 LEVELTOW KIT

Congratulations - your new TowPro Helper Springs are quality products capable of improving the handling and comfort of your vehicle. As with all products, proper installation is the key to obtaining all of the benefits your kit is capable of delivering. Please take a few minutes to read through the instructions to identify the components and learn where and how they are used. It is a good idea to start by comparing the parts in your kit with the parts list below.









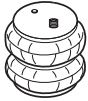

WARNING!

Do not inflate this assembly when it is unrestricted. The assembly must be restricted by the suspension or other adequate structure. Do not inflate beyond 100 P.S.I. Improper use or over inflation may cause property damage or severe personal injury.

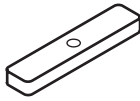

PARTS

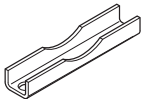
Compare the parts below to your kit. Assure you have all pieces, and organize them for an easier installation.















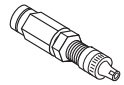

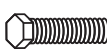
MAIN KIT CONTENTS

PART # 7701		x 2 AIR SPRING	PART # 5809		x 1 LEFT LOWER BRACKET	PART # 5477		x 2 1/2" SPACER
PART # 5717		x 1 LEFT SIDE UPPER BRACKET	PART # 5810		x 1 RIGHT LOWER BRACKET	PART # 1004		x 1 HEAT SHIELD
PART # 5572		x 1 RIGHT SIDE UPPER BRACKET	PART # 5613		x 2 AXLE STRAP BRACKET	PART # 9415		x 1 AIR LINE TUBE (22 FEET)

A24-760-7560 INFLATION VALVE BRACKET KIT

PART # 9483		x 1 NO-DRILL INFLATION VALVE BRACKET	PART # 9488		x 2 LARGE NYLON TIE
-------------	---	--------------------------------------	-------------	--	---------------------

A21-760-2583 HARDWARE PACK

PT # 3029		x 1 3/8" - 16 x 1 1/2" HEX HEAD BOLT	PT # 3067		x 7 3/8" - 16 FLANGE LOCK NUT	PT # 3296		x 1 3/4" LOCK WASHER
PT # 0071		x 1 3/8" FLAT WASHER	PT # 0632		x 2 3/8" LARGE FLAT WASHER	PT # 3032		x 2 INFLATION VALVE AND VALVE CAP ASSEMBLY
PT # 3033		x 4 5/16" FLAT WASHER	PT # 3409		x 1 3/4" - 16 x 1 1/4" HEX HEAD BOLT	PT # 3046		x 2 AIR FITTING
PT # 3411		x 1 3/4" THICK WASHER	PT # 3295		x 2 3/4" - 16 HEX NUT	PT # 3428		x 4 3/8" - 16 x 9" CARRIAGE BOLT
PT # 0681		x 4 3/8" - 16 x 3/4" HEX HEAD BOLT	PT # 3412		x 1 3/4" - 16 FRAME NUT	PT # 9036		x 6 RED NYLON TIE
PT # 3345		x 2 3/8" - 16 x 2 1/2" FLAT HEAD BOLT	PT # 3064		x 2 INTERNAL TOOTH LOCK WASHER	PT # 0899		x 2 THERMAL SLEEVE

CONTENTS AND OVERVIEW

PAGE 4 REMOVE JOUNCE BUMPER & INSTALL UPPER BRACKET

PAGE 5 FASTEN AIR SPRING TO UPPER BRACKET

PAGE 6 INSTALL LOWER BRACKET

PAGE 7 SECURE LOWER BRACKET

PAGE 8 INSTALL RIGHT SIDE UPPER BRACKET

PAGE 9 HEAT SHIELD & RIGHT SIDE

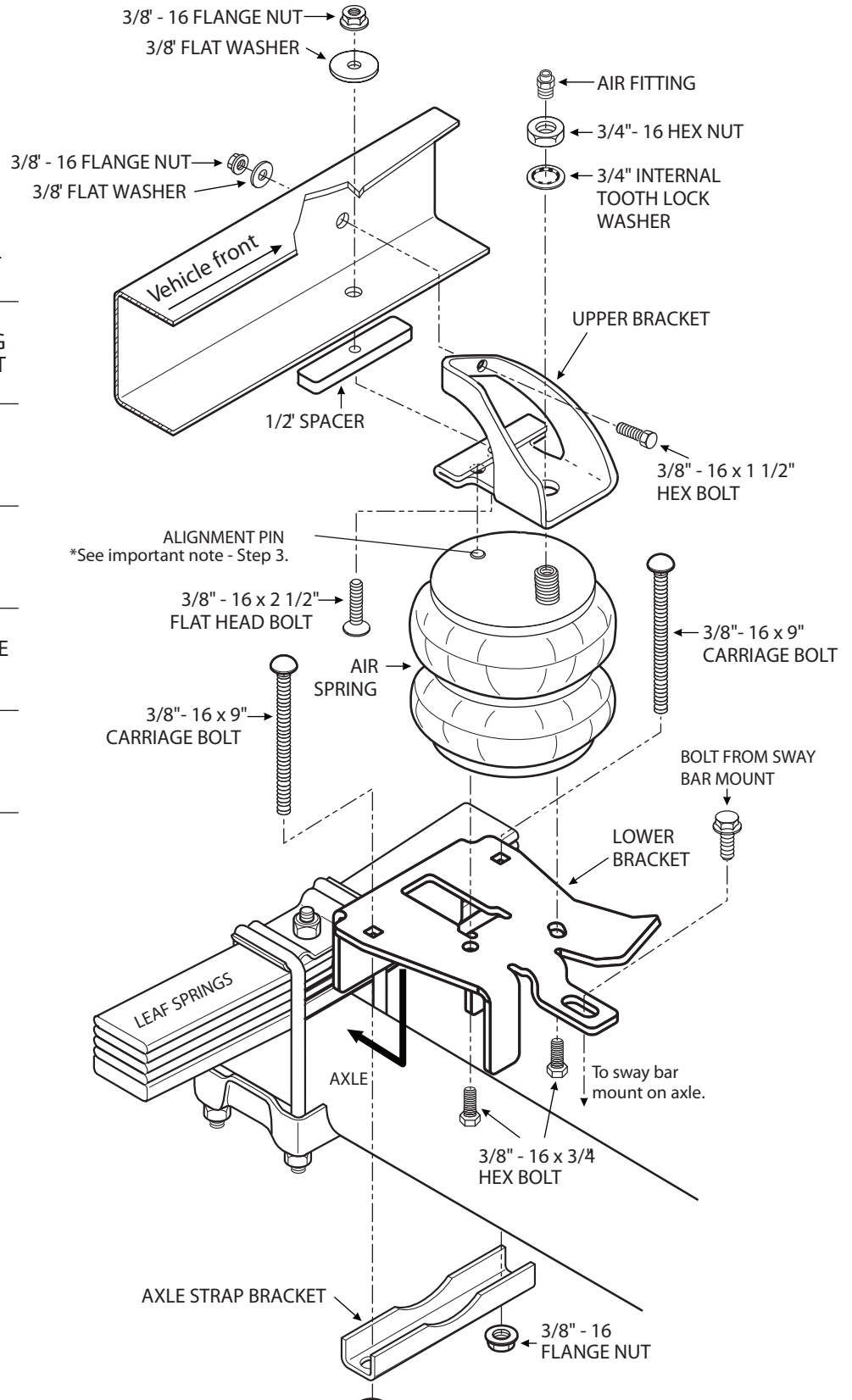

REMOVE EXISTING JOUNCE BUMPER

1

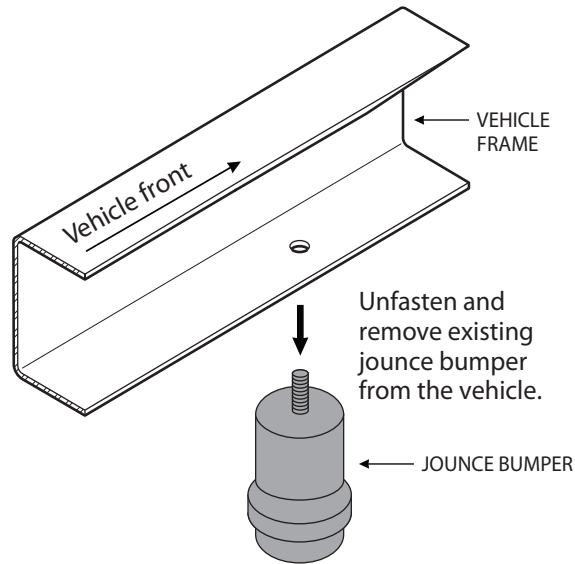

INSTALL LEFT SIDE UPPER BRACKET

2

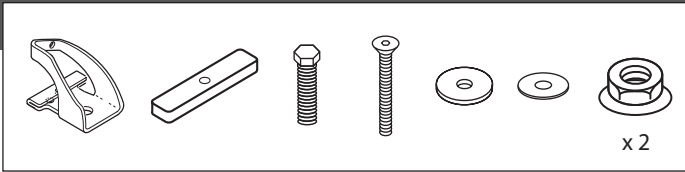

ASSURE NO WIRING OR LINES ARE PINCHED BETWEEN THE BRACKET AND FRAME.

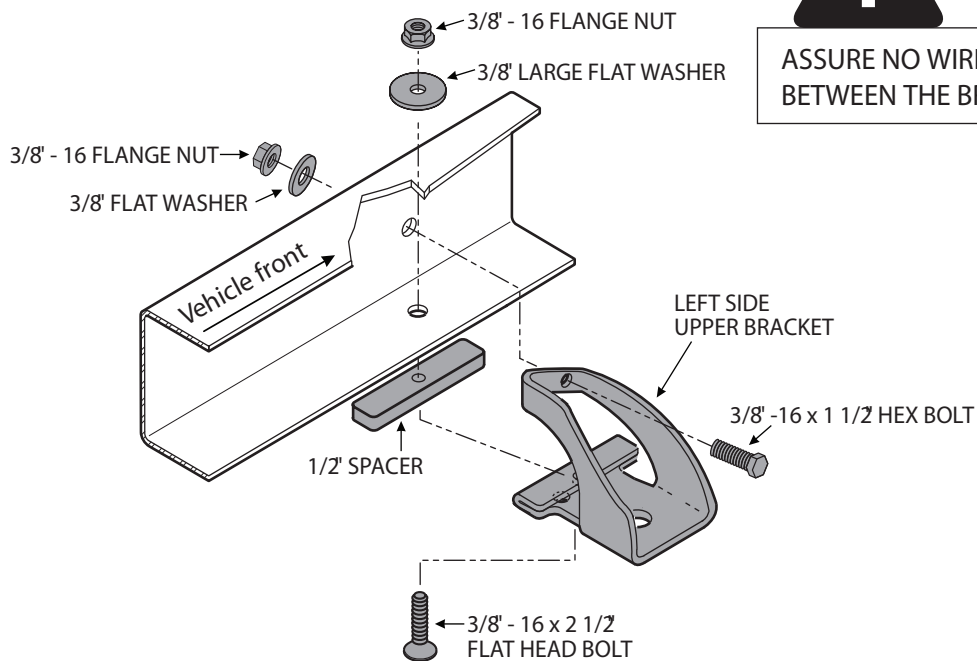

3

FASTEN AIR SPRING TO UPPER BRACKET

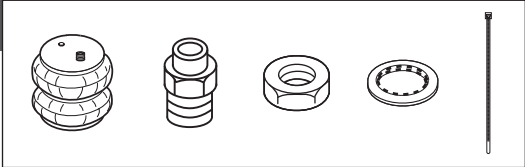

INSTALLING THE RIGHT SIDE? REMEMBER TO INSTALL THE HEAT SHIELD IN STEP 7 FIRST!

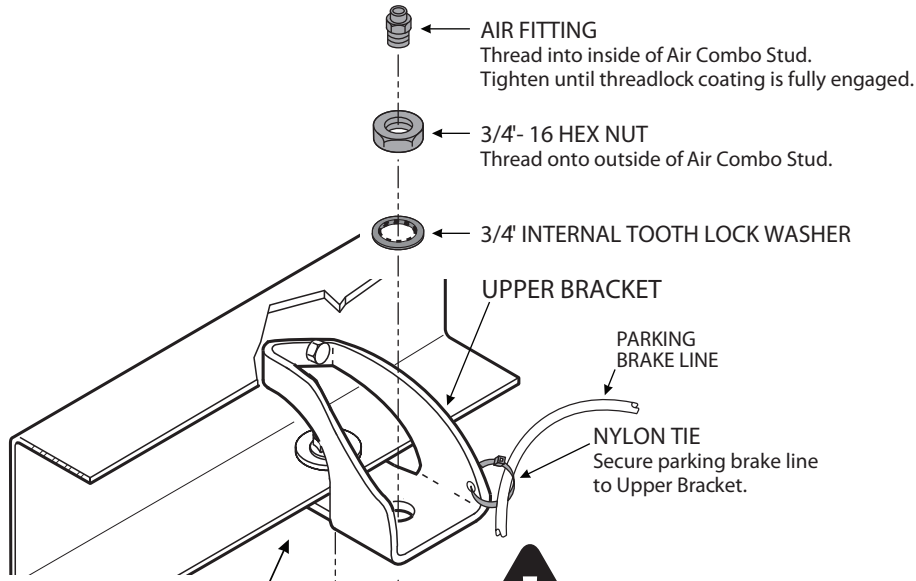

VIEW FROM BELOW

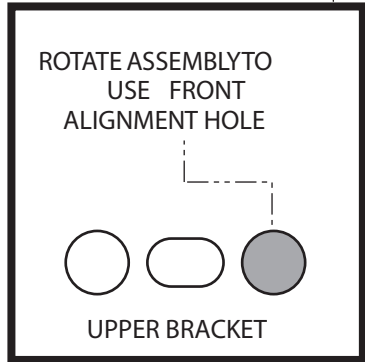

ALIGNMENT PIN ON AIR SPRINGS MUST BE INSTALLED TO FULLY SEAT INTO THE FRONT ALIGNMENT HOLE IN THE UPPER BRACKET. FAILURE TO DO SO WILL CAUSE IT TO BE PUSHED INTO THE BEAD PLATE, CREATING AN AIR LEAK, AND RESULTING IN AN AIR SPRING FAILURE THAT IS NOT WARRANTABLE. THE ALIGNMENT PIN CANNOT HOLD 2,500 LBS! IT IS USED FOR ALIGNMENT ONLY!

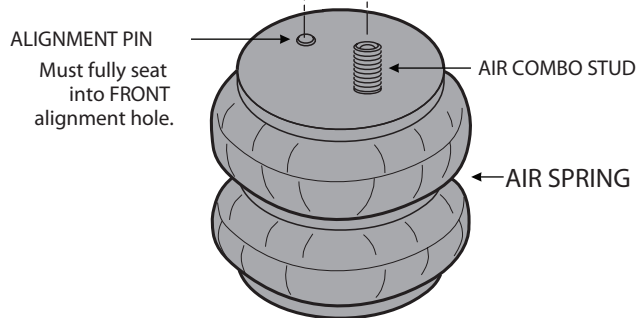

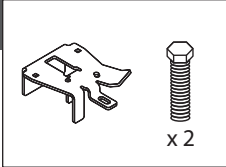

1 Remove the existing Sway Bar bolt from the mount. **KEEP THIS BOLT.**

2 Fasten the Lower Bracket to the Air Spring as shown. Hand-tighten for now.

3 Set the Lower Bracket into position on the axle, as close to the leaf spring stack as possible. Assure the tab on the Lower Bracket can be fastened to the sway bar mount with the existing bolt.

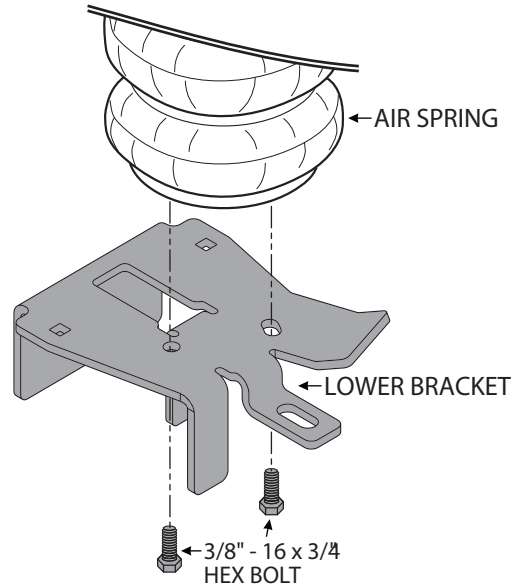

4 Dry fit the assembly and make alignment marks, as shown.

5 Align the alignment marks and securely fasten the Lower Bracket to the Air Spring. Use the existing sway bar mount bolt to fasten the tab on the Lower Bracket to the sway bar.

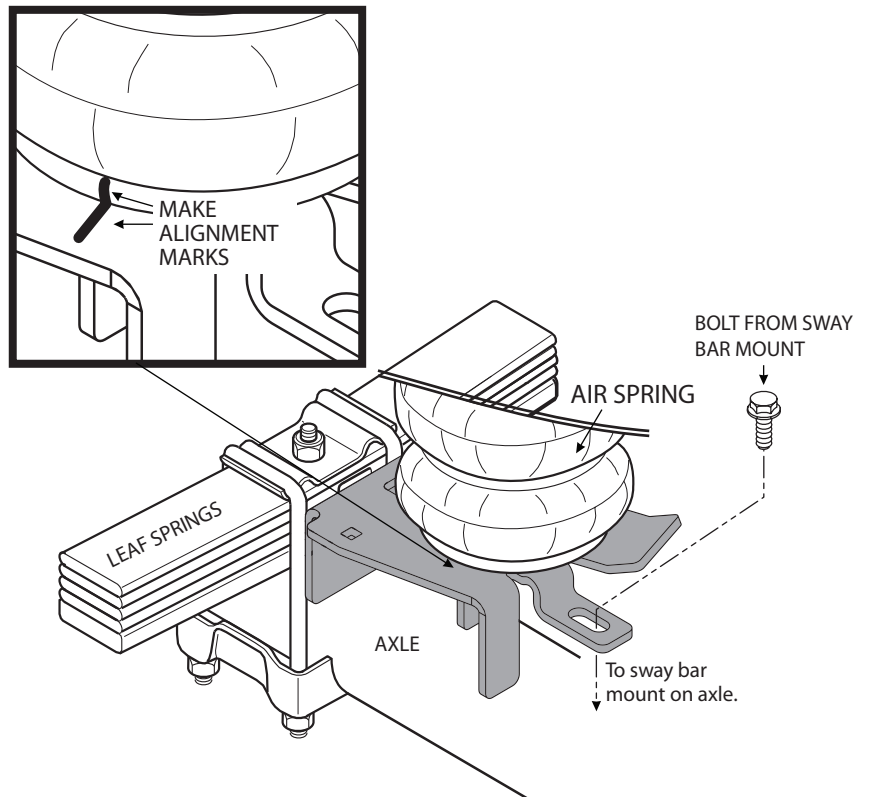

5

SECURE LOWER BRACKET

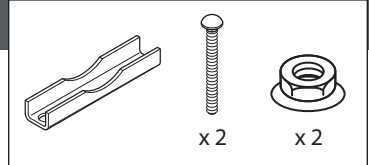

USE YOUR HAND TO CHECK FOR THE PROPER CLEARANCE AROUND THE AIR SPRING. IF YOUR HAND DOES NOT FIT BETWEEN THE AIR SPRING AND OTHER COMPONENTS, IT WILL RUB!

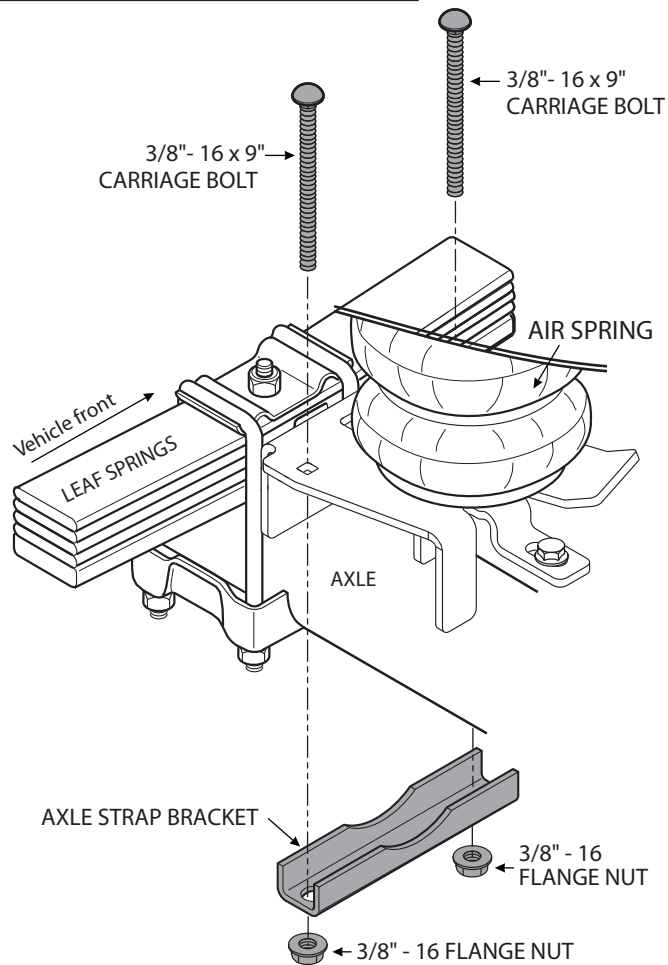

Alternate tightening to draw Axle Strap Bracket evenly to the axle.



AWESOME! You're done with the left side. Move on to Step 6 to begin the right side installation.

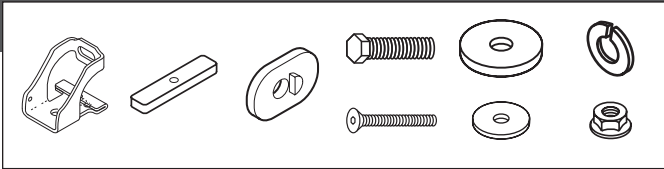

1 Follow the steps below to install the right side Upper Bracket.

2 Once completed, see Step 7 for Heat Shield Installation.

3 Once Step 7 is complete for the right side, continue to Steps 3-5.



ASSURE NO WIRING OR LINES ARE PINCHED BETWEEN THE BRACKET AND FRAME.

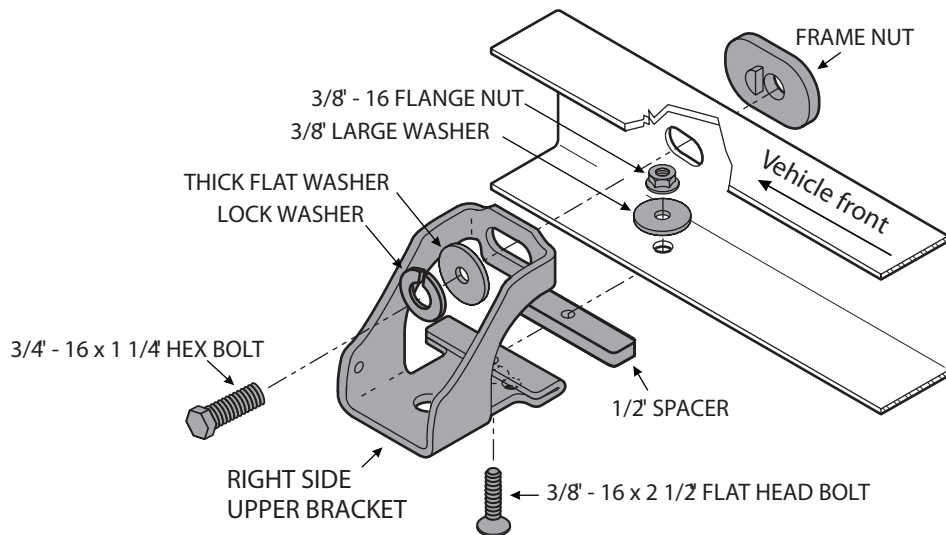

7

INSTALL RIGHT SIDE WITH HEAT SHIELD

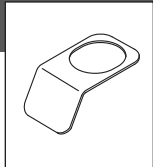

RIGHT SIDE INSTALLATION MUST INCLUDE HEAT SHIELD!

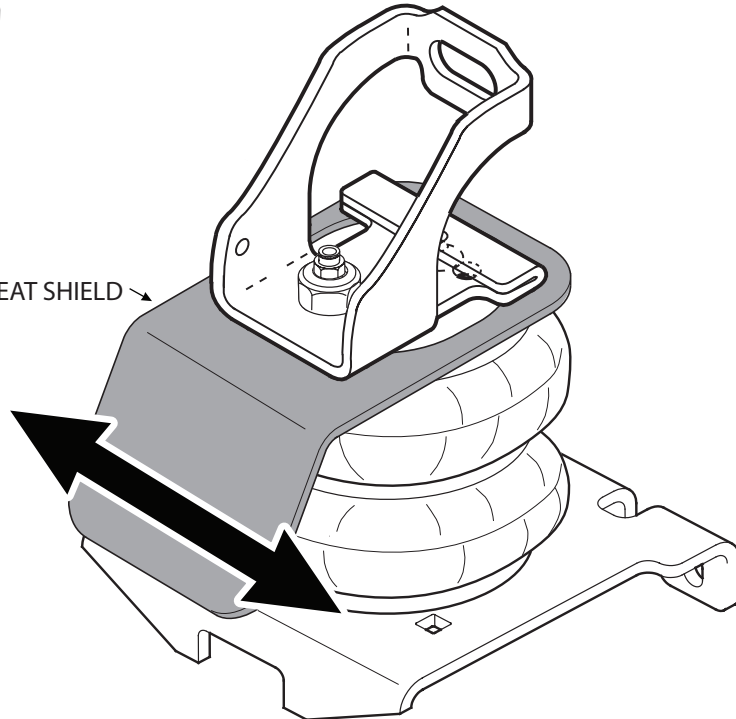
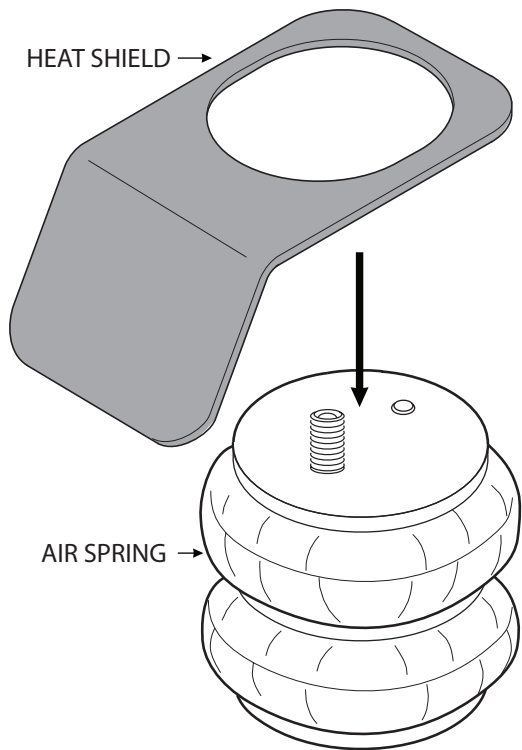

Position Heat Shield to
closest point of exhaust.
DO NOT PLACE
DIRECTLY ABOVE AXLE.

LevelTOW

ADVANCED TOWING SOLUTIONS
by ridetech

LevelTow Compressor System

Congratulations - your new LevelTow Compressor System is a quality product, that when used in conjunction with the LevelTow helper Air Springs, is capable of improving the handling and comfort of your vehicle. As with all products, proper installation is the key to obtaining all of the benefits your kit is capable of delivering. Please take a few minutes to read through the instructions to identify the components and learn where and how they are used. It is a good idea to start by comparing the parts in your kit with the parts list below.

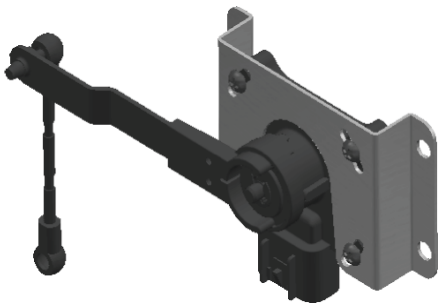

Components:

	Part #	QTY
Compressor Unit	31920022	1
Smart Sensor Height Sensor	31980006	1
Compressor Mounting Bracket	90002637	1
Smart Sensor Mounting Bracket	70014456	1
Sensor Linkage	31980011	1
Linkage Axle Bracket	70011429	1
Control Panel Bracket	70011439	1
Airline Fitting (mounted in compressor)	31957016	1
Main Activation Switch	35970000	1
Manual Control Switch	70011413	1
Main Wire Harness	31900051	1
Axle Bracket Clamp	99000005	1
1/4" TEE Fitting	31954400	1
1/4" Fitting for airsprings Straight / 90 Degree	31954000 / 31954201	2
20 amp fuse	90001922	1
Fuse Holder	90001924	1
10-12 Butt Connector for Fuse Holder	90001913	1
Ring Terminal for Main Power Hookup	90001916	1

Hardware:

#10 x 5/8" Phillips pan head - sensor to bracket	99104002	4
1/4"-14 x 1" Self Drilling Screw- Sensor to Frame	99254001	5
3/8-16 x 1" Thread Forming - Compressor Bracket to Frame	99373007	4
10-24 x 1 1/4" Maching Screw - Compressor to Bracket	99101007	4
10-24 Nylok Nut - Compressor to Bracket	99102002	4
#10 Flat Washer - Compressor to Bracket	99103001	8

The LevelTow Compressor System is an automatic leveling system, once it is turned on (button illuminated blue) it will operate without any assistance.

The Smart sensor supplied with the compressor system will tell the system to inflate or deflate to keep the vehicle level. It has a dwell range built in so that when the truck is going down the road hitting small defects the system will be idle. It isn't until the sensor gets out of this dwell range for 18 seconds that the system will react.

The activation switch has to be illuminated blue for the system to work.

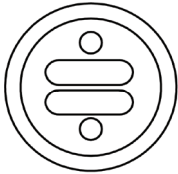

Activation Button

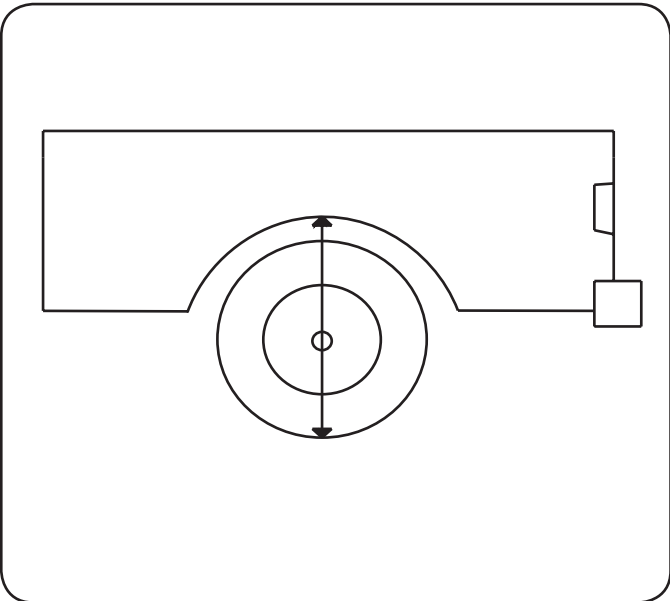

1. Before you install the compressor system, you will need to have the helper Airsprings installed. This will ensure that the LevelTow linkage does not get in the way of the Airsprings.

The first step to doing the install, with the vehicle at ride height, measure the lip of the fender to the ground at the center of the wheel and write it down.

Measurement _____

This measurement will be used as a reference once you have the compressor system installed.

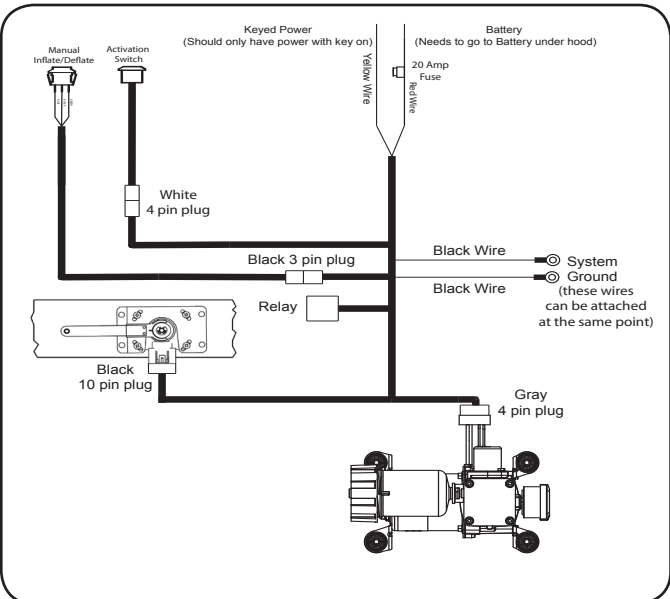

2. Unpack the wiring for the LevelTow system and lay it out. This will give you an idea to where you can mount the components without having to modify the wiring harness.

NOTE:
There is a wiring diagram on Page 7 to assist you in component location.

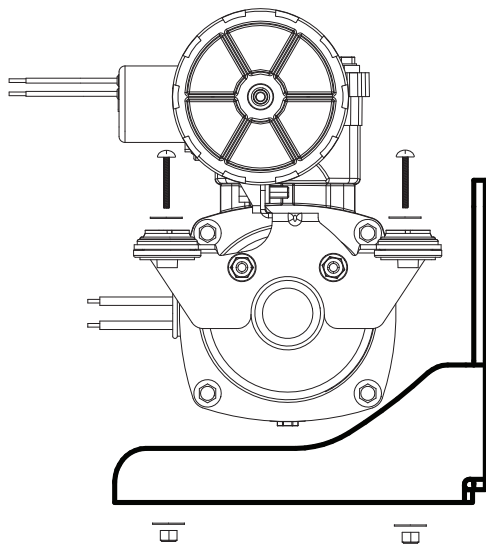

3. Bolt the compressor to the bracket. Position the compressor on the Bracket in the orientation shown. Line up the holes in the (4) Mounting Bushings with the (4) holes in the Bracket. Install a #10 Flat Washer on each of the (4) #10-24 x 1 1/4" Pan Head Screws. Insert a Screw/Washer in each of the 4 holes. Install a #10 Flat Washer on the threads sticking through the bottom of the bracket followed by a #10-24 Nylok Nut. Tighten the hardware.

NOTE:

The diagram shows the position the compressor goes onto the plate.

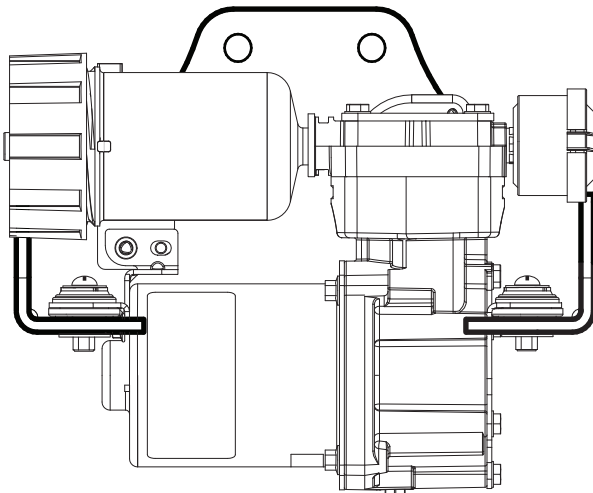

4. The compressor needs to be mounted on the frame rail with the dryer up. Attach the compressor bracket to the frame with (4) 3/8"-16 x 1" Thread Forming Bolts supplied in the kit. Drill a 5/16" Hole for the bolts.

NOTE:

Before drilling any hole be sure to check and see if there are any brake lines, fuel lines, or wires on the other side of the surface you are drilling.

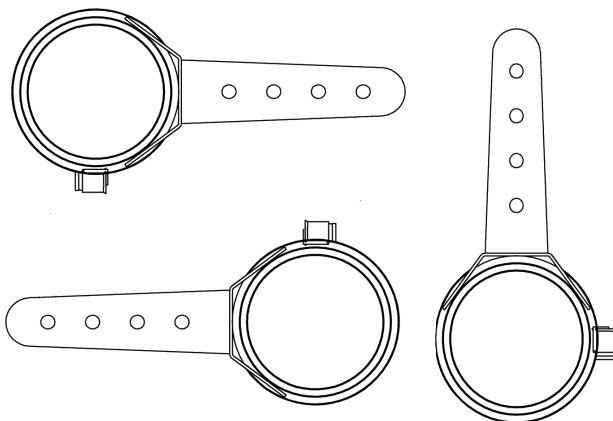

5. The Axle bracket can be mounted in any location on the axle tube to get the sensor linkage to line up. The Axle mount should be mounted on the axle so that the linkage will line up from the axle mount to the sensor. Keep this in mind when establishing the sensor location.

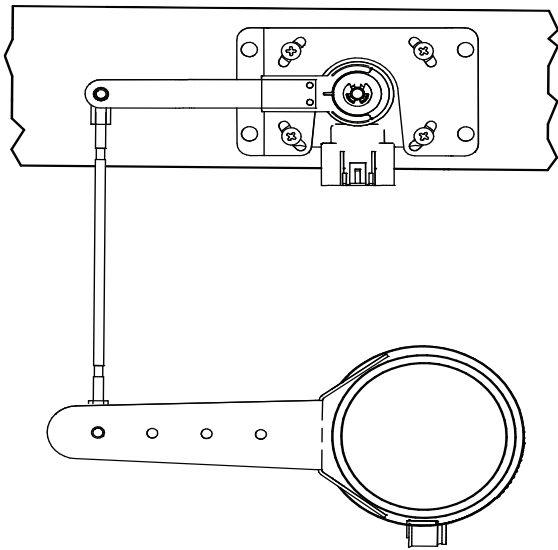

6. The next step will be to mount the sensor. The Smart Sensor needs to be centered in its travel at the trucks ride height to operate properly. This can be done by cutting the linkage rod to length. It can be fine tuned by loosening the 4 sensor mounting screws and twisting it in the mount and retightening the 4 screws. When the mounting and linkage is done it should look like the diagram seen here.

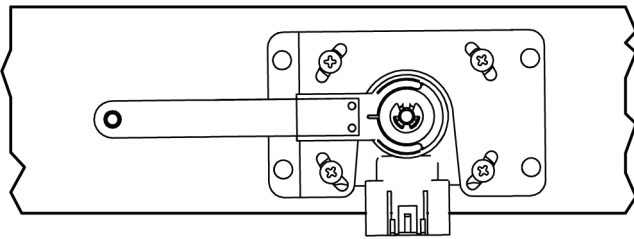

7. The sensor needs to be mounted on the frame rail with the wires pointing down. The arm will need to swing up opposite the direction of the wires as the suspension is being compressed. Attach the sensor bracket to the frame with (4) self drilling screws supplied with the kit.

NOTE:

The sensor can be mounted on the inside or outside of the frame. Make sure the linkage and arm can go through its entire travel without hitting any obstructions

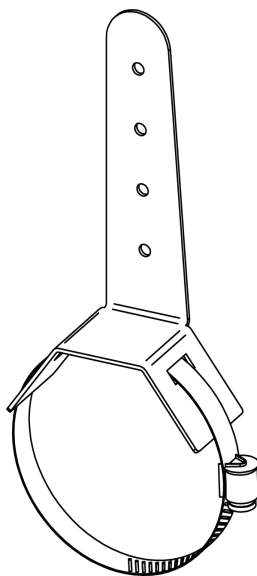

8. This diagram shows how the clamp sticks through the axle bracket. Loosen the clamp until it will open up and then slide it through the bracket. The whole assembly can then be put on the axle tube. Reinsert the end of the clamp back into the adjuster and tighten the clamp until the bracket is tight on the axle tube.

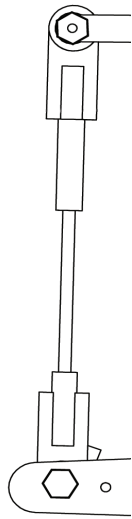

9. With the sensor and the axle bracket mounted, it is time to connect the 2 with the supplied linkage. The linkage is a universal length and will have to be cut to achieve the necessary length for your application. To do this it will be necessary to have the truck sitting at its factory ride height. With the truck at ride height center the sensor in its travel. The rod can slide into each rubber rod end up to 1”.

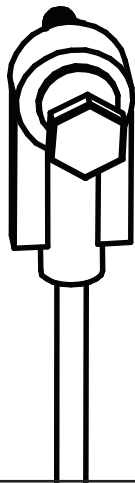

10. The linkage rod has barbs on the outside of it to keep it in the end link. After you push the ends in, they are difficult to pull back out. Push the linkage into the ends a little at a time until you get the desired length of the linkage assembly. If for some reason you must pull the rod out of the end, it is best done by twisting the end while pulling on it.

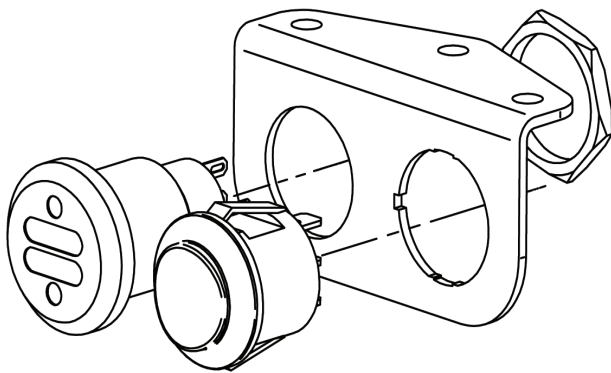

11. Mount the control panel in a convenient location. Install the Power Button and Manual Control Rocker into the panel. The Power Button gets installed into the round hole. The nut that is on the button is used to attach the button in the panel. The Rocker Switch goes into the hole with the notch in it. Align the tab on the switch with the slot and push the switch into the hole until it snaps in place. The rocker will only go into the hole one way. You can also custom mount the buttons if desired. They both use a 3/4” hole. The hole for the manual switch will have to have a slot for the tab

TOP

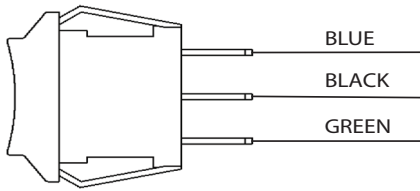

12. Hook the wires up to the manual control switch as shown in the diagram.

Green Wire-Manual Inflate
Black Wire -Switch Supply
Blue Wire - Manual Deflate

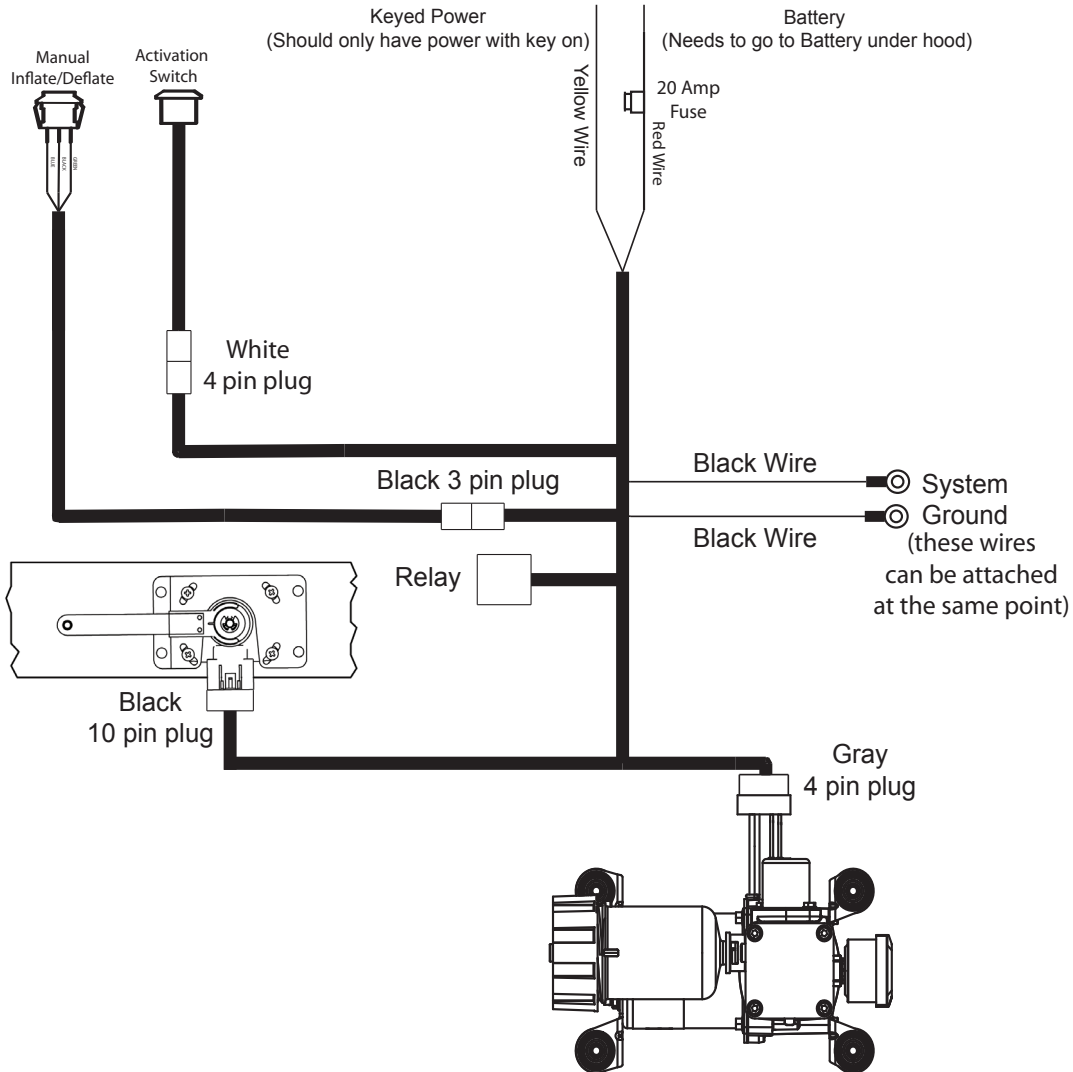

Red Wire - This wire needs to go straight to the **Battery** with the fuse holder installed within 18" of the Battery

Yellow Wire - This wire needs to go to a switched 12 volt power source. This wire should only have power when the key is on.

Black Wires - These wires go to a chassis ground. They can go to one of the screws attaching the compressor to the frame.

Relay - Will need to be attached to the frame with a self drilling screw supplied in the kit..

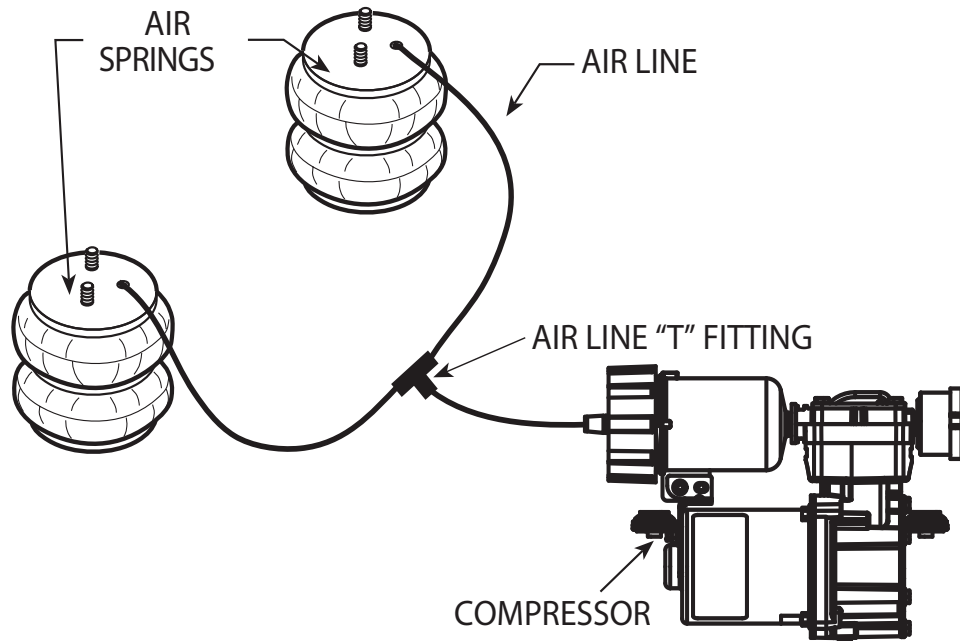

13. **Uncoil the airline being careful not to kink or flatten the line.** Start at the Airspring furthest from the compressor. Trim the airline so that the cut is clean and as square as possible. Insert the end of the airline into the fitting pushing it in as far as possible. Route the airline from the airspring to the compressor keeping it away the exhaust pipe and sharp edges. If it is necessary to run the line over a sharp edge, use a supplied thermal sleeve over the airline to protect it. The sleeve is installed by sliding it over the airline to the area where the line needs protected. **The airline should not be bent or curved sharply, this can cause the line to buckle or kink.** Secure the airline in place using the Zipties provided in the kit. Once the first airspring line is ran to the compressor, trim off the excess and use it for the remaining air spring line to the compressor. With both lines ran from the air spring to the compressor, install the "T" fitting on the lines and run the remaining side of the "T" fitting to the compressor fitting.

TIP: Wetting the end of the airline before sliding it into the fitting makes it easier to install into the fitting.

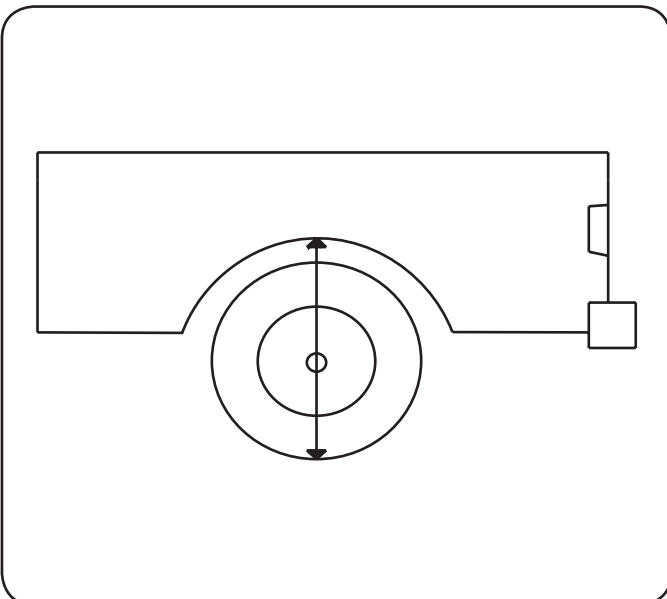

14. Once the system is installed you can verify the operation of the system by putting a load on the truck. With a load on the truck and the button illuminated blue, your fender to ground measurement that you took on the first step should be the same. If it is higher or lower you can adjust the height by loosening the 4 screws that attach the sensor to the bracket and twist in its mount. If ride height can not be achieved by adjusting in the bracket the linkage will need to be lengthened or shortened to achieve the height you need.

Manual Operation:

The LevelTow Compressor System also has a manual control function. This function allows you to manually inflated or deflate the system. To use the manual function you must first turn the system off by pushing the main power button. Once the system is turned off you can push the rocker switch up to inflate or down to deflate. To put the system back in level mode push the main power switch to turn it back on.

Note:

If the Activation Button is illuminated blue and the manual button is pushed the truck will relevel itself. The activation button has to be off for the manual control to be used and the truck remain at the height.

Troubleshooting:

If after installation you find the system not functioning correctly, you may have the sensor operating the wrong direction. You can verify this by turning the truck on and check that the activation button is illuminated blue. Unhook one end of the linkage and move the sensor arm by hand. If when you move the arm down (Keep in mind there is an 20 second delay) and the Air spring inflates, the sensor is operating in the wrong direction. You can fix this problem without remounting the sensor by swapping the blue and green wires in the harness at the sensor. To do this, with the truck turned off, simply unplug the harness from the sensor. Using a small screwdriver pop the purple retainer out of the plug by prying up on each end of it. After removing the retainer if you look into the end of the plug you will see a tang holding each wire terminal. Simply pry it down just enough to release the terminals of the blue and green wires. Swap the blue and green wire position and reinstall the wires into the plug paying attention to the direction of the small tab on the wire terminal. This tab will point to the center of the plug. Push the wire terminals into the plug making sure they catch on the tang and reinstall the purple retainer. After plugging the sensor back in you can confirm correct operation by turning the truck back on moving the sensor arm up, the Air spring should inflate. If the system is functioning correctly, shut the truck off and reattach the linkage.

