



Part # 13040311

Mopar LX Platform CoilOver System – TQ Series
05-08 Magnum / 05-Up 300C / 06-Up Charger / 08-Up Challenger

Front Components:

1 13043111 Front TQ Series CoilOvers

Rear Components:

1 13046111 Rear TQ Series CoilOvers

Components:

1 85000000 CoilOver Spanner Wrench



Part # 13043111

Mopar LX Platform Front CoilOver – TQ Series

05-08 Magnum / 05-Up 300C / 06-Up Charger / 08-Up Challenger

Shock:

2	24659999	5" stroke shock w/ threaded bottom – TQ Series
2	90002357	Aluminum Reducer Puck
2	90009986	2" Stud top (Stud top base not needed)
2	90001668	Aluminum lower shock mount
2	90009980	Narrow Lower Shockwave steel bracket

Components:

2	59120325	12" 325lb Coilspring
4	90002229	Steel washer for rubber mount (2.375" O.D.)
2	90001974	Upper rubber isolator
2	90001973	Lower rubber isolator (T-shaped)
2	90001971	Aluminum upper ShockWave plate
2	90002222	Spring Retainer kit
2	90002448	Wide Lower Shockwave steel bracket
4	90002221	Reservoir Mount
1	85000003	Allen Wrench

Hardware:

2	99562003	9/16"-18 Nylok jam nut	Stud top to upper mount
2	99561008	9/16"-18 x 3 1/4" bolt	NARROW Lower bracket to lower arm
2	99561009	9/16"-18 x 4" bolt	WIDE Lower bracket to lower arm
2	99562001	9/16"-18 Nylok nut	Lower bracket to lower arm
6	99371006	3/8"-16 x 1 1/2" bolt	Aluminum plate to body
6	99372001	3/8"-16 Nylok nut	Aluminum plate to body
12	99373003	3/8" SAE washer	Aluminum plate to body
2	99501029	1/2"-13 x 6 1/2" Bolt	Lower Shock Mount to Shock
2	99503002	1/2" Split Lock Washer	Lower Shock Mount to Shock
1	90002263	Red Loctite Tube	Lower Mount Assembly
12	99050000	5mm SHCS	Reservoir Mount

Mopar LX Front CoilOver Assembly

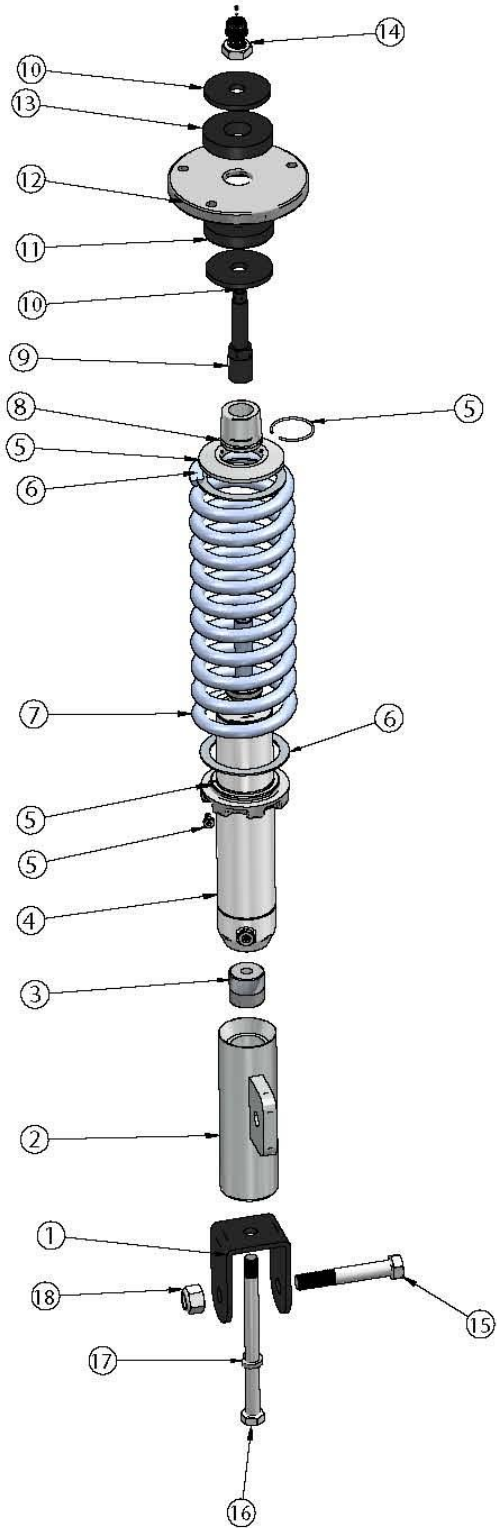

Item Number	Description	Qty.
1	Lower Steel Shockwave Bracket-90009980 or 90002448	2
2	Bottom lower billet mount 90001668	2
3	Aluminum Reducer Puck 90002357	2
4	5.2" Shock w/ universal bottom - 24559999	2
5	Coil spring Retainer kit 90002222	2
6	Delrin Spring Washer 70010828	4
7	12" 325 lb Coil spring 59120325	2
8	Stud Top Spacer 90002442	2
9	Short stud top 90009988	2
10	Washer for Rubber Mount 90002229	4
11	Lower Rubber Isolator(T-shaped)90001973	2
12	Upper mounting plate 90001971	2
13	Upper Rubber Isolator 90001974	2
14	9/16" SAE jam Nylok nut	2
15	9/16" X 3 1/2" or 4" Bolt	2
16	1/2"-13 x 6 1/2" USS bolt	2
17	1/2" Lock Washer	2
18	9/16"-18 Nylok Nut	2

COILOver

Installation Instructions

1. Raise the vehicle to a safe and comfortable working height with the suspension hanging freely.
2. Remove the factory struts and upper mounts; refer to the service manual for proper disassembly procedures.
3. Due to 2 possible lower mount options on this platform, included in the kit are 2 different widths of lower mounts.
4. Determine the width of Lower Mount required for your application by test fitting the supplied mounts. Refer to the diagram below for assembly and clocking of the lower bracket.

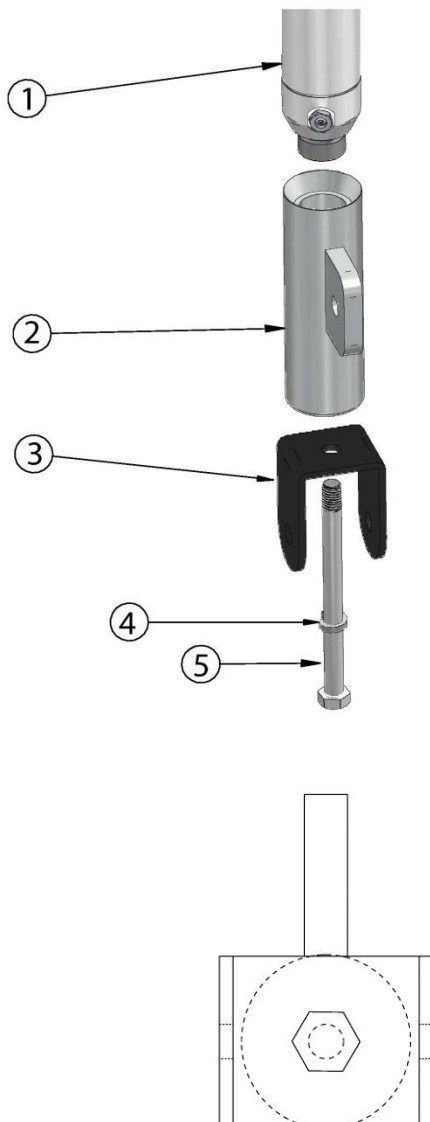

1. Shock Assembly
2. Lower Shock Adapter
3. Lower Shock Mount
4. 1/2" Split Lock washer
5. 1/2" x 6 1/2" Hex Bolt

Assembly

1. Slide the Shock Adapter onto the Shock Assembly.
2. Install the Split Lock washer onto the 1/2" x 6 1/2" Bolt.
3. Apply Red Loctite onto the threads of the bolt.
4. Insert the Bolt through the Lower Shock Mount and into the bottom hole of the Shock Adapter.
5. Thread the bolt into the Shock. **The Lower Shock Mount has to be clocked so that the Shock Mount Tabs run parallel with the Sway Bar Mount on the Adapter.** The diagram here shows correct clocking of the bracket.
6. With the bracket clocked correctly, tighten the 1/2" Bolt.

COILOver

Installation Instructions

5. Assemble the CoilOver using the drawing on the Page 3 as a reference.



6. Bolt the aluminum upper plate to the car in place of the factory rubber mount using the 3/8" x 1 1/4" bolts, flat washer and Nylok nuts.

Note: The recessed side of the plate must face down.

7. Place one of the 2.375" steel washers over the threaded stud. Then slide the T shaped rubber bushing over the stud. Place the Shockwave into the coil spring pocket with the stud protruding through the hole in the aluminum plate.



8. From the engine bay, place the other rubber bushing over the stud, then another steel plate. Secure the assembly with a 9/16" SAE Nylok Jam nut. **Note:** Some cars may have a plastic cover in the engine bay that may need to be clearance for the adjustment knob.

9. With the Sway Bar tab pointing to the inside of the car, Bolt the bottom of the Coilover assembly to the lower arm using a 9/16" x 3 1/2" bolt and Nylok nut.

10. Attach sway bar to Coilover using the factory hardware.

COILOver



11. Ride height on this car is approximately 2" lower than factory.



Part # 13046111
Mopar LX Platform Rear CoilOver – TQ Series
05-08 Magnum / 05-Up 300C / 06-Up Charger / 08-Up Challenger

Shock:

2	24259999	5.2" stroke shock TQ Series
2	90002156	4.7" Eyelet
2	90001995	Bearing Snap Ring
2	90001994	.625" ID Bearing

Components:

2	59100325	10" 325lb Coilspring
2	90002229	Steel washer for rubber mount
2	70010949	Upper rubber isolator
2	90001973	Lower rubber isolator (T-shaped)
2	90002369	Rubber Bushing Housing
1	90002738	Upper Shock plate- Driver
1	90002739	Upper Shock plate- Passenger
2	90002222	Spring Retainer kit
2	90002070	Drop Spring Cap
2	90009982	Upper Shock Mount
4	70010828	Delrin Spring Washers
4	90002043	Upper Bearing Spacers (Narrow)
4	90002443	Lower Bearing Spacers (Wide)
4	90002221	Reservoir Mount

Hardware:

4	99502001	1/2"-13 Nylok Nut	Shock Mounting
4	99501003	1/2"-13 x 2 1/2" Bolt	Upper Shock Mount
2	99503007	1/2" x 1 1/2" OD Flatwasher	Upper Shock Mount
12	99050000	5mm SHCS	Reservoir Mount
8	99251017	1/4"-20 x 1/2" Low Head SHCS	Upper Mount to Plate

Mopar LX Rear CoilOver Assembly

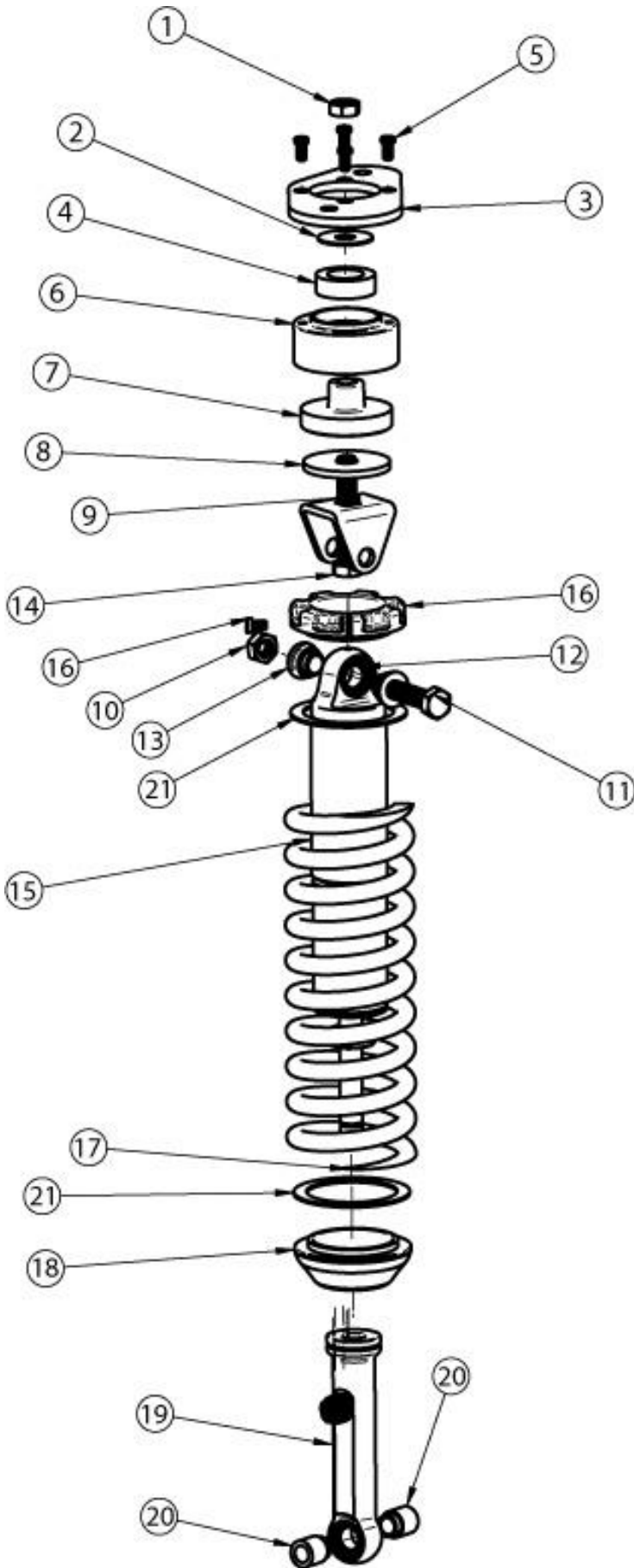

Item Number	Description	Qty.
1	1/2"-13 Nylock Nut 99502001	2
2	9/16" Flatwasher 99563001	2
3	Upper Mounting Plate 90002738 Driver	1
3	Upper Mounting Plate 90002739 Passenger	1
4	Upper Rubber Isolator 70010949	2
5	1/4"-20 x 1/2" Low Head SHCS 99251017	8
6	Aluminum Upper Mount 90002369	2
7	Lower Rubber Isolator 90001973	2
8	Isolator Washer 90002230	2
9	Upper Shock Mount 90009982	2
10	1/2"-13 Nylok Nut 99502001	2
11	1/2"-13 x 2 1/2" hex Bolt 99501003	2
12	625" ID Bearing 90001994	4
13	Upper Bearing Spacer 90002043	4
14	1/2"-13 x 3" hex Bolt 99501004	4
15	5.2" Stroke TQ Shock 24259999	2
16	Coilspring Retainer kit 90002222	2
17	10" 325lb Coil Spring 59100325	2
18	Drop Coil Spring Cap 90002070	2
19	4.7" Eyelet 90002156	2
20	Lower Bearing Spacers 90002443	4
21	Delrin Spring Washers 70010828	4

COILOver

Installation Instructions

1. Raise the vehicle to a safe and comfortable working height with the suspension hanging freely.
2. Remove the factory springs, shocks and upper mounts; refer to the service manual for proper disassembly procedures. **Retain the factory upper hardware for reassembly.**
3. Assemble the CoilOver using the drawing on the previous page as a reference.

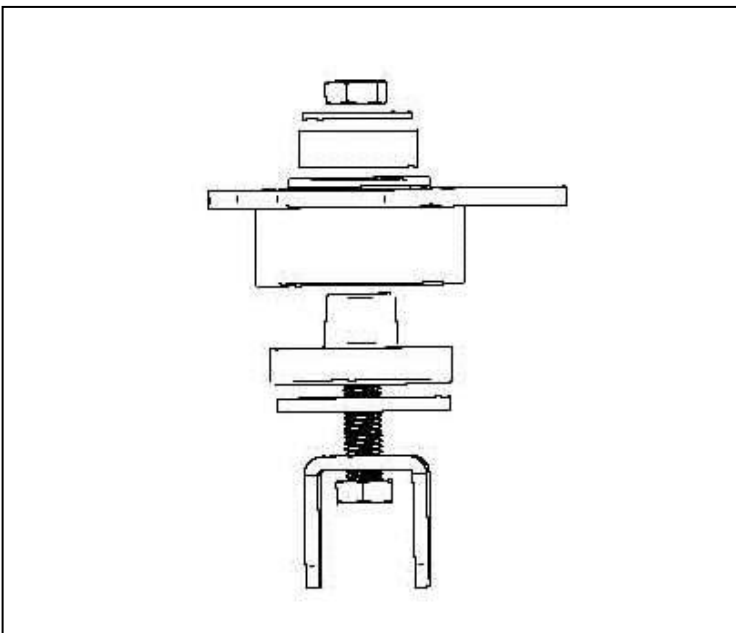

4. Assemble the upper shock mount using the illustration as a reference. **The upper shock bolt must run parallel with the lower shock bolt.**

Note: The upper shock bolt must run parallel with the upper shock bolt.

5. Assemble the spring onto the shock. Slide the upper mount over the eyelet. Install the retaining snap ring.



6. Install the CoilOver assembly into the upper mount with a narrow spacer in each side of the bearing. Attach it to the upper mount using a 1/2" x 2 1/2" bolt.

7. Bolt the assembly to the body of the car using the factory hardware.



8. Attach the eyelet to the lower control arm using a wide spacer in each side of the bearing. The Small OD of the Spacer is inserted into the Shock Bearing. Attach the Eyelet using the OEM Hardware.

Note: Locate the adjuster knob facing the wheel of the car.

Note: It may be necessary to trim the Threads sticking out of the Nut on the Swaybar Linkage.

Ride Height

We have designed most cars to have a ride height of about 2" lower than factory. To achieve the best ride quality & handling, the shock absorber needs to be at 40-60% overall travel when the car is at ride height. This will ensure that the shock will not bottom out or top out over even the largest bumps. Measuring the shock can be difficult, especially on some front suspensions. Measuring overall wheel travel is just as effective and can be much easier. Most cars will have 4-6" of overall wheel travel. One easy way to determine where you are at in wheel travel is to take a measurement from the fender lip (center of the wheel) to the ground. Then lift the car by the frame until the wheel is just touching the ground, re-measure. This will indicate how far you are from full extension of the shock. A minimum of 1.5" of extension travel (at the wheel) is needed to ensure that the shock does not top out. If you are more than 3" from full extension of the shock then you are in danger of bottoming out the shock absorber.

Adjusting Spring Height

When assembling the CoilOver, screw the spring retainer tight up to the spring (0 preload). After entire weight of car is on the wheels, jounce the suspension and roll the car forward and backward to alleviate suspension bind.

- If the car is too high w/ 0 preload then a smaller rate spring is required. Although threading the spring retainer down would lower the car, this could allow the spring to fall out of its seat when lifting the car by the frame.
- If the car is too low w/ 0 preload, then preload can then be added by threading the spring retainer up to achieve ride height. On 2.6" - 4" stroke shocks, up to 1.5" of preload is acceptable. On 5-7" stroke shocks, up to 2.5" of preload is acceptable. If more preload is needed to achieve ride height a stiffer spring rate is required. Too much preload may lead to coil bind, causing ride quality to suffer.

Shock adjustment 101- Single Adjustable

Rebound Adjustment:

How to adjust your new shocks.

The rebound adjustment knob is located on the top of the shock absorber protruding from the eyelet.

You must first begin at the ZERO setting, then set the shock to a soft setting of 20.



-Begin with the shocks adjusted to the ZERO rebound position (full stiff). Do this by rotating the rebound adjuster knob clockwise until it stops.



-Now turn the rebound adjuster knob counter clock wise 20 clicks. This sets the shock at 20. (settings 21-24 are typically too soft for street use).

Take the vehicle for a test drive.



-if you are satisfied with the ride quality, do not do anything, you are set!



-if the ride quality is too soft increase the damping effect by rotating the rebound knob clock wise 3 clicks.

Take the vehicle for another test drive.



-if the vehicle is too soft increase the damping effect by rotating the rebound knob clock wise 3 additional clicks.



-If the vehicle is too stiff rotate the rebound adjustment knob counter clock wise 2 clicks and you are set!

Take the vehicle for another test drive and repeat the above steps until the ride quality is satisfactory.

Note:

One end of the vehicle will likely reach the desired setting before the other end. If this happens stop adjusting the satisfied end and keep adjusting the unsatisfied end until the overall ride quality is satisfactory.