



**Installation
Instructions**



Part # 12150298 - 2005 Up Mustang Air Suspension System

Front Components:
 12152401 Front ShockWave Strut Instructions

Rear Components:
 12155401 Rear ShockWave Instructions

Recommended Tools

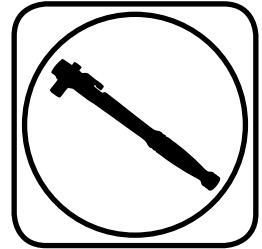

**2005 up Mustang Air Suspension System
Installation Instructions**

Table of contents
 Pages 2-7..... Front ShockWave
 Pages 8-14..... Rear ShockWave



Part # 12152401 -2005 up Mustang



Recommended Tools

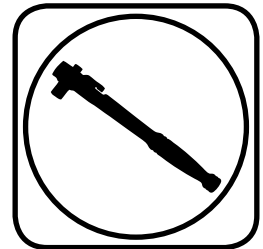

2005-up Mustang Front AirStrut Installation Instructions

Table of contents

- Page 3..... Included components
- Page 4..... Disassembly and Getting Started
- Page 5..... Upper Mount Assembly
- Page 6..... Final Assembly
- Page 7..... Strut Adjustment



Included ComponentsIn the box

Item #	Part #	Description	QTY
1	27569999	Strut Cartridge	2
2	90002642	Bearing Retaining Mount	2
3	70012797	Upper Mounting Plate	2
4	90002641	Strut Mount Retaing Ring	2
5	90002639	Strut Mount Rubber Isolator	2
6	70012801	O-Ring	2
7	70010943	Strut Extrusion	2
8	90002368	Thrust Bearing Adapter	2
9	70010987	Thrust Bearing	2
10	70010988	Thrust Bearing Washer	4
11	90001042	Upper Mount Bering	2
12	90000805	Bearing Snap Ring	2
13	99562003	9/16"-18 Nylok Nut	2
14	21090798	Strut Air Spring	2
15	99055000	M5 x.8 x 5mm Set Screw (Not Shown)	2
16	70008913	Locking Ring (Not Shown)	2
17	90002372	Sway Bar Link Mount	2
18	90000803	Eccentric Bolt	1
19	70010992	Strut Retaining Ring	2
20	99371042	3/8"-16 x 1" SHCS	6
21	99371004	3/8"-16 x 1 1/4" Hex Bolt	8
22	99373003	3/8" Flatwasher	16
23	99372002	3/8'-16 Nylok Nut	8
	99311029	5/16"-18 x 1" FHSC (Not Shown)	8
	90000695	Posilink Spacer (Not Shown)	2
	90002573	12mm 90 Degree PosiLink (Not Shown)	4
	31954201	1/4" 90 Degree Fitting (Not Shown)	2

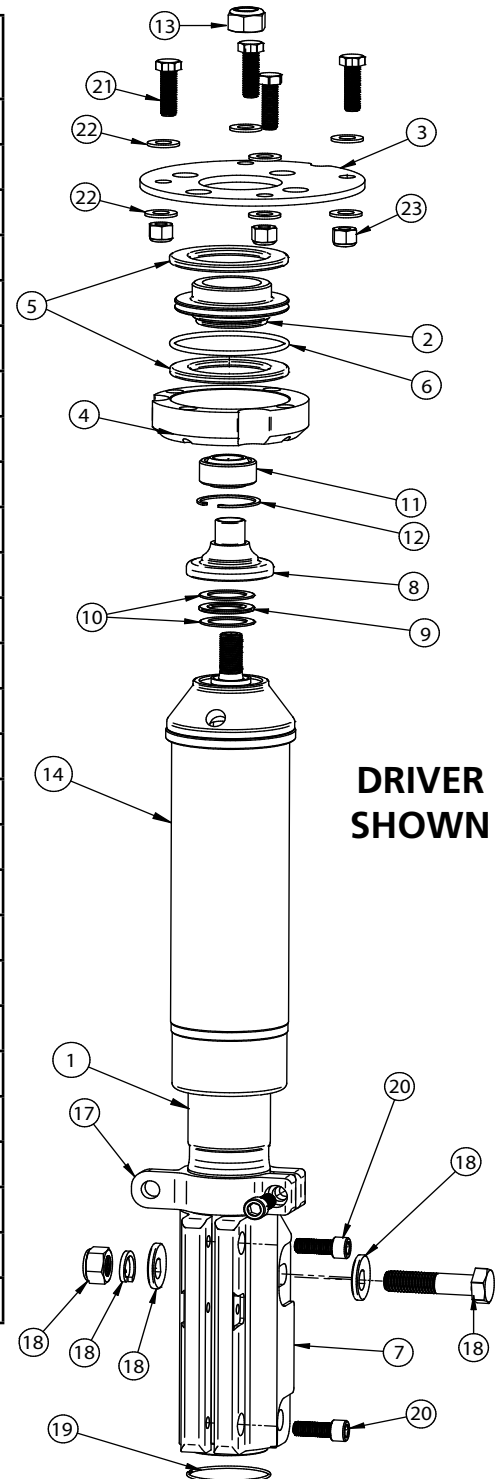



Disassembly

1. Remove the front struts by first disconnecting the ABS wire and brake line(retain hardware) from the factory strut.
2. Disconnect the swaybar linkage from the strut and swaybar this will be replaced with new linkage.
3. Support the front hub and control arm assembly and remove the (2) struts bolts(retain hardware) that attach the strut to the spindle.
4. Remove the (4) nuts holding the upper strut mount to the car body. **DO NOT REMOVE THE CENTER NUT.**
5. Remove strut assembly from the car.

Getting Started

6.

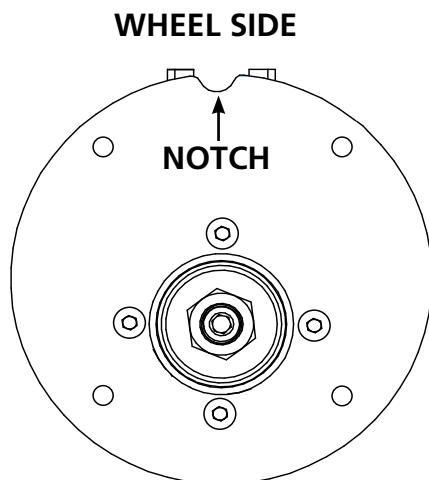

6. The upper strut mount provided in this kit has is designed to aid in tire clearance. The notch on the upper mount is positioned towards the wheel of the car.

7.

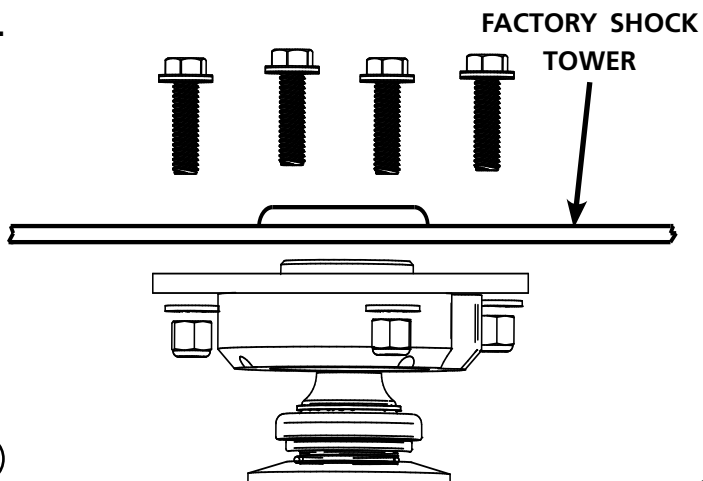

7. Bolt the upper mount into the car positioning it to the inside of the car. The camber adjustment will be done on the bottom of the strut using the supplied camber bolt. The plate gets bolted in from the bottom side of the strut tower using (4) 3/8"-16 x 1 1/4" bolts. Install a 3/8" washer on the top and bottom and secure it with (4) 3/8" 16 Nylok Nuts. Tighten all (4) down.

NOTE: The Struts are Driver and Passenger, the sway bar mount points to the rear of the car.



Upper Mount Assembly

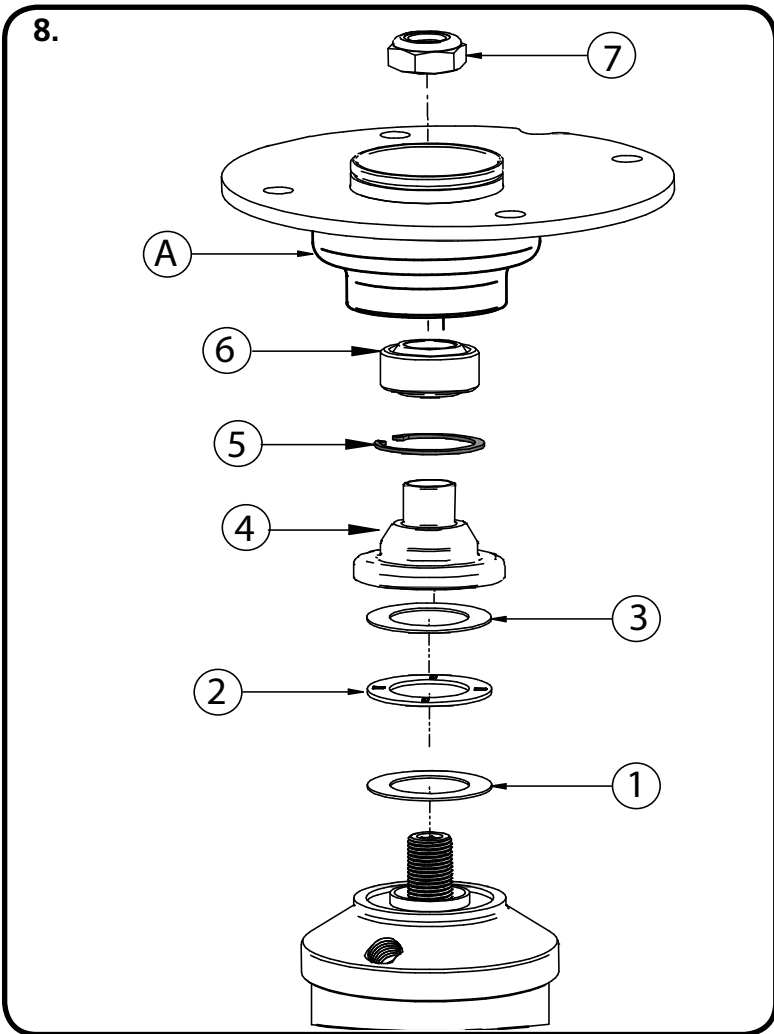

8. Install the Air fitting into the Airspring using thread tape. The Strut comes preassembled, but if for some reason you need to disassemble the strut, Figure 8 shows the assemble order. Remove the Adjuster Knob from the Strut shaft for assembly. Bolt the strut assembly into the upper mount (A), see diagram 11 for assembly order.

1. Lower Torrington Bearing Race
2. Torrington Bearing
3. Upper Torrington Bearing Race
4. Bearing Adapter (Small Diameter Up)
5. Upper Mount Bearing Snap Ring
6. Upper Mount Bearing
7. 9/16" Locknut

Assemble components and install into upper mount tightening upper nut. Reinstall upper adjustment knob

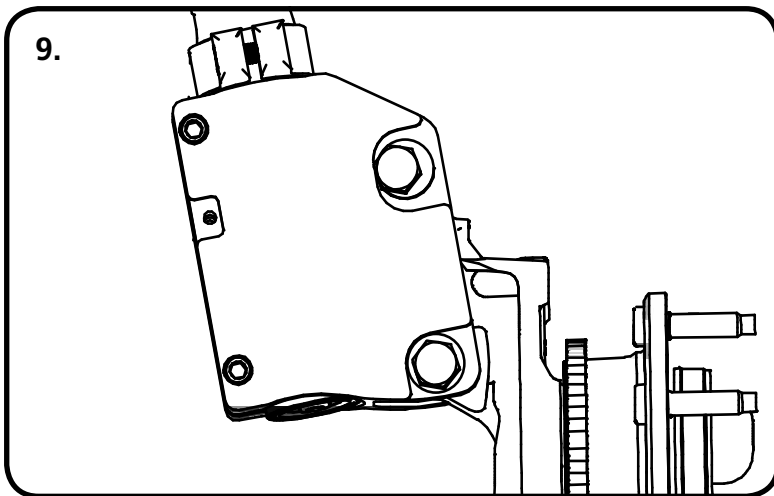

9. Slide the lower strut mount onto the spindle reusing the Factory hardware in the lower mounting hole. Insert the supplied Camber bolt into the top hole.



Assembly

10.

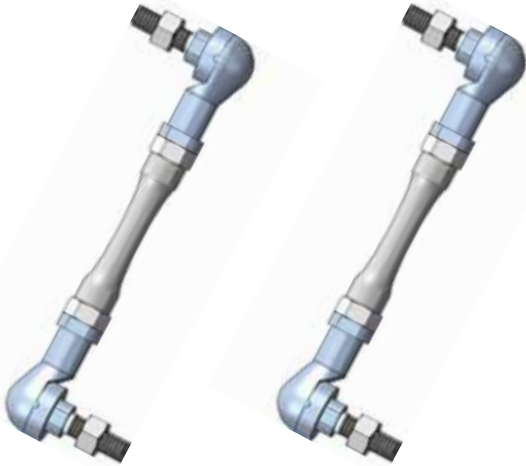

10. Attach the PosiLinks between the strut and Sway bar using the 12mm Nylok Nut. .

11.

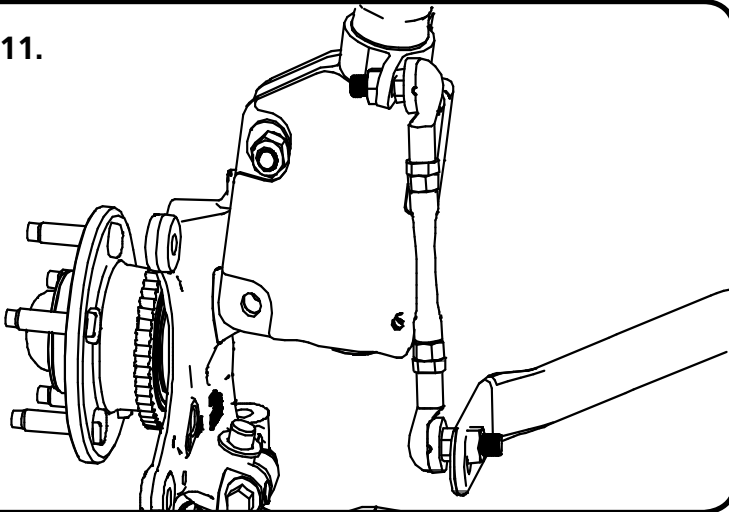

11. The Posilink mounts with the stud on the Strut pointing outward, and the stud on the Sway bar pointing in.

Note: Image is viewing the strut from rear of the vehicle.

12. Attach the brake line to the Strut using the Factory hardware.

13. Route the Airline to the Air Spring. When hooking up the Airline be sure that you can turn the steering from lock to lock with out tugging on the Airline. This situation will eventually cause the line to leak.

14. Repeat previous steps on Passenger side.



Strut Adjustment

Strut Adjustment 101- Single Adjustable

Rebound Adjustment:

How to adjust your new struts.

The rebound adjustment knob is located on the top of the Strut protruding through the upper mount.

You must first begin at the ZERO setting, then set the shock to a soft setting of 20.



-Begin with the Strut adjusted to the ZERO rebound position (full stiff). Do this by rotating the rebound adjuster knob clockwise until it stops.

-Now turn the rebound adjuster knob counter clock wise 20 clicks. This sets the shock at 20. (settings 21-24 are typically too soft for street use).

Take the vehicle for a test drive.



-If you are satisfied with the ride quality, do not do anything, you are set!

-If the ride quality is too soft increase the damping effect by rotating the rebound knob clock wise 3 clicks.

Take the vehicle for another test drive.



-If the vehicle is too soft increase the damping effect by rotating the rebound knob clock wise 3 additional clicks.

-If the vehicle is too stiff rotate the rebound adjustment knob counter clock wise 2 clicks and you are set!

Take the vehicle for another test drive and repeat the above steps until the ride quality is satisfactory.

Note:

One end of the vehicle will likely reach the desired setting before the other end. If this happens stop adjusting the satisfied end and keep adjusting the unsatisfied end until the overall ride quality is satisfactory.



Part # 12155401 - 2005-2014 Mustang HQ ShockWaves

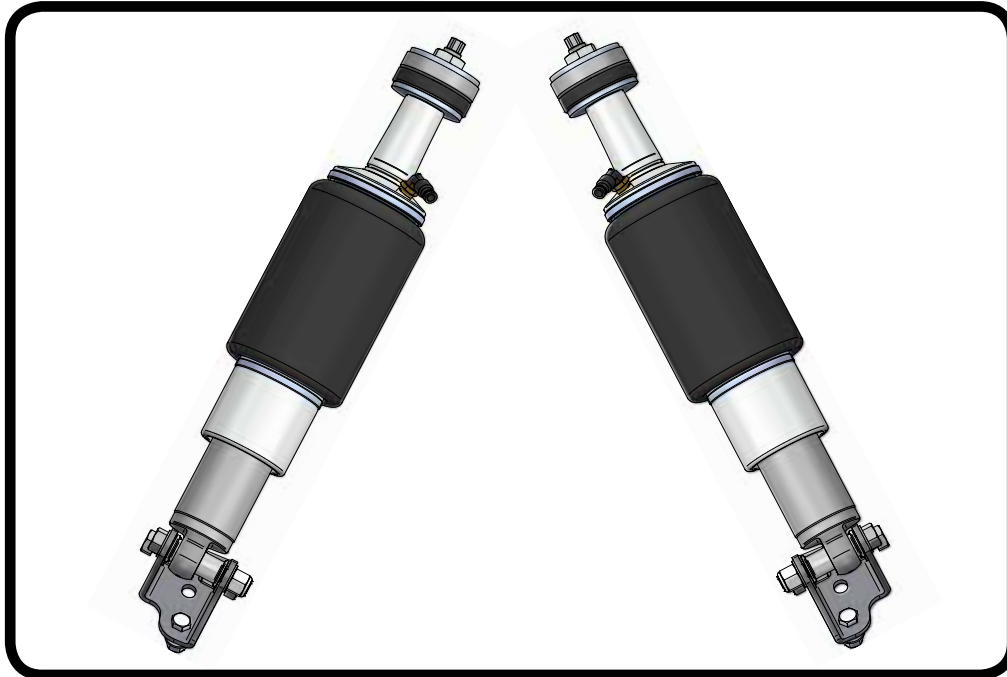

Recommended Tools

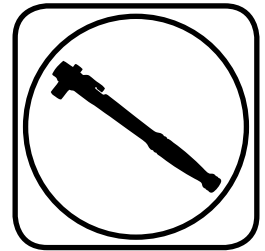

2005-2014 Mustang HQ Series Rear ShockWaves Installation Instructions

Table of contents

Page 9.....	Included components
Page 10.....	Getting Started and Disassembly
Page 11.....	ShockWave Assembly and Installation
Page 12.....	Shockwave Installation
Page 13.....	Notes and Care of Your ShockWaves
Page 14.....	Shock Adjustment



Major ComponentsIn the box

Item	Part #	Description	QTY
1	24159999	5.2" Stroke HQ Series Shock	2
2	24190799	7000 Series 4" Dia. Bellow	2
3	90009993	3.75" Stud Top	2
4	90002447	3.75" Stud Top Base	2
5	90002229	Rubber Isolator Backer Plate Upper & Lower	4
6	90001973	Lower Rubber Isolator (T shaped)	2
7	90001974	Upper Rubber Isolator	2
8	99562003	9/16-18" Nylok Nut	2
9	70008913	Air Spring Locking Ring	2
10	99055000	Locking Ring Set Screw	2
11	90002462	Inner (WIDE) Lower Shock Spacer	2
12	90002043	Outer (NARROW) Lower Shock Spacer	2
13	90002458	Driver Lower Shock Mount	1
13	90002459	Passenger Lower Shock Mount (Not Shown)	1
14	99501004	1/2"-13 x 3" Hex Bolt (Lower Shock Bolt to Mount)	2
15	99501001	1/2"-13 x 1" Hex Bolt (Lower Mount to Axle)	4
16	99502001	1/2"-13 Nylok Nut (Lower Shock & Mount Bolts)	6
17	99503001	1/2" SAE Flat Washer	8
18	99371004	3/8"-16 x 1 1/4" Hex Bolt (Lower Mount to Axle)	4
19	99372002	3/8"-16 Nylok Nut	4
20	99373003	3/8" SAE Flatwasher	4
	90001995	Bearing Snap Ring (Installed in Shock Body)	4
	90001994	5/8" ID Bearing (Installed in Shock Body)	2
21	31954201	90 Degree 1/4" Fitting	2

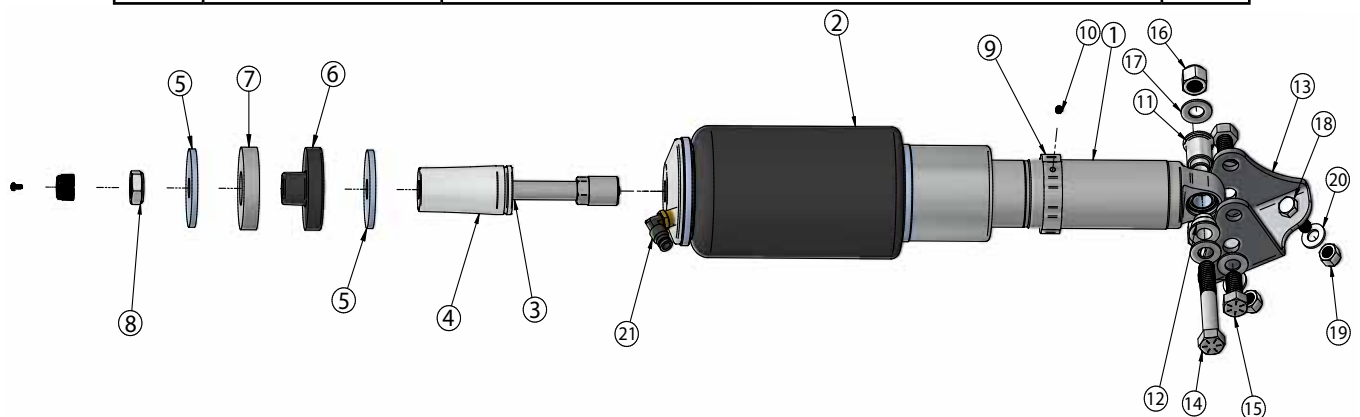



Getting Started and Disassembly

Congratulations on your purchase of the Ridetech Mustang ShockWave System. This system has been designed to give your Mustang excellent handling along with a lifetime of enjoyment. The ShockWave System provides flexibility that can not be achieved with Conventional CoilSprings.

This ShockWave System is Designed to replace the factory Shock and CoilSprings.

1. The rear OEM Shocks, Bumpstops and CoilSpring will need to be removed from the Rear of the car.
2. Raise the vehicle and support it by the frame allowing the suspension to hang freely. Be sure the rear differential will be able to swing down to get the rear springs out.
3. Place a jack under the center of the rear differential and raise it up to the point the jack is touching the rear differential. Be sure that the car is high enough that you will be able to lower the jack supporting the rear differential to remove the Coilsprings.
4. Pull the carpet on the sides of the trunk to expose the upper shock attaching nut and remove the nut.
5. Unbolt the lower shock from the shock mounting bracket.
6. Lower the jack slowly to remove the tension of the Coilspring. Pay attention to the brake line and ABS wire that you don't damage them when lowering the differential
7. With the springs loose, remove the from the car.
8. Remove the OEM bumpstop from the rear differential.
9. Remove the plastic cap from the differential in the factory coilspring location

To get Started refer to the page 4 on how to assemble the top of the ShockWave



ShockWave Assembly and installation

10.

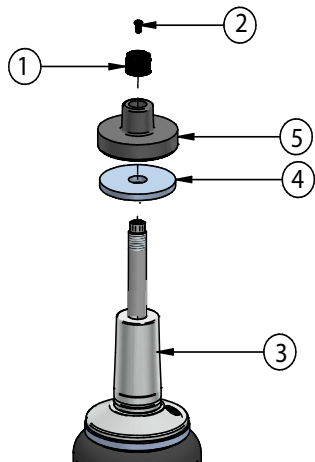

10. To Assemble the top of the Shockwave you need to:

- a. Remove Screw (2) from center of Adjustment Knob (1) and remove Adjustment Knob.
- b. Slide the Stud Top Base(3) onto the shock until it bottoms out on the stud.
- c. Slide the Lower Isolator Backer Plate (4) on to the Stud Top.
- d. Slide the Lower Rubber Isolator (5) onto the stud top.

Repeat on second Shockwave.

11.

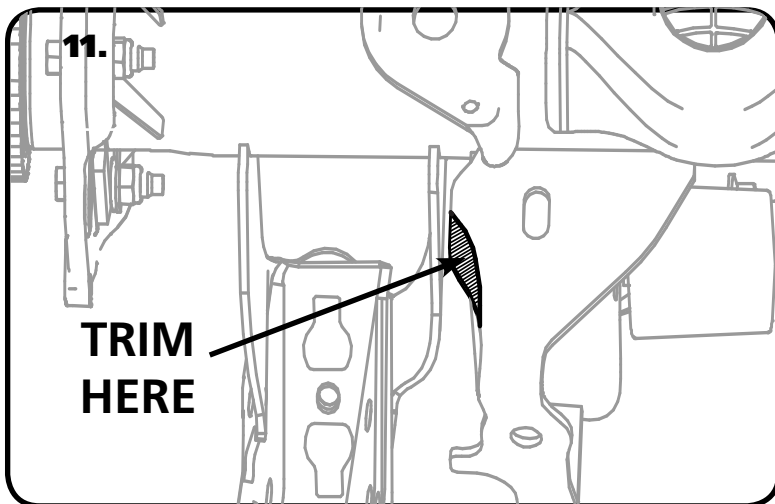

11. Before installing the ShockWaves it is necessary to do some trimming on the rear differential brackets for clearance. The corner of the panhard mount on the drivers side needs to be cleared like seen in Figure #11.

12.

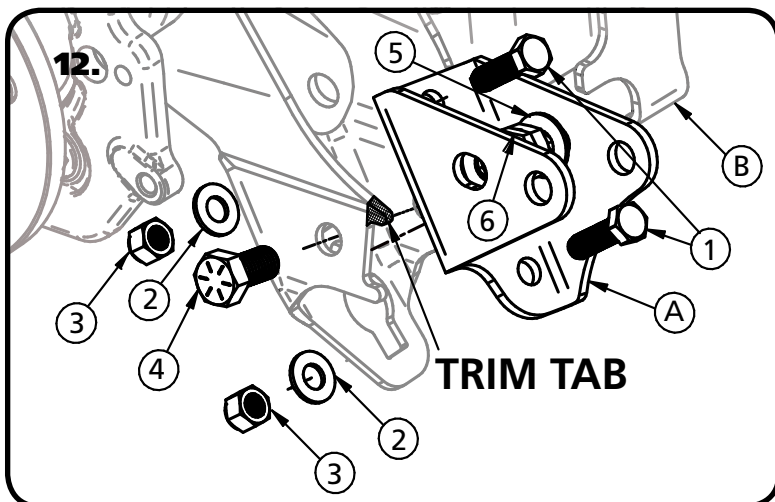

12. Trim the tab shown in the illustration. Insert the new Lower Shock Mount (A) into the OEM Shock Mount (B). Attached the Mount using 3/8" x 1 1/4" (1) Bolts in the front face of the bracket. Install a 3/8" Flat Washer (2) and 3/8" Nylok Nut (3) onto the bolts. Insert a 1/2" x 1" Hex Bolt (4) through the OEM shock mounting hole. Install a 1/2" Flat Washer (5) and 1/2" Nylok Nut (6) onto the Bolt. Tighten all Hardware.

Note: The 1/2" Bolts must be install with the Nylok Nuts in the inside of the bracket.



Shockwave Installation



13. The corner off the bracket that protrudes into the front side of the shock area needs to be trimmed off. It is necessary to trim this area for Airspring clearance. In Figure 13 the Shockwave is installed to give you reference of the area.

Failure to trim this area will cause Airspring failure.

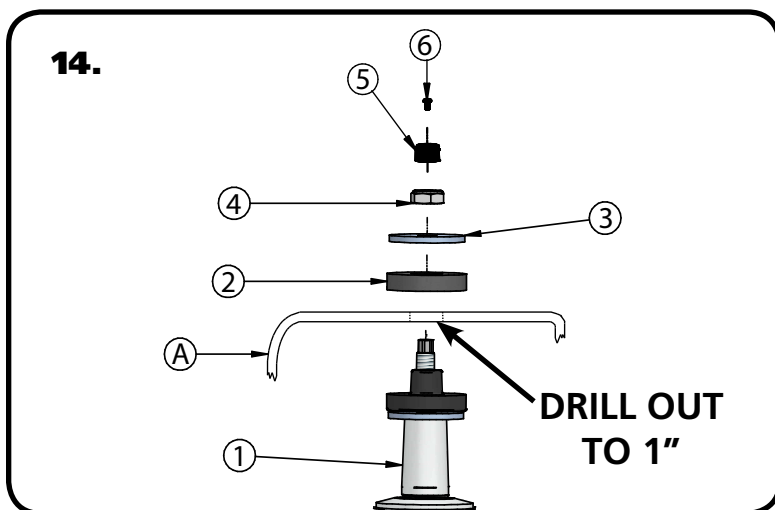

14. With the ShockWave(1) assembled, it is time to bolt them into the car. The Factory shock hole needs to be drilled out to 1", the easiest way to drill it out is with a Unibit. After drilling the hole to 1", insert the ShockWave Stud Top through the factory hole in the body. Install the Upper Rubber Isolator(2) onto the shock stud with the center hole slipping over the Lower Isolator stub sticking through the body. Next, Install the Rubber Isolator Backer Plate (3) onto the shock stud. Install the Nylok Nut(3) onto the shock stud and lightly tighten. Tighten the nut just enough to take any gap out of the bushing, its does not need to be so tight that the bushing is bulging. Reinstall the adjuster knob(5) using the screw (6) that was removed during step 10.

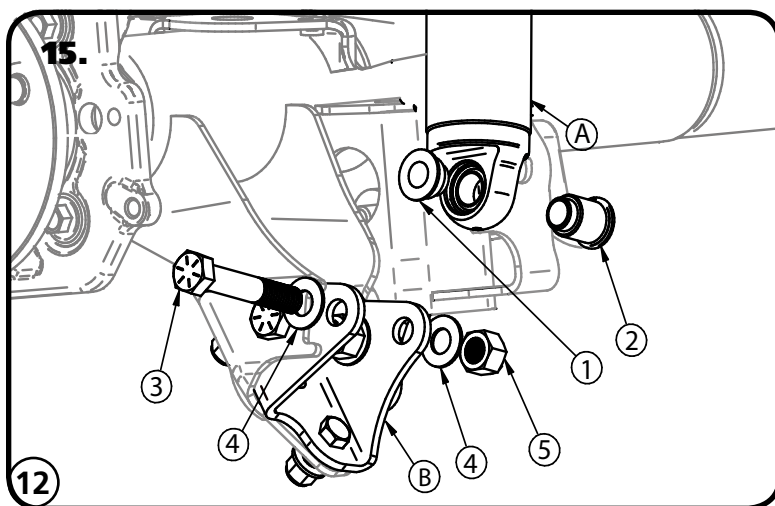

15. Install the ShockWave(A) in the OEM lower shock mount(B) using a Narrow Spacer(1) on the wheel side of the shock, and a Wide Spacer(2) on the inner side of the shock. Slide the shock into the stock mounting location. It may be necessary to use the jack and raise the differential to align the mounting holes. With the mounting holes aligned, insert a 1/2"-13 x 3" Bolt (3) and 1/2" Washer (4) through the Mount and Shock. Install a 1/2" Flat Washer (4) and 1/2"-13 Nylok Nut (5) on the Bolt and Tighten.

Repeat the steps for the other side of the car.



Installation Instructions



Notes and Care of your Shockwaves

NOTES:

You can clock the air fitting location on the ShockWave by turning the AirSpring assembly of the shock.

The threads on the fittings need to have thread sealant applied to seal properly.

When cutting the airline, use a razor blade. The cut needs to be a clean cut and square for the airline to seal properly.

The Locking ring on the shock is **NOT** adjustable. These rings are set at the factory to optimize the Air-Spring stroke with the shock stroke.

The care and feeding of your new ShockWaves

1. Although the ShockWave has an internal bumpstop, **DO NOT DRIVE THE VEHICLE DEFLATED RESTING ON THIS BUMPSTOP. DAMAGE WILL RESULT.** The internal bumpstop will be damaged, the shock bushings will be damaged, and the vehicle shock mounting points may be damaged to the point of failure. This is a non warrantable situation.
2. Do not drive the vehicle overinflated or "topped out". Over a period of time the shock valving will be damaged, possibly to the point of failure. This is a non warrantable situation! If you need to raise your vehicle higher than the ShockWave allows, you will need a longer unit.
3. The ShockWave is designed to give a great ride quality and to raise and lower the vehicle. **IT IS NOT MADE TO HOP OR JUMP!** If you want to hop or jump, hydraulics are a better choice. This abuse will result in bent piston rods, broken shock mounts, and destroyed bushings. This is a non warrantable situation.
4. Do not let the ShockWave bellows rub on anything. Failure will result. This is a non warrantable situation.
5. The ShockWave product has been field tested on numerous vehicles as well as subjected to many different stress tests to ensure that there are no leakage or durability problems. Failures have been nearly nonexistent unless abused as described above. If the Shockwave units are installed properly and are not abused, they will last many, many years. ShockWave units that are returned with broken mounts, bent piston rods, destroyed bumpstops or bushings, or abrasions on the bellows will not be warrantied.



Shock Adjustment

Shock adjustment 101- Single Adjustable

Rebound Adjustment:

How to adjust your new shocks.

The rebound adjustment knob is located on the top of the shock absorber protruding from the eyelet.

You must first begin at the ZERO rebound setting, then set the shock to a soft setting of 20.



-Begin with the shocks adjusted to the ZERO rebound position (full stiff). Do this by rotating the rebound adjuster knob clockwise until it stops.



-Now turn the rebound adjuster knob counter clock wise 20 clicks. This sets the shock at 20. (settings 21-24 are typically too soft for street use).

Take the vehicle for a test drive.



-if you are satisfied with the ride quality, do not do anything, you are set!

-if the ride quality is too soft increase the damping effect by rotating the rebound knob clock wise 3 clicks. **CONTINUE ON NEXT PAGE.**

Take the vehicle for another test drive.



-if the vehicle is too soft increase the damping effect by rotating the rebound knob clock wise 3 additional clicks.



-If the vehicle is too stiff rotate the rebound adjustment knob counter clock wise 2 clicks and you are set!

Take the vehicle for another test drive and repeat the above steps until the ride quality is satisfactory.

Note:

One end of the vehicle will likely reach the desired setting before the other end. If this happens stop adjusting the satisfied end and keep adjusting the unsatisfied end until the overall ride quality is satisfactory.